

SWATCH GROUP
ANNUAL REPORT
2014



CONTENTS

Message from the Chair	2
Operational Organization	4
Organization and Distribution in the World	5
Organs of Swatch Group	6
Board of Directors	6
Executive Group Management Board	8
Extended Group Management Board	9
Development of Swatch Group	10
Art & Philanthropy	11
Big Brands	15
Watches and Jewelry	16–80
Retailing and Presence	81–86
Production	87
Electronic Systems	97
Corporate, Belenos	103
Swatch Group in the World	111
Governance	137
Environmental Policy	138
Social Policy	140
Corporate Governance	142
Financial Statements 2014	155
Consolidated Financial Statements	156
Financial Statements of the Holding	206
Compensation Report 2014	219



Swatch Group's Annual Report and Compensation Report are published in French, German and English. Pages 1 to 141 are originally published in French and pages 142 to 218, as well as the Compensation Report, in German. These original versions are binding.

MESSAGE FROM THE CHAIR

**Dear Madam, Dear Sir,
Dear Fellow Shareholders,**

“Construction site”... a term often used to identify an area where there are still problems to solve. I would like to use it in the way Swatch Group sees it: building, creating something new, developing, improving, taking the bull by the horns. Glamour, luxury and red carpets are only possible with the benefit of a sound basis – a firm foundation that is the fundamental prerequisite for any construction. Within Swatch Group, here in Switzerland, we have many construction projects under way. And we are proud of them!

Every day, hundreds of feet in rubber boots trudge through the mud at these construction sites. Hundreds and hundreds of hands tackle tasks, mix the concrete, operate the diggers and the cranes, mill, sand, do carpentry, plastering, painting... or they build scaffolding and sanitary facilities, lay electric cables, install machines. This is about the hundreds of jobs that Swatch Group – along with the 770 additional positions that the company created internally in 2014 – supports and develops. Here, in Switzerland, because it is here that we produce, here that we build factories and here that we renovate, modernize and develop them. Because it is also here, in Switzerland, that we want to be established and to manufacture in the future. For you, for us, for industry, for the region and through this, for Switzerland. Because to us, the idea of “outsourcing abroad” is utter nonsense.

You may remember that in 2013, we completed the construction of big production sites in Grenchen (SO), in Villeret (BE) and in Boncourt (JU). Last year, we built in Saint-Imier (BE), in Lengnau (BE), in Le Locle (NE), in Fontaines (NE), in Col-des-Roches (Le Locle), in Geneveys-sur-Coffrane (NE) and finally in Biel/Bienne (BE) as well.

Now, if your fingers are twitching and you are sorely tempted to build a factory yourself... this also isn't too big a deal for Swatch Group. We are the masters of miniaturization – so we have carefully reduced the construction elements to a scale of 1 to... x. Well, see for yourself and build your own Swatch Group factory in Switzerland! You won't even need rubber boots to do it.

Nevertheless, maintaining production in Switzerland and remaining profitable also means staying ahead of the game in terms of quality and development. This cannot happen without excellent products and cutting-edge skills. For this reason, in addition to infrastructure, we also invest in research; we deal with high-performance electronic chips, completely innovative batteries, touch screens, solar panels, anti-magnetic and other

materials; we examine, we explore, we review... and, of course, we also invent. In 2014, we registered a new patent on average every two days.

Speaking of the latest skills, we have also always invested in training. Swatch Group employees have bright prospects here: we train several hundred apprentices and then offer them stable employment; and young people as well as experienced professionals continue to learn or specialize in the course of their careers. With Blancpain and Jaquet Droz leading the way, we also make an enormous investment in the preservation of ancient crafts that are essential to the watchmaking industry.

That's how we strengthen industry in our country. That's how we shape a future for our current and future employees. Goethe said it perfectly: “Success has three letters: ACT*.” And “act” means getting your feet muddy, even when it's raining, pulling on your boots and rolling up your sleeves. One last thing concerning training: in November 2014, the Hans Huber Foundation paid tribute to our way of “acting” in the field of professional training with a national recognition award. During the award ceremony, Swatch Group was referred to as the “most important training company in the watchmaking industry” and as such, “an example to follow”. The professional training within Swatch Group was judged practical, appropriate, creative and free from any prejudice. We are delighted with this award.

With regard to our results in 2014: once again this year, we achieved a record turnover – which is in itself an achievement in the current difficult climate. Gross sales reached 9.219 billion Swiss francs, a 4.6% increase compared to 2013. Something of a shadow was cast over this record figure in terms of net income – which, for the first time in a very long while, was below the record result of the previous year; it was 26.6% lower than in 2013. And yet, recording a net income of 1.416 billion Swiss francs (and a return on net sales of 16.3% of the net sales of 8.709 billion Swiss francs), along with an operating profit of 1.752 billion Swiss francs, meaning an operating margin of 20.1%, is remarkable for an industrial company in the current difficult economic environment. In the same way, we remain as robust as in the past in terms of equity: 10.674 billion Swiss francs, corresponding to an 83.7% equity ratio – how many companies do you know with an equity ratio like that?

Given the good results in 2014 and the prospects that we consider positive for 2015, at the General Assembly on May 28th 2015, the Board of Directors of Swatch Group will propose the same

* Original quote by Goethe: “Erfolg hat drei Buchstaben: TUN”



dividend as those for the record year in 2013: CHF 7.50 per bearer share and CHF 1.50 per registered share.

Among the striking achievements in 2014, and in addition to our many construction projects, at the end of November, we acquired the Peterhof building on the Bahnhofstrasse in Zurich. This is one of the most emblematic buildings in the famous shopping precinct. With its distinctive neo-Gothic style, this historic edifice is one of the most beautiful in Zurich and remains in Swiss hands thanks to Swatch Group.

In terms of the year's other Swatch Group highlights, I would like to mention the December development of a new quality certificate by Omega, in partnership with the Federal Office of Metrology (METAS). To obtain a quality certificate, a watch must meet certain precision criteria, including when it is exposed to a magnetic field above 15000 gauss. To date, only Omega's Master Co-Axial can do that... With Harry Winston, we have renovated or inaugurated several superb Salons in important cities. And we have also been active in sporting terms – we were present at the Sochi Olympic Winter Games with Omega.

Taking account not only of the business aspects but also being involved in a wider context is a constant concern for me, for us. With this in mind, our watchmaking brands consistently focus on environmental protection. Notably, Blancpain is involved in the preservation of the seabed and has strengthened its commitment to the oceans with the launch of its new Blancpain Ocean Commitment campaign in Cap d'Antibes. Omega for its part has supported projects in Indonesia for the protection of mangroves and seagrasses, which are key to biodiversity.

The art and intangible values that make our world a better place to live are also not overlooked. With their involvement, Breguet and Glashütte Original have a fairly classic approach. This has resulted in our presence with Breguet in Paris, for example, where the brand emphasized its passion for cultural heritage and where in December it reinforced its partnership with the prestigious Louvre Museum.

Swatch supports art in its most contemporary aspects: thus in autumn, we yodeled on the Bund in Shanghai – yes, I promise you! But above all, every year, about 50 contemporary artists have an opportunity to develop their art and consider things from a different point of view at the Swatch Art Peace Hotel. There would still be so many more things to say about the Swatch Group companies. We invite you to discover them in the 2014 Annual Report!

To conclude, I would briefly like to address a subject that I do not usually talk about in public. The saying "do a good job and tell the world" is not my style at all. However, I would particularly like to share this with you today. Perhaps because discussions in

the past few months have been exclusively focused on subjects such as currencies, the drop in profits, the share price or, simply expressed, other even more complex subjects.

We are aware of our social responsibility, not only with regard to jobs in Switzerland. Every year, Swatch Group supports many people in need: children in the Gaza strip; those in the Philippines who have lost everything; children whose eyes have been saved thanks to Orbis International and Omega; countless people with mental health problems who receive support thanks to Harry Winston. Through our brands, we also help fund various research programs in the fight against disease, especially in the field of pediatrics. We provide support to a number of organizations designed to help children. This includes children who grow up in difficult circumstances, sick children, child victims of violence and children who live in deprived economic conditions. Through these organizations, children in countries such as Brazil, the United States, Japan and China secure the chance of a better future. Longines, Harry Winston, Swatch and Mido are very involved in these projects.

This fills me with gratitude, dear Shareholders. I am grateful that we, and all of you with us, are also in a position to give a little something to the needy and to victims of circumstance.

I would particularly like to thank the Board of Directors, the Executive Group Management Board and the Extended Group Management Board, all our 35500 employees in Switzerland and across the world, who every day, make Swatch Group a company which acts, which lives and which gives the term "construction site" a magical meaning. And finally, my thanks to all of you, dear Shareholders, for your loyalty and support.

Thank you!

Nayla Hayek
Chair of the Swatch Group Board of Directors

SWATCH GROUP OPERATIONAL ORGANIZATION

as at December 31, 2014

SWATCH GROUP BRANDS AND COMPANIES

WATCHES	RETAILING	PRODUCTION	ELECTRONIC SYSTEMS	CORPORATE
<p>Prestige and Luxury Range</p> <p>Breguet Harry Winston Blancpain Glashütte Original Jaquet Droz Léon Hatot Omega</p> <p>High Range</p> <p>Longines Rado Union Glashütte</p> <p>Middle Range</p> <p>Tissot Balmain Certina Mido Hamilton Calvin Klein watches + jewelry</p> <p>Basic Range</p> <p>Swatch Flik Flak</p>	<p>Tourbillon Hour Passion</p>	<p>Watches</p> <p>ETA Meco François Golay Nivarox-FAR Comadur Rubattel et Weyermann MOM Le Prélet Universo Manufacture Ruedin Lascor Simon Et Membrez Novi Swatch Group Assembly</p> <p>Jewelry</p> <p>Dress Your Body (DYB)</p>	<p>EM Microelectronic Renata Micro Crystal Swiss Timing and ST-Sportservice</p>	<p>Swatch Group Research and Development (Asulab, Moebius, CDNP) ICB Ingénieurs Conseils en Brevets Swatch Group Quality Management Swatch Group Services (European Distribution Center, Swatch Group Logistics, Swatch Group IT Services, Swatch Group Corporate Customer Service, Real Estate Development) Swatch Group Immeubles</p>

SWATCH GROUP ORGANIZATION AND DISTRIBUTION IN THE WORLD

as at December 31, 2014

SWATCH GROUP SUBSIDIARIES

EUROPE	AMERICAS	OCEANIA	FAR EAST	MIDDLE EAST	AFRICA
Austria	Brazil	Australia	China	United Arab Emirates	South Africa
Belgium	Canada		Hong Kong		
Denmark	Caribbean		India		
Finland	Mexico		Indonesia		
France	USA		Japan		
Germany			Macau		
Greece			Malaysia		
Italy			Singapore		
Luxemburg			South Korea		
The Netherlands			Taiwan		
Norway			Thailand		
Poland					
Russia					
Spain					
Sweden					
Switzerland					
Turkey					
United Kingdom and Ireland					

In countries where Swatch Group has no actual distribution subsidiary, the company is represented by local distributors.

SWATCH GROUP BOARD OF DIRECTORS

as at March 1, 2015



Nayla Hayek

Chair of the Board of Directors

Company Secretary

Jennifer Meyer-Kluge

Auditors

PricewaterhouseCoopers
St. Jakobs-Strasse 25
CH-4052 Basel

Administrative Headquarters

Seevorstadt 6
CH-2501 Biel/Bienne
Phone: +41 32 343 68 11
Fax: +41 32 343 69 11
E-mail: www.swatchgroup.com/contactus
Internet: www.swatchgroup.com

Registered Offices

Faubourg de l'Hôpital 3
CH-2000 Neuchâtel



Ernst Tanner
Vice-Chairman



Nick Hayek



Prof. Dr. h.c. Claude Nicollier



Dr. Jean-Pierre Roth

The function descriptions and responsibilities of the Board of Directors members at December 31, 2014 are outlined in the Corporate Governance chapter on pages 145 and 146 of the present Annual Report.

SWATCH GROUP EXECUTIVE GROUP MANAGEMENT BOARD

as at March 1, 2015



Nick Hayek

President of the Group Management Board



Florence Ollivier-Lamarque



Pierre-André Bühler



Dr. Mougahed Darwish

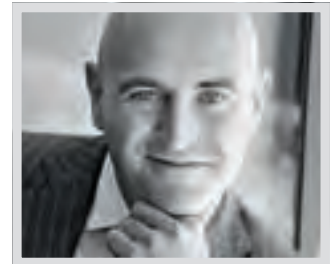

Marc A. Hayek



Dr. Thierry Kenel



Dr. Hanspeter Rentsch



François Thiébaud

SWATCH GROUP EXTENDED GROUP MANAGEMENT BOARD

as at March 1, 2015



Raynald Aeschlimann



Matthias Breschan



Jean-Claude Eggen



Yann Gamard



Hans Rudolf Gottier



Walter von Känel



Thomas Meier



Calogero Polizzi



Kevin Rollenhagen



Dr. Peter Steiger



Stephen Urquhart

The function descriptions and responsibilities of the members of the Executive Group Management Board and of the Extended Group Management Board at December 31, 2014 are outlined in the Corporate Governance chapter on pages 147 to 150 of the present Annual Report.

DEVELOPMENT OF SWATCH GROUP

Swatch Group consolidated		Swiss GAAP FER			IFRS		
		2014	2013	2012	2012	2011	2010
Gross sales	CHF million	9 219	8 817	8 143	8 143	7 143	6 440
– Change from previous year	%	4.6	8.3	14.0	14.0	10.9	18.8
Net sales	CHF million	8 709	8 456	7 796	7 796	6 764	6 108
– Change from previous year	%	3.0	8.5	15.3	15.3	10.7	18.8
Operating profit	CHF million	1 752	2 314	1 978	1 984	1 614	1 436
– As a % of net sales	%	20.1	27.4	25.4	25.4	23.9	23.5
Net income	CHF million	1 416	1 928	1 604	1 608	1 276	1 080
– As a % of net sales	%	16.3	22.8	20.6	20.6	18.9	17.7
– Change from previous year	%	–26.6	20.2	25.7	26.0	18.1	41.5
Cash flow from operating activities	CHF million	1 848	1 309	999	999	705	1 353
– As a % of net sales	%	21.2	15.5	12.8	12.8	10.4	22.2
Equity	CHF million	10 674	9 574	8 573	9 344	8 071	7 101
– As a % of total assets	%	83.7	82.3	82.2	83.3	82.3	82.4
Total assets	CHF million	12 747	11 639	10 430	11 222	9 805	8 614
Personnel as at 31.12.	Employees	35 623	33 590	29 788	29 788	28 028	25 197
Annual average	Employees	34 492	31 114	28 942	28 942	26 777	24 240
Personnel expense	CHF million	2 343	2 144	1 988	1 982	1 818	1 634

The Swatch Group Ltd		2014	2013	2012	2011	2010
Dividend income	CHF million	1 071	1 565	1 065	739	564
Net income	CHF million	1 100	1 880	1 085	756	581
Investments	CHF million	3 113	3 056	2 493	2 137	2 091
Share capital	CHF million	125	125	125	125	125
Equity	CHF million	5 928	5 215	3 926	3 151	2 666
– As a % of total assets	%	96.8	96.3	95.0	93.3	91.9
Total assets	CHF million	6 127	5 415	4 131	3 377	2 901
Dividend ¹⁾	CHF million	417.4 ²⁾	407.4	366.3	310.3	270.2
– As a % of share capital	%	333.9	325.9	293.0	248.2	216.2

¹⁾ No dividend paid on own shares held by the Group.²⁾ Proposal by the Board of Directors to the Annual General Meeting.

ART & PHILANTHROPY





ART & PHILANTHROPY

Keenly aware of its social responsibility, Swatch Group is committed, directly or through its brands, to various causes all over the world.

ADDRESSING EMERGENCIES

In the humanitarian field, support was given to Terre des Hommes for its action in favor of children in the Gaza strip, the first civilian victims of the regional conflict; the operation involves the distribution of drinking water, food and emergency supplies to 1600 families, or 11 200 people, affected by the war. Natural disasters also bring desolation and in a gesture comparable to the one made following the tsunami in the Indian Ocean in 2004, Swatch Group offered an important contribution to a Doctors without Borders initiative carried out in the Philippines following Typhoon Haiyan, which destroyed many health facilities; the intervention involves mobile clinics supplying survivors, who are often displaced, with basic medical care and mental health first aid.

RESPONDING TO HUMAN SUFFERING

Other activities in the medical sector were undertaken by the Swatch Group brands: Omega continued to work with Orbis International, supporting its Flying Eye Hospital in its battle against avoidable and curable blindness. Harry Winston continued to support institutions treating physical and psychological suffering caused by illness. The brand also renewed its commitment to the pediatrics sector, notably with the creation of an important grant program designed to finance work conducted by medical researchers.

PROVIDING A BETTER FUTURE

While the plight of people suffering from ill health is an area of concern, disadvantaged children remain the focus of attention for Swatch Group brands. Harry Winston is committed to a number of different educational causes through its Harry Winston Brilliant Futures™ charity program. Longines renewed its support to the Children of Tomorrow foundation, which is concerned with rebuilding the psychological integrity of children scarred by violence, as well as the Andre Agassi Foundation for Education which offers free coaching to troubled young people. Because proper nutrition is beneficial to education, the brand also supported JustWorld International in the context of an initiative which allowed 45000 meals to be served to 3500 children in Cambodia, Honduras, Guatemala and Columbia. In addition, Longines committed itself to supporting the Rainbow Centre – Margaret Drive School program in Singapore, targeting young people with special education needs. Swatch also focused on

providing a socio-educational response to poverty by supporting the Gol de Letra Foundation with the Entusiasmo action conducted with children living in a high-risk environment in Brazil during the most recent football World Cup. In addition, the brand supported the Proyecto Sofía Mulanovich in Peru, which offers special teaching combining sport and educational content. Mido gave support to young Chinese, contributing to the building of a library in a school in an isolated rural area in Tibet.

SUPPORTING THE NEXT GENERATION

Given that youth represents the future, Rado offered young designers a platform on which they can publish their work in the area of community design, rewarding two projects. One of these is in the form of molds enabling the creation of dolls for underprivileged children, a game that contributes to improving literacy. The other concerns a compact mobile office made of recycled materials, offering the possibility of studying under any conditions at school or at home.

DEVELOPING TRAINING AND JOBS

Training is also at the heart of a major socio-economic action, whose first beneficiaries are the more than 500 apprentices hired in 2014 in the different Swatch Group entities to complete their professional training. This investment was rewarded with a prize from the Hans Huber Foundation, which praised Swatch Group for being the most important training company in the watchmaking industry and which named it as an example to follow. This approach to skills development contributes to the building of the next generation to take over and, by maintaining a strong industrial fabric in the regions in which Swatch Group companies are established, reflects the determination to develop and preserve jobs.

PRESERVING THE ENVIRONMENT

Environmental protection is just as important as preserving socio-economic conditions. Part of the range of concerns that always drove the founder of Swatch Group, Nicolas G. Hayek, many activities took place in this sector. Blancpain continued its commitment to the preservation of the underwater world: the Blancpain Ocean Commitment unifies a number of operations, and finances scientific expeditions for underwater research and exploration. Partner to the Historical Diving Society Hans Hass Award, which rewards pioneering initiatives in this regard, the

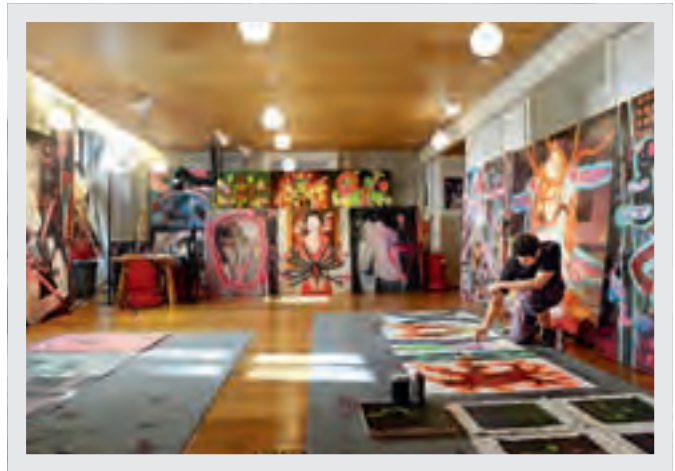
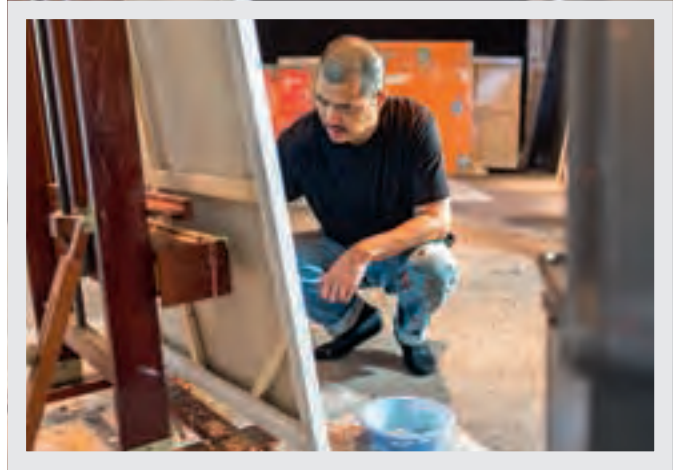

brand has become one of the key sponsors of the World Oceans Summit while coordinating other activities in order to sensitize public opinion to the challenges linked to the preservation of the oceans. Taking part in the Solar Impulse adventure, including the project to fly around the world in an airplane exclusively fuelled by solar energy and thereby demonstrating the potential of this source of renewable energy, Omega is also involved with the preservation of ecosystems through support for the GoodPlanet Foundation. The brand's contribution notably goes to the Time for the Planet program for the restoration of mangroves in Indonesia, an environment which is home to one of the greatest concentrations of bio-diversity on the planet. Swatch and the athletes on the Swatch Proteam pledged their support to the IAMECO (I am Eco) Warrior action. Through a community of opinion leaders, this movement encourages young people to think of creative ways of shaping a more sustainable future. By partnering The Water Tank Project in New York, the brand also conducted another environmental activity, transforming water reservoirs in New York into works of art, emphasizing the importance of preserving the most essential natural resource.

TRANSMITTING A HERITAGE

While this determination to preserve the environment for future generations drives Swatch Group and its brands, the concern with bequeathing a heritage is no less important. As part of this mindset, Blancpain and Jaquet Droz reinvested in artistic crafts that are transmitted from artisan to artisan; engraving with small chisel and through a microscope, the damascene work, enamel painting and the art of *paillonnage* are just some of the techniques elevated to the status of art that the two brand have contributed to reviving and perpetuating. Moving from preserving ancestral skills to preserving a historic and cultural heritage, Breguet was very committed as a sponsor to the renovation of the Louis XIV

to Louis XVI Rooms at the Louvre Museum. With the same concern for the preservation of historic and cultural treasures, Swatch decided to contribute to restoration work undertaken at the Abbaye de Saint-Maurice (VS).

ART FOR ART'S SAKE

Swatch Group is committed to making a contribution to artistic expression through its brands. A number of initiatives have been undertaken to achieve this determination, from raising the profile of technicians of the seventh art with Hamilton to supporting classical music virtuosi with Breguet and Glashütte Original. But the most emblematic action on the art scene is unquestionably that undertaken by Swatch at the Swatch Peace Art Hotel. Incorporating a residence for artists, this historic Shanghai building hosts talented individuals from all over the world who stay there and work freely in an environment conducive to creative expression. Because art is also what makes life so vibrant...

These activities, both artistic and philanthropic, are the reflection of the concerns that drive Swatch Group and its brands. Some are not mentioned here, although they are also developing initiatives in this domain.

BIG BRANDS

WATCHES
AND JEWELRY
RETAILING
AND PRESENCE



swatch[®]+

www.swatch.com



SWEETNESS & LIGHT

TRENDS

Nowadays the world is definitely in need of some lightness. Thus, in 2014, Swatch developed some of its collections along playful and ironic themes that perfectly represent the brand's DNA – Lightness, Transparency, Colors – and of course, Joie de Vivre! The Pastry Chefs line was a huge success in spring, with Swatch *aficionados* around the world becoming cake designers and sweets-makers, for a real “Made in Sweet-zerland” moment! In the fall, a wave of metallic colors and textures with a million-dollar look, juxtaposed with the British-ness of a world in checkered patterns, brought style and light-hearted sophistication to Swatch shelves.

To counterbalance this need for lightness, substance is of the essence – and democratic price positioning is definitely a plus: Swatch SISTEM51 was highlighted worldwide as the foundation of the new Swatch revolution, and the four styles of the collection sat on the “top ten” list for many months – meaningful recognition of the fact that Swiss Made and innovation can walk hand in hand and make a difference in a very smart way indeed. Lightness, substance...and beauty? The heart of Swatch has always beat at the pace of artists: 2014 was a year rich in collaborations with the arts, and the Alexander Gorlizki Art Special was a definite highlight with its colorful, refined and exotic patterns and the rich storytelling behind it. It can truly be said that design and beauty count, but a Swatch storytelling moment counts just as much!

CREATION

SPECIALS

2014 began with a celebration of Chinese New Year and the introduction of the Swatch Special, Year of the Horse. The horses that are ubiquitous in Chinese art inspired the design of the watch, which recalls traditional Chinese drawing and calligraphy with its inky black brush strokes and watery grays on a white background. Its dynamic impressions of horses in motion are a fitting tribute to the Year of the Horse. 2014 saw a new Swatch Art Special as well: Alexander Gorlizki, a virtuoso creator of intricate miniatures and visionary abstraction, created a surreal and playful mix of East and West in Sliding Doors, inspired by classical Indian ornamental screen carvings.

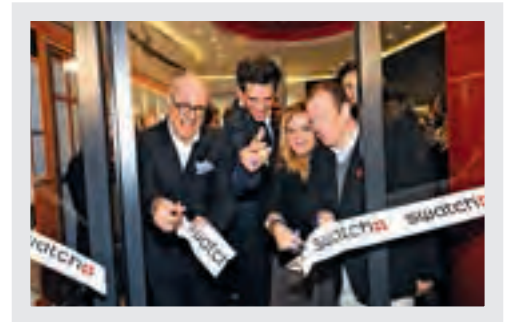



RETAIL

Thanks to the remarkable expansion in retail throughout the world, 2014 was an extraordinary year for the brand, which opened new flagship and megastores on the most prominent streets in the world, and a series of pop-up stores in support of SISTEM51. All had the same look and feel, featuring the single blue screw and the design aspects of the watch.

ASIA

With SISTEM51, Swatch opened up an exciting new page for the watch industry. The turned-the-world-upside-down collection was presented at Basel in 2013 and the voyage of discovery continued throughout Asia in 2014 in China, Hong Kong, Japan, South Korea, Philippines, Taiwan, Macau, Singapore and Malaysia. Several pop-up stores were opened in the hearts of the metropolises in all of these, which generated excellent results in terms of sales performance and an enormous boost in terms of sales uplift and units sold. Crowds of media, guests and Swatch fans joined the celebration of the pop-up stores' grand openings to witness the new watchmaking marvel.

2014 was certainly a year to be remembered. The front of SISTEM51 told us the time and its back told us the story, a true innovation in the watch industry!

MIDDLE EAST

Swatch reinforced its position thanks to steady focus on a larger retail distribution network throughout the Middle East. Regional training continued to be an essential activity and contributed to higher sales while increasing the sense of belonging to the brand. Tremendous marketing activities for collections such as Pastry Chefs and Big Classic along with the opening of SISTEM51 pop-up stores in Dubai, Jeddah and Riyadh generated excellent results.

EUROPE

Swatch's store network proved to be a great stage for the introduction of emblematic collections. The Pastry Chefs collection launched in January provoked irresistible emotions in the eyes of consumers, providing European markets with best-sellers such as Caramellissima, a candy watch that performed brilliantly for several months to follow. The new Big Classic product line proudly established a stable trend throughout the entire year, promising continued class and style in 2015. With the opening of further pop-up stores in select European markets, the success story of SISTEM51 accompanied encouraging positive market growth.

AMERICAS

The beauty of SISTEM51 and other collections was highlighted in Swatch stores thanks to special events that attracted a national and international audience. Stores were also very active in offering events to Swatch collectors, notably at New York-New York in Las Vegas. Other impressive gatherings took place at the Times Square store in New York City as well as in Mexico City and Latin American countries. Another very important milestone was the opening of the megastore on Saint Catherine Street in Montreal.

SALES

2014 saw pop-up stores open worldwide in support of the ongoing roll-out of the innovative SISTEM51.

MILANO – VIA MONTENAPOLEONE

British pop singer Mika opened Swatch's new flagship store on via Montenapoleone, an international crossroad for shopping in Milan. The store combines the best qualities of Switzerland and Milan in an original interpretation of contemporary retail design, underlining Swatch's fashionable spirit, its energy and its ability to go beyond the confines of the ordinary.

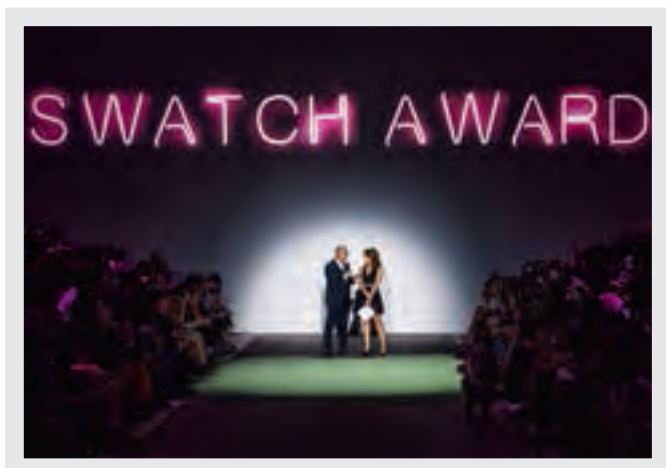

HAMBURG – JUNGFERNSTIEG

Swatch hoisted its sails with a new flagship store in the beautiful harbor city of Hamburg, prominently located on the legendary Jungfernstieg shopping boulevard. Housed in a historic building, the new flagship store fuses traditional Swiss values with Hamburg's coolness and urbanity; it opened with a remarkable art and music performance by artist Mimi Müller-Westernhagen.

SWATCH AND SWATCH-ART HAPPENING SPACE – MAKATI CITY

An impressive two-story space saw the light at Makati City as a milestone to celebrate the 25th anniversary of Swatch in the Philippines. The Swatch+Swatch Center opened with great splendor in November 2014, emphasizing the collaboration between Swatch and artists throughout its history. *Swatch Sabel* commemorated the 25th anniversary of Swatch in the Philippines and was the result of a partnership with renowned Filipino painter Benedicto "BenCab" Cabrera.

PRESENCE

SWATCH & ART

"FACES & TRACES" In Shanghai, Swatch celebrated the third anniversary of the artist-in-residence program at the Swatch Art Peace Hotel with a special exhibition on the hotel premises called "Faces & Traces", which presented examples of work by the 139 artists who had lived and worked in the unique art hotel in the program's first three years. The day got off to a great start with an international press conference in the hotel and continued with a Street Art Festival outside on the Bund, where a special live performance of the Swiss family of yodelers, Oesch's die Dritten, gave Bund-walkers a taste of authentic Swiss culture. Hundreds of invited guests showed up on the night to enjoy an amazing array of live art performances and art on display throughout the hotel. Great press and media coverage drew considerable attention to the exhibition. Separately in Shanghai, a large-scale installation introduced shoppers at the Grand Gateway Mall to the Swatch Art Peace Hotel and to the brand's long-term commitment to contemporary art and artists.

ITS 2014 Swatch ramped up its involvement in ITS (International Talent Support) in 2014 by creating a new competition category, ITS ARTWORK. Participants were asked to indulge in "lucid dreams" and to craft a visual expression of their own perception of the brand. Swatch's challenge to young designers was: "Unleash your fantasy. Make us dream!" And they certainly did! The winner of the Swatch Award was Italy's Virginia Burlina, who won an internship at the Swatch Lab in Zurich.

THE WATER TANK PROJECT The ticking clock of clean water accessibility was the focus of The Water Tank Project in New York City. Swatch invited ten artists to use rooftop water tanks as their canvases in an effort to help raise awareness of the importance of preserving the world's most essential resource.



SPORTS

Swatch Proteam member Richard Permin was on hand in Zurich for the premiere of *Days of My Youth*, a movie starring the renowned French freeskier and featuring awe-inspiring skiing in exotic locations. Swatch timed the launch of “Permin”, a limited edition Irony Chrono designed by the French legend, to coincide with the release of the movie. “When I’m skiing in the backcountry,” said Permin, “time fades away.”

The brand has backed action sports with great enthusiasm for years, and was delighted to return to the world of mountain biking as title sponsor of a big new event: Swatch Prime Line Munich. Back in the arena in support of the most spectacular and energetic of disciplines – mountain bike dirt jump/slopestyle, all eyes were on Swatch Proteam member and 2013 FMB World Tour champion Sam Pilgrim, whose signature backflip tuck no-hander and 720 secured him second place on the podium.

In September, Swatch sponsored the Swatch Women’s Pro Trestles 2014 in California on the seventh stop of the ASP Women’s World Championship Tour – an elite, 10-event series held around the world to determine the ASP Women’s World Champion. In addition to the Swatch Girls Pro France 2014 in August in Seignosse-Hossegor (France), an ASP 6-Star Qualification Series (QS) event now in its fifth year, the title sponsorship reaffirmed the brand’s ongoing support for women’s surfing.

SWATCH CLUB

2014 was a crucial year for the Swatch Club. A new strategy was implemented to attract new recruits and gave current members a chance to discover new products and limited-edition watches in a new retail environment. The annual club watch, White Loop, was presented during an inspiring round-the-world tour in March 2014. The Club also re-integrated its customer care and fulfillment services in six languages and decided to work with a new CRM system to prepare a fully integrated loyalty strategy. Worldwide fulfillment services were optimized and communication was improved. International events were held in Ascona (TI) and Stresa (Italy) as well as in Las Vegas – the latter to call attention to the importance of a global approach in the Club’s strategy.

The importance of the Gold and Pioneer (G&P) members to the Club was underscored with more local events in each of the active markets in the four pillars: Sports, Music, Art & Fun. Swatch Up Your Night was developed to reach younger members and to develop the community of members worldwide. The club also worked hand in hand with the Sports department and generated a new range of events to enhance Swatch’s commitment to sports.

In 2015 Swatch Club will be 25 years old and the G&P community will celebrate its 20th anniversary.



ADVERTISING

A key advertising highlight of 2014 was the Scuba Libre summer campaign, which ran from June to August with press ads, out-of-home, and “fluorescent” 3D TV commercials shown at points of sale and in 3D cinemas. The campaign fused nostalgic pop with modern expressionism, combining an underwater world with flashy neon-light sea creatures coming to life in an urban space. A celebration of colors, brightness and freedom, the campaign featured an Italian band playing a cover version of the Bill Haley song, “Me Rock A Hula”.

INTERNET

The “Adventures of the Gingerbread Girl” game was on the Swatch website in November and December.

THE SWATCH EYE

2014 saw the publication of two new issues of *The Swatch Eye*, which brings readers closer to the brand and its values with a series of behind-the-scenes reports and photo-stories focusing on Swatch personalities, events and product launches around the world. The paper is also published on swatch.com.



www.omegawatches.com



TIME MASTERED

TRENDS

In 2014, Omega continued to distinguish itself through its technological and material innovations. Its anti-magnetic Master Co-Axial calibers set a new quality standard for the industry. Plans for the Official Certification of the watches by the Swiss Federal Office of Metrology were announced in December.

The year's breakthrough product, the Speedmaster Dark Side of the Moon whose case is crafted from a single block of ceramic, was a global phenomenon that attracted a new demographic to the brand.

While partnerships with the GoodPlanet Foundation and Orbis International expressed Omega's dedication to social responsibility and enhanced the definition of its pioneering spirit, the brand maintained its status as the world's leader in sports timing at the Sochi 2014 Olympic Winter Games, where it served as Official Timekeeper for the 26th time. A long-term extension of the contract with The PGA of America underscored Omega's commitment to golf.

Omega continued to streamline and optimize its distribution in 2014, adding to its global network of monobrand boutiques and carefully-selected retailers at the world's best shopping addresses.

CREATION

MASTER CO-AXIAL TECHNOLOGY

In 2014, Omega introduced its groundbreaking anti-magnetic technology in seven Master Co-Axial calibers that equipped both the men's and women's collections. The watches resist magnetic fields greater than 15000 gauss, meeting a challenge that has perplexed horologists for centuries.

THE OMEGA SEAMASTER AQUA TERRA MASTER CO-AXIAL

The Seamaster Aqua Terra Master Co-Axial was introduced in 38.5 and 41.5 mm cases in a bicolor blend of 18K red or yellow gold and stainless steel or in understated stainless steel. The polished and brushed case has a polished bezel and a matt-polished screw-in crown. At the heart of each is the Master Co-Axial caliber 8500.

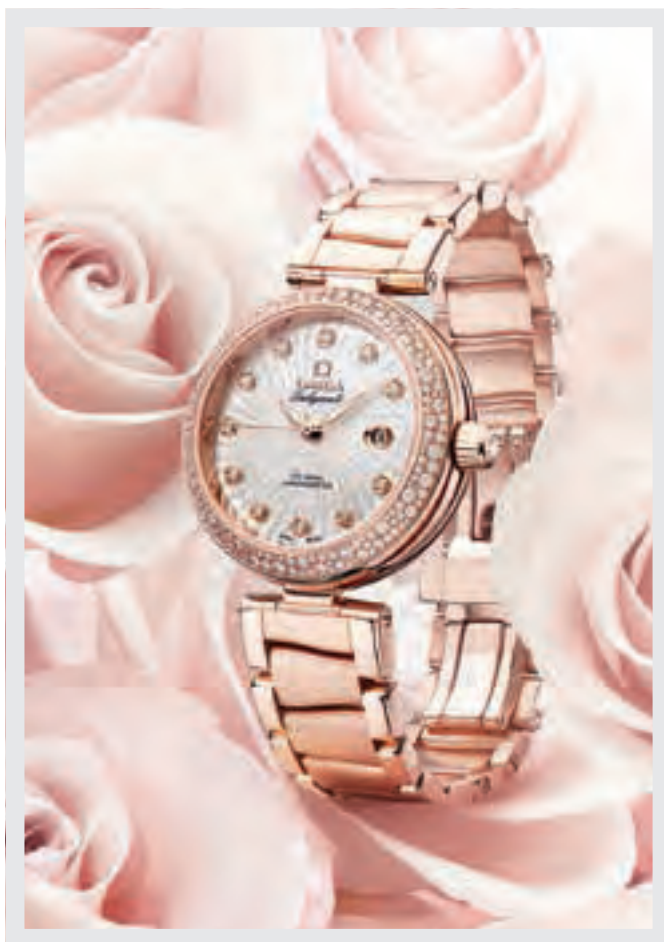
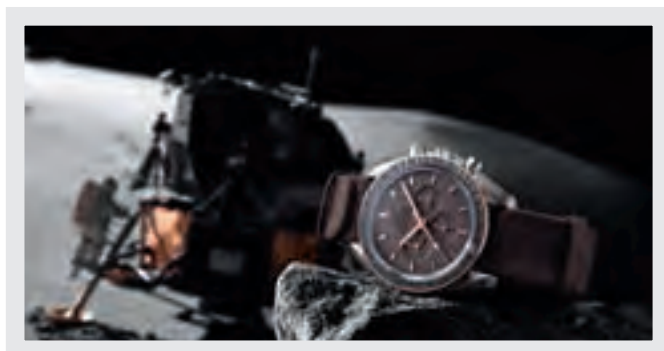



THE OMEGA SEAMASTER 300 MASTER CO-AXIAL

The 41 mm Seamaster 300 Master Co-Axial, inspired by a 1957 icon, features Omega's latest technical and material innovations. It has been crafted in a selection of metals including stainless steel, 950 platinum, grade 5 titanium and 18K Sedna gold or in bicolor options. The Seamaster 300 is powered by the Master Co-Axial caliber 8400/8401.

THE OMEGA DE VILLE TRÉSOR MASTER CO-AXIAL

The timeless De Ville Trésor Master Co-Axial is distinguished by a thin (10.6 mm) case in polished 18K Omega Sedna gold, 18K yellow gold or 18K white gold. A vintage Clous de Paris structure adds to the appeal of the opaline dial. It has a unique, manually-wound Omega Master Co-Axial caliber 8511.

THE OMEGA SPEEDMASTER PROFESSIONAL APOLLO 11 45TH ANNIVERSARY LIMITED EDITION

The Speedmaster Professional Apollo 11 45th Anniversary Limited Edition commemorates the first lunar landing and celebrates its link to the chronograph that was part of the adventure. Its 42 mm brushed grey grade 2 titanium case with a touch of gold recalls the colors of the Moon and the Apollo 11 lunar and command modules. An 18K Omega Sedna gold bezel is enhanced by a matt black ceramic ring with a tachymeter scale. It is fitted with the caliber 1861.



THE OMEGA SPEEDMASTER GREY SIDE OF THE MOON

The Speedmaster Grey Side of the Moon was inspired by the lunar dust that recorded each human footprint on the Moon. This 44.25 mm watch is crafted from white ceramic that has been transformed in a high-temperature plasma furnace to shimmering metallic grey. The case, caseback, bezel, crown, pushers and buckle of the timepiece are made from the same ceramic material. The Super-LumiNova tachymetric scale on the brushed ceramic bezel is another first.

THE OMEGA CONSTELLATION PLUMA

The Constellation Pluma combines a state-of-the-industry mechanical movement with timeless style. Its name hints at the delicate design accentuating the dial. The Pluma models have mother-of-pearl dials engraved with a wavy pattern that recalls the gentle lines of a feather.



PRESENCE

Omega's media presence started dramatically at the Sochi 2014 Olympic Winter Games in February. The brand's global profile was maintained throughout the year with major events, product launches, sports timing at international competitions and partnerships with socially responsible organizations. These activities were supported by dedicated advertising, a dynamic web and social media presence and focused public relations in every market.

MASTER CO-AXIAL

At Baselworld 2014, Omega presented its Master Co-Axial calibers, mechanical movements distinguished by their ability to resist magnetic fields greater than 15000 gauss. The calibers set a new quality standard and remained a centerpiece of Omega's communications throughout the year.

MASTER CO-AXIAL OFFICIALLY CERTIFIED

In December, Omega announced that it had established a partnership with the Swiss Federal Institute of Metrology (METAS) to establish a new quality certificate for watches. To earn the Officially Certified distinction, Master Co-Axial watches will be tested for their precision during and after exposure to magnetic fields greater than 15000 gauss, for autonomy and for water resistance.

SPEEDMASTER DARK SIDE OF THE MOON

Events around the world celebrated the black ceramic Speedmaster Dark Side of the Moon. The watch was a global success and has attracted a new generation of enthusiasts to Omega chronographs.



DE VILLE TRÉSOR

With a thin 18K gold case, timeless design and Master Co-Axial caliber, the stylish, vintage-influenced De Ville Trésor resonated with Omega fans when it was launched at Baselworld and attracted even more attention when brand ambassador George Clooney wore one at his wedding.

SPEEDMASTER PROFESSIONAL APOLLO 11 45TH ANNIVERSARY LIMITED EDITION

The Speedmaster Professional Apollo 11 45th Anniversary Limited Edition honored the legacy of the watch Buzz Aldrin wore on the Moon in 1969. The brand ambassador and former astronaut participated at events celebrating the new chronograph, its famous ancestor and his role in one of humankind's greatest adventures.



SEAMASTER AQUA TERRA "GOLDFINGER"

A one-of-a-kind 18K gold Seamaster Aqua Terra was created to celebrate the 50th anniversary of *Goldfinger*. The unique timepiece sold for 106000 Swiss francs at an exclusive online charity auction in September. Proceeds benefitted the National Society of Prevention of Cruelty to Children (NSPCC).

GEORGE CLOONEY IN SHANGHAI

In Shanghai, George Clooney was the star attraction at *Le Jardin Secret*, an event that raised awareness of Orbis International and showcased the new Aqua Terra timepieces. Clooney was joined by Orbis International CEO Jenny Hourihan, Omega President Stephen Urquhart, and two youngsters whose eyesight had been restored by the Orbis International team.

NICOLE KIDMAN IN SEOUL

Omega celebrated its De Ville Butterfly wristwatches with brand ambassador Nicole Kidman at an event at the elaborately decorated Dongdaemun Design Plaza (DDP) in Seoul in October. The Oscar-winning actress was joined by Swiss singer/songwriter Bastian Baker and Omega President Stephen Urquhart in the South Korean capital.



THE SOCHI 2014 OLYMPIC WINTER GAMES

Omega proudly assumed its responsibilities of Olympic Games Official Timekeeper for the 26th time as spectators and sports fans around the world set their sights on Sochi, Russia and the XXII Olympic Winter Games. In the time leading up to the Games, Omega unveiled Countdown Clocks in nine major cities in the host country.

THE OMEGA PAVILION

Olympians, legends and artists were among the prominent guests who visited Omega's activity hub in the Olympic Park. Special events featured Olympic gold medalist and brand ambassador Chad Le Clos, space legends General Thomas Stafford and Major General Alexey Leonov, and IOC President Thomas Bach.

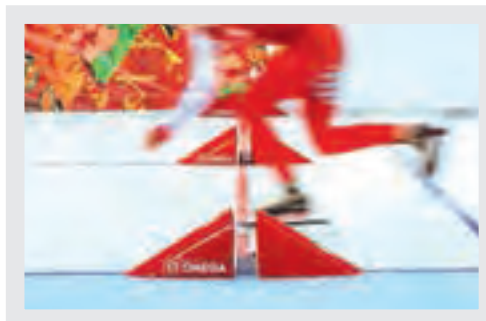

ADVERTISING AND PROMOTION

To promote its involvement in the Olympic Games, Omega created a new version of its acclaimed Co-Axial television commercial where three-dimensional watch components were used to re-create the winter sports represented at the Games. A second three-dimensional video about speed skating technology was played for guests at the Omega Pavilion.

TIMEKEEPING EQUIPMENT

Together with the International Ice Hockey Federation, Omega developed the IH Whistle Detection system which made its debut in Sochi. The automatic system monitors the audio signal throughout the game and stops the clock as soon as it detects the sound of a referee's whistle, ensuring the accuracy of the stopped time and resulting in additional playing time.

OMEGA'S OLYMPIC GAMES-INSPIRED WATCHES

Omega created three special edition wristwatches to honor the Sochi 2014 Olympic Winter Games: a black 45.5 mm Seamaster Planet Ocean, its white 37.5 mm counterpart and the barrel-shaped Sochi Petrograd, which was inspired by a unique piece in Omega's Museum Collection.

OTHER SPORTS

THE PGA CHAMPIONSHIP Omega announced the extension its partnership with The PGA of America through 2022. The announcement was made at Valhalla Golf Club in Louisville, Kentucky, the site of the PGA Championship. Less than a week later, brand ambassador Rory McIlroy won the Championship, one of golf's four majors.

THE NANJING 2014 YOUTH OLYMPIC GAMES In August, Omega served as Official Timekeeper of the Nanjing 2014 Youth Olympic Games, a role it has assumed since the inaugural edition in 2010. Omega family members Chad Le Clos and Michelle Wie were named YOG ambassadors.



EUROPEAN ATHLETICS CHAMPIONSHIPS IN ZURICH

In August, Omega filled the role of Official Timekeeper for the 2014 European Athletics Championships. Newly unveiled time-keeping equipment included the Scan'O'Vision Myria photo-finish camera, a new false start detection system and two types of upgraded scoreboards.

SOCIAL

TIME FOR THE PLANET In June, Omega helped organize two environmental conservation programs in Indonesia. The initiative, Time for the Planet, was implemented with Yann Arthus-Bertrand and the GoodPlanet Foundation to protect oceans and underwater ecosystems and to educate local communities, manage the region's natural heritage and create protected marine areas.

ORBIS INTERNATIONAL In 2014, Omega continued to support Orbis International, an organization that, with its Flying Eye Hospital, leads the fight against avoidable and curable blindness around the world. Media visits in China, the Philippines and Indonesia raised awareness of Orbis International.

OMEGA MUSEUM

The Omega Museum continued to enhance its displays and themes as well as its audio guide system in 2014, and included new highlights and special exhibits from the brand's rich history. The Museum also organized exhibitions at other institutions, sharing Omega's story around the world.

OMEGA ONLINE

omegawatches.com, the official website, had more visitors than ever before, driven particularly by an increase in traffic in China, Japan, South Korea, Latin America, Russia and the USA. It is available in 12 languages. There was also an impressive increase in the number of visitors from tablets and smartphones. The Seamaster remained the world's "most searched" watch model by name.

Omega's active presence in interactive media was supported with the launch of an international e-newsletter, two new pages on social media sites, a series of online video manuals and a new YouTube channel.

OMEGA LIFETIME

In 2014, *Omega Lifetime*, the brand's twice-yearly lifestyle magazine, was again published in ten languages. The year saw the publication of the Winter Olympic and the Master editions.



FINE JEWELLERY

The year's highlight in Omega's Fine Jewellery offering was the newly interpreted Flower Collection. Like the rest of the brand's jewelry pieces, they are elegantly feminine and perfectly complement Omega's watches, reflecting their luxurious universe.

FINE LEATHER

Striking a balance between the worlds of innovation and tradition, the Fine Leather collection was again available through the brand's global boutique network. The exacting standards of skill, design and superior materials long associated with Omega timepieces were creatively expressed in these high-end leather goods.

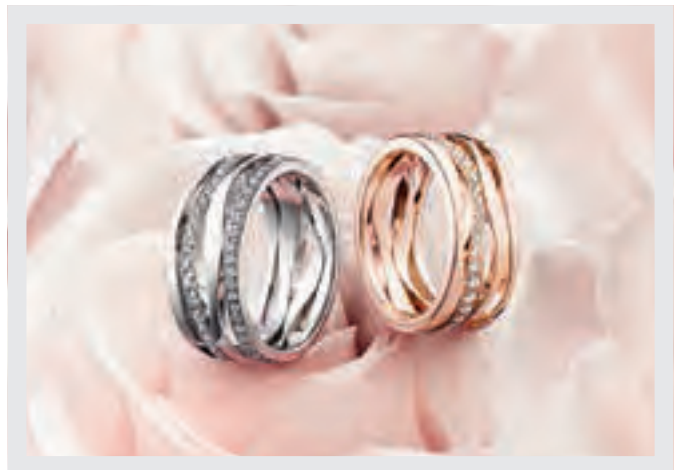



www.breguet.com

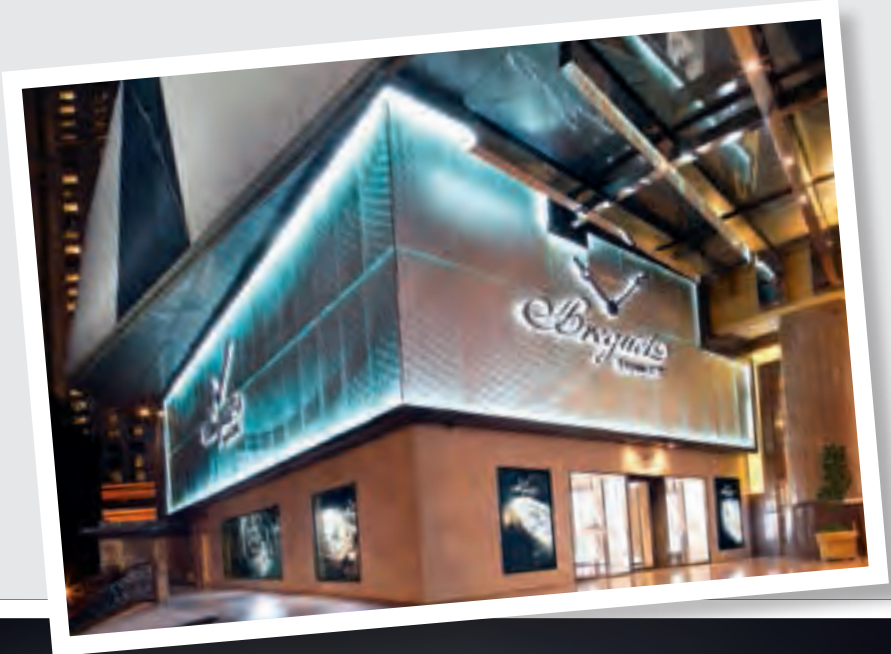

240 YEARS OF WATCHMAKING INNOVATIONS

TRENDS

A key player in the watchmaking industry, Breguet has registered more than 200 patents since its foundation in 1775. Firmly rooted in the brand's fascinating ability to innovate, 2014 gave fans of exceptional timepieces an opportunity to discover some of the many contributions it has made to watchmaking. The high-tech traveling exhibition called "Breguet, Innovations That Wrote History" crossed continents, offering an understanding of Breguet's technical developments and their impact on the science of measuring time.

Parallel to this, roadshows dedicated to the first wristwatch and tourbillon, inaugurated in 2012 and 2013 respectively, extended their tours. Their phenomenal success in Asia particularly justified a grand return to China. Russia was also among the key destinations of these retrospectives, as the exhibition devoted to the tourbillon was presented at GUM, one of Moscow's most prestigious department stores.

These events were an opportunity for Breguet, under the leadership of its President, Marc A. Hayek, to visit the markets and strengthen its ties with clients. This spirit of closeness also prevailed at the presentation of the Classique Tourbillon extraplat automatique 5377 in China and Russia. The centerpiece of 2014, this seven-millimeter thick model with a movement of three-millimeters is emblematic of the technical and aesthetic excellence for which Breguet strives unceasingly. Repeated investments in the research and development of new technologies and new materials were responsible for the lighter titanium carriage and the Breguet silicon balance spring incorporated into the 581DR caliber with which this Grande Complication model is equipped. Hailing Breguet's progress in the realm of chronometry, media and watchmaking experts greeted it with great enthusiasm and the *Robb Report* magazine elected it 'Best of the Best' in the "Men's Watches, Dress Watch" category.

Breguet was also honored with the most prestigious prize at the 2014 edition of the Grand Prix d'Horlogerie de Genève (GPHG) for its Classique Chronométrie model, which won the coveted "Aiguille d'Or". The GPHG Public Prize went to the Classique Dame 9068. These distinctions followed Marc A. Hayek's second consecutive "Man of the Year" title awarded by specialist magazine, *Revolution*.

2014 also saw the end of the moves following the building of the extension to the Manufacture that began in 2011 at the





L'Orient site (Vallée de Joux, Vaud). The brand will now focus its efforts on the development of the *Maison du Patrimoine* (Heritage House). Devoted to Breguet's rich history, this building will be constructed at L'Abbaye (Vallée de Joux, Vaud) and will house vintage pieces and archival documents to which Marc A. Hayek has continuously added. In May and November 2014, four additional items were acquired at auctions. Purchased for nearly 1.5 million Swiss francs, pocket watches no 4039, 1176, 1135 and 1576 joined the countless treasures harbored by the Breguet Museum (Paris, Zurich, Shanghai).

In addition to these milestones, there was continued demand for Breguet products throughout 2014. The feminine collections in particular underwent considerable growth. The United States, the Middle East and Europe remained stable markets, while sales experienced strong development in Japan where the brand acquired significant market share.

CREATION

CLASSIQUE TOURBILLON EXTRA-PLAT AUTOMATIQUE 5377

Breguet's Classique Tourbillon extra-plat automatique 5377, which is an exceptional piece, returned to the stage nobly dressed in platinum. It displays an off-center tourbillon whose titanium carriage houses a Breguet silicon balance spring as well as an escapement especially developed for it. These characteristics enable the caliber 581DR movement of this Classique Grande Complication to reach a frequency of 4 Hz, which is high for a tourbillon. This does not imply any loss of power reserve, as the patented high-energy barrel keeps the reference 5377 going for up to 90 hours off the wrist. To keep the thickness of the movement down to 3 mm in a 7-mm-thick case, Breguet designed a peripheral rotor in platinum, winding in both directions of spin.

CLASSIQUE TOURBILLON QUANTIÈME PERPÉTUEL 3797 AND CLASSIQUE TOURBILLON QUANTIÈME PERPÉTUEL "SQUELETTE" 3795

The Classique collection was enhanced with two perpetual calendar models, in which particular attention was paid to the styling for a more intuitive display of the indications. The amount of information displayed on the dial can be confusing, so Breguet has added a third dimension. By lifting the hours and minutes chapter to the foreground, the timepiece draws attention to the essential information. A further glance takes in all the other indications. The watches are equipped with an offset sapphire disc. Decorated with metallic Roman numerals, the opaque chapter ring stands out from the rest of the dial and reveals the time instantly.

Even though the reference 3797 can already be considered to be a masterpiece, Breguet's watchmakers chose rather to compound the complexity by making an even more spectacular ver-



sion: the reference 3795. The dial vanishes to make room for a skeleton version revealing all the sophistication of the movement's construction.

CLASSIQUE DAME 9068

Breguet has from its beginnings taken on the task of designing timepieces exclusively for women, combining watchmaking know-how with elegant design, a philosophy that gave rise to the Classique Dame 9068. This particularly slim watch shows the hours, minutes and seconds as well as the date in an aperture. Once again, the heart of this watch is a mechanical movement with a silicon escapement and balance spring. Taste and charm come naturally into play because the dial is decorated with a hand-crafted engine-turned motif, while the bezel and lugs are set with brilliant-cut diamonds.

REINE DE NAPLES "PRINCESSE" 8968

Inspired by the creation of the first wristwatch by Abraham-Louis Breguet for Caroline Murat, the Reine de Naples watch is identified by the delicate shape of its case, which has become emblematic and here is seen in a resolutely contemporary timepiece. The Reine de Naples "Princesse" 8968 thus proclaims its own modern and stylized identity. While retaining its egg shape, the case is curved to fit the shape of the wrist. The dial, with its hand-crafted engine-turned patterns, uses perspectives and contrasts to capture attention. It follows the line of the case, creating an illusion of depth that highlights the hour markers, also curved, at 12 and 6 o'clock.

PRESENCE

EXHIBITIONS

The "Breguet, Innovations That Wrote History" exhibition, a roadshow presenting a high-tech selection of eight key inventions brought to life by demonstrations, was launched at the Cité du Temps in Geneva, attended by 500 guests. Also launched in Basel during Baselworld, it took off for China in the second half of 2014 with Shanghai as the first Asian stop. Here, it was celebrated with a gala evening at which the Classique Tourbillon extra-plat automatique 5377 was launched in that country. The exhibition then moved on to Florence in Italy, followed by the cities of Taipei and Kaohsiung in Taiwan, before returning to Zurich in Switzerland.

Presented in 2013, the "Breguet, The Innovator" exhibition retraces the story of the creation of the tourbillon, and was hosted in China, Singapore and Russia, where it took up residence in GUM, the luxury commercial gallery located on Red Square. After closing time for the public, some 700 guests were hosted there for a splendid evening attended by members of Breguet's management.

PARTNERSHIPS

Breguet continued its policy of commitment to institutions actively involved in the areas of art and culture. This unflinching involvement is a key element of the brand's strategy and vision, which are committed to the preservation of our cultural and historic heritage.

Principal sponsor of the renovation of the Louis XIV and Louis XVI rooms at the Louvre, in conjunction with the museum, the manufacture from the Vallée de Joux celebrated the reopening of this approximately 2500 square-meter space. More than 300 personalities invited to this international event celebrating the



achievement of the remarkable sponsorship had an exceptionally intimate opportunity to discover the redeployment of the 18th century decorative arts collection and attend a gala dinner under the museum's famous glass pyramid. The successful conclusion of this longstanding patronage was the subject of a number of exclusive editorial programs broadcast on CNN, as Breguet had sponsored the second half of the program "Inside the Louvre" launched in December 2013. This association with CNN was emphasized by a campaign broadcast on CNN International, as well as a digital campaign on CNNi.com and on the station's iPad application.

In Spain, Breguet renewed its support for the cultural festival, Majorca's Formentor Sunset Classics, a series of concerts bringing together great names from the international classical arena.

In Russia, the brand's visibility was reinforced through two major cultural endeavors. One of the official sponsors of the Theatre of the Nations since 2013, Breguet was once again at the side of this prestigious institution at the première of "Hamlet/Collage". In Saint Petersburg, with the Tourbillon boutique, Breguet supported the Artist Foundation at a charity concert from which the profits went to a medical research program.

2014 was also marked by the consolidation of Breguet's presence in the United States and the announcement of its exclusive association with the Fine Arts Museums of San Francisco. This new exhibition will be organized in the Legion of Honor building in September 2015, with the largest collection of vintage Breguet watches ever to be exhibited in the United States. The partnership between the brand and the Las Vegas Smith Center for the Performing Arts cultural center was extended, while further support was also pledged to Carnegie Hall in New York.

In Belgium, Breguet signed a partnership focusing on history and memory with the Hougoumont Farm, the last remaining vestige of the Battle of Waterloo, where the official ceremonies

celebrating the battle's reenactment will take place in 2015 during the commemoration of the bicentennial of the event.

BOUTIQUES

The architectural extension and development of its boutique network remained a central concern for Breguet. With its expansion in China, the brand inaugurated a new location measuring some 200 square meters in the shopping arcades at the Peninsula Hotel in Shanghai, shortly after the opening – in the same city – of the largest Breguet boutique in the world. Still in Asia, the brand also moved to the Starhill Gallery in Kuala Lumpur, a mall located in one of the most prestigious areas of the Malaysian capital.

Continuing the refurbishment of its boutiques on the basis of the new brand identity concept, in the United Kingdom, Breguet celebrated the reopening of its London shop located in the heart of Mayfair. Renovated and extended, it now benefits from a space of around 190 square meters. In Tokyo, the Ginza boutique also had a facelift and its reopening was celebrated at a local event attended by VIP personalities and journalists. Finally, the Breguet boutique at the Place Vendôme in Paris, which was renovated during 2014, should be opening to the public soon.



BREGUET HIGH JEWELRY

2014 was characterized by very significant sales, and despite a slight drop, the results for the brand remain comparable to those in the preceding financial year. Les Volants de la Reine High Jewelry watch in particular recorded a highly positive number of orders at its Baselworld presentation.

CREATION

BREGUET LES VOLANTS DE LA REINE

A tribute to the regal clothing worn by Marie-Antoinette, Queen of France and Breguet's first woman client, this new jewelry collection is popular due to its shapes reminiscent of the most beautiful silks and pleated laces of the dresses of the time. With the Les Volants de la Reine, metal becomes frivolous, bringing to mind the precious evanescence of moving fabric, while a myriad diamonds bring brilliant sparkle to its finery. The timepiece is complemented by a set consisting of a necklace, ring and earrings. Each of these jewelry creations features one or more blue sapphires as its central motif.

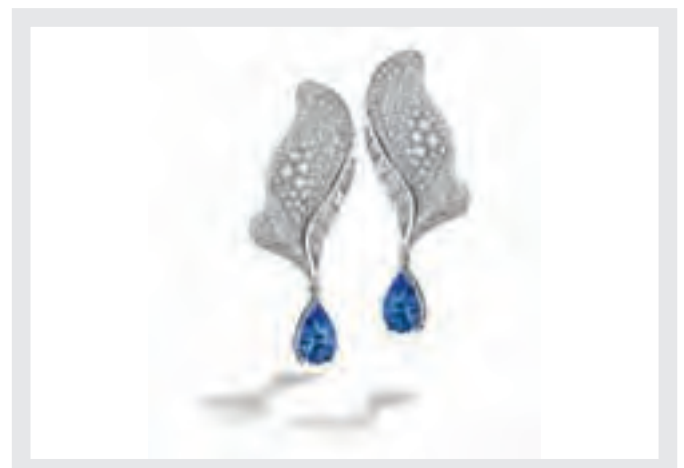



HARRY WINSTON®

www.harrywinston.com



A PROMISE OF A FUTURE AS BRILLIANT AS THE PAST

TRENDS

2014 marked Harry Winston's first full year as a part of Swatch Group. Under the direction of President Nayla Hayek, Harry Winston continued to solidify its position as one of the most prestigious brands in the luxury industry, by preserving the rich heritage and remarkable legacy at the heart of its story, while focusing on and investing in the key areas of the business that will have the greatest impact on its future – the development of new product and gemstone acquisition, the expansion of its retail distribution network and renovation of existing salons, and the implementation of a new global marketing campaign.

For more than 80 years, Harry Winston has represented the ultimate in rarity, elegance and creativity. While it shares its history with some of the world's most exceptional gemstones, Hollywood screen legends and royal dignitaries, Harry Winston's reputation for creating the most exceptional fine jewelry and timepiece collections, coupled with its commitment to the highest quality standards in craftsmanship and design, are the qualities that have – and always will – define the House.

This dedication to excellence began with its founder, Mr. Winston, whose passion for incredible stones led him to establish a lasting legacy as "The King of Diamonds." In continuing to uphold this remarkable tradition, in May 2014 the brand acquired an incredible 13.22-carat flawless, fancy-vivid blue diamond, named the Winston Blue. Described as the largest of its kind, the magnificent pear-shaped stone joined the 101-carat Winston Legacy Diamond, which was acquired in 2013, and reaffirmed the Brand's promise to hold to the core values and principles it was founded upon, including the motto, "Rare Jewels of the World."

Building upon its portfolio of legendary designs, the Brand introduced a new high jewelry collection called Secrets by Harry Winston, as well as exquisite one-of-a-kind jewelry masterpieces known as the "Incredibles." For its collections, line extensions of the House's most defining signature motifs – such as the Winston Cluster, Diamond Loop, and Sunflower – were added to its existing product assortment, along with a new men's Zalium collection.

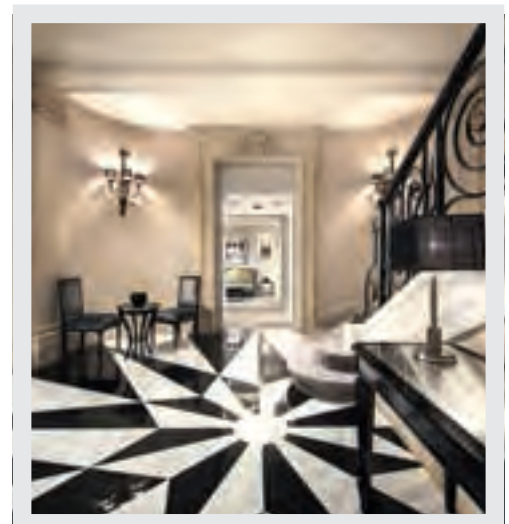



During 2014 Harry Winston continued to build its timepiece business. Using the knowledge and expertise of Swatch Group, Harry Winston successfully introduced new, complicated models at the Baselworld trade fair, which included movements developed by Blancpain and ETA.

With the opening of five new salons and the renovation of two existing locations, including its historic flagship on Avenue Montaigne, Harry Winston expanded its global retail distribution network, exposing the brand to more luxury consumers worldwide.

Harry Winston also strengthened its international visibility through the debut of a new global advertising campaign that seamlessly married its deeply-rooted past with its brilliant future. Mimicking the reflections and facets of a diamond, the campaign features the brand's most celebrated collections set against a backdrop of iconic New York City landmarks – including its Fifth Avenue salon.

In looking towards the future, Harry Winston will continue to invest in the key areas of the business that will help to shape and define its legacy for years to come.

CREATION

SECRETS BY HARRY WINSTON

Through the introduction of its newest high jewelry collection, Secrets by Harry Winston, the Brand presented a fitting tribute to its founder, with a series of new designs that explore Mr. Winston's own magical mystique, while demonstrating the House's commitment to his pioneering vision in craftsmanship and design.

At first glance, the collection is an exquisite example of the House's most celebrated designs and techniques presented through distinctly different themes. But behind the brilliance of each gem, there is more than meets the eye, with each unique piece containing an incredible secret.

In Secret Cluster, the House's most iconic motif – the Winston Cluster – sets the stage for a series of enchanting and unexpected surprises, from a delicate perfume bottle to a precious locket to an exquisite emerald hidden behind a sculptural cluster bracelet that sparkles from every angle. In Secret Wonder, exquisite medallions set with a starburst of round and pear-shaped diamonds, rotate to reveal a symphony of sapphires, diamonds, and aquamarines hidden on the other side; while Secret Combination creates an ever-changing arrangement of bracelet and necklace styles, through detachable strands of fancy-cut diamonds.

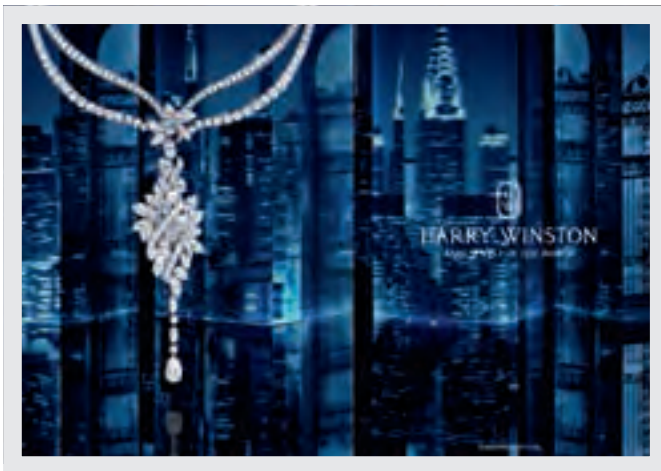

THE INCREDIBLES

The creation of a Harry Winston jewel begins with a study of the extraordinary – the finest diamonds and the rarest gemstones in the world. Expertly chosen for their superlative quality, these luminous stones are the sparks that ignite the imaginations of Harry Winston designers and craftsmen, who work closely together to transform each individual gem into collective works of art. The end results are jewels so remarkable and so rare that they can only be described as Incredible.

Following in this honored tradition, Harry Winston continued to introduce new one-of-a-kind high jewelry suites that are magnificent in scale and unmatched in quality. Fashioned from diamonds, rubies, sapphires, and emeralds, each stone is meticulously hand set to draw emphasis to its individual brilliance and radiant fire. Translating decades of tradition into modern masterpieces, each unique piece draws references from the Winston Archives.

EMERALD CLUSTER

The Emerald Cluster masterfully captures Harry Winston's pioneering diamond-driven philosophy, in an exquisite high jewelry timepiece. Developed by Mr. Winston in the 1940s, the cluster technique is achieved when different shapes of diamonds are grouped together and set at varying angles, creating a highly dimensional design that allows each individual stone to capture the maximum light from all directions. In this striking interpretation, designers and master craftsmen explore the interplay between four different diamond-cuts – baguette, round, pear and marquise. Handcrafted in platinum, the intricate design relies on different techniques in diamond setting, channel-set and prong-set, to finesse each stone's distinct geometry into a final composition of pure, sculptured brilliance. The stunning emerald-cut shaped case is finished with baguette diamonds and nestled within a cluster of pear-shaped stones, reflecting the harmonious balance between fine jewelry and fine watchmaking.

ULTIMATE EMERALD SIGNATURE

Ultimate Emerald Signature embraces the House's fine diamond heritage with a case that features an incredible array of remarkable stones – 192 brilliant-cut diamonds, 38 baguette-cut diamonds, 24 marquise-cut diamonds, and a single one carat emerald-cut diamond placed at its center. Gently opening the exterior reveals the dial that sparkles with a full diamond pavé surface. More than 100 hours were required to hand set this exceptional creation.



HISTOIRE DE TOURBILLON 5

Harry Winston's Histoire de Tourbillon is a sophisticated collection of limited edition timepieces dedicated to the craftsmanship of one of the most revered and complex horological complications. Launched in 2009, each Histoire de Tourbillon underscores Harry Winston's continued pursuit of excellence in innovation, by presenting the tourbillon in a series of spectacular new forms. Further demonstrating its dedication to freedom and excellence in design, Histoire de Tourbillon 5 is the first in the series to be crafted in rose gold. This variation continues in the open-worked movement, which is black instead of the conventional grey. From its quest for perfect symmetry, to the careful balance between construction and volume, to its bold choice in color – the Histoire de Tourbillon 5 expresses the House's creative instincts in design, and pushes the series to the next level of innovation.



PRESENCE

SALON OPENINGS

One of the priorities for Harry Winston is to increase the brand's global visibility by opening new salons in the most prestigious locations around the world. In 2014, the brand opened two new salons in the United States – a salon in Waikiki and a second location in Las Vegas. The most significant expansion for the brand occurred in Europe, with new salons in Cannes, St. Moritz and its first location in Italy, on Rome's prestigious via dei Condotti.

2014 also saw the reopening of Harry Winston's historic flagship salon on Avenue Montaigne in Paris, following a more than year-long renovation.

RED CARPET

Known as the "Jeweler to the Stars", Harry Winston has shared a glamorous part of Hollywood's dazzling history for more than seven decades. As the very first jeweler to loan diamonds to an actress for the Academy Awards in 1944, Mr. Winston helped to revolutionize modern-day red carpet glamour.

Harry Winston's exquisite fine jewelry and timepiece collections continued to adorn Hollywood's brightest stars, including Charlize Theron, Gwyneth Paltrow, Reese Witherspoon, Jared Leto and Will Smith, at some of the most acclaimed events of the year. From the Golden Globe Awards to the Academy Awards to the MET Costume Institute Gala to the Cannes Film Festival and the Hollywood Film Awards, in 2014 Harry Winston jewels were prominently featured on red carpets worldwide, proving they are true stars among the stars.



PHILANTHROPY

Supporting local causes and giving hope to those in need is a longstanding House tradition that continues through the Harry Winston Brilliant Futures™ Charitable Program, which proudly supports leading organizations around the world whose mission is to enable healthy and brilliant futures for young people in need.

In the USA, Harry Winston extended its support to organizations based within its salon communities, including the Harlem Academy, Voices For Children, and CHOC Children’s Hospital. Additionally, in April 2014 Harry Winston announced a gift of one million dollars to the UCLA Children’s Discovery and Innovation Institute, part of the Mattel Children’s Hospital UCLA, to establish the Harry Winston Fellowship Fund. As the first corporate sponsor of Mattel Children’s Hospital UCLA’s innovative pediatric fellowship program, Harry Winston will support the work of young pediatric physician-scientists who are conducting research to prevent, treat, and cure disease and illness in children. Harry Winston Fellows will be selected annually by an internal selection committee; the first three recipients were announced in October 2014.

In Asia, the Harry Winston Hope Collection made its debut in Singapore to benefit EQUAL, a program of the Equestrian Federation of Singapore, which uses pioneering horse-based lessons to engage and connect with at-risk children, to help them regain their confidence, motivation and positive spirit. Harry Winston also entered the second year of its partnership with Chance for Children in Japan, and its fourth year with the International Youth Foundation in China.





www.blancpain.com



A TRADITION OF INNOVATION

TRENDS

For Blancpain, 2014 was marked by the strengthening of its three communication universes spanning the underwater world, automobile sports and the art of living.

The major project for the year, the Blancpain Ocean Commitment, served to consolidate the brand's longstanding commitment to raising awareness, increasing respect and protecting the underwater world. This overall concept brings together:

- Financial support for major scientific expeditions such as the Pristine Seas Expeditions with Blancpain under the auspices of the National Geographic Society and Laurent Ballesta's Gombessa project;
- The Ocean Commitment watch, as well as the Blancpain Ocean Commitment Circle which brings together all the owners of this limited edition watch;
- The book, *Fifty Fathoms – The Dive and Watch History 1953–2013*, which retraces the history of modern diving and the Fifty Fathoms diving watches;
- The blancpain-ocean-commitment.com website specially dedicated to the project.

For more than six years, Blancpain has unceasingly strengthened its presence in the realm of automobile sport and has made a name for itself as an international reference in GT races by partnering the most important championships. In 2014, automobile sport enjoyed the benefit of excellent media coverage, thanks notably to the success of television broadcasts through which the Blancpain GT series brought together three million spectators per race, representing a significant increase compared to 2013 in terms of both speed and endurance trials.

The links between Blancpain and the art of living have been further strengthened through partnerships with the greatest chefs and exceptional hotels:

- Blancpain announced its collaboration with Relais & Châteaux, making it the exclusive watchmaking brand to work with these establishments.
- Blancpain's privileged relationship with great chefs reached its peak thanks to an exclusive contract with Joël Robuchon, the one with the most stars in the world.

The Manufacture from Le Brassus (Vallée de Joux, VD) once again demonstrated its creative and innovative ability with the launch of four new calibers in particular, including a new 5 Hz chronograph and a tourbillon equipped with a 12-day power





reserve with a single barrel. The 2014 collection presented at Baselworld was one of the largest in the past few years and a great many new models were a success with retailers.

In 2014, Blancpain once again recorded a good year, despite various international economic upheavals. China, Hong Kong and Switzerland remained the main markets for the brand, which also gained new market share elsewhere, mainly in Italy, Spain, Singapore and Japan.

Blancpain continued the international expansion of its retail network with the opening of six boutiques, bringing the total number of its wholly-owned shops to 32:

- In July, the brand inaugurated its flagship boutique – the biggest boutique on American soil – in the heart of Manhattan on the famous Fifth Avenue.
- In September, the Manufacture opened its first boutique on the West Coast of the United States at the Forum Shops at Caesars in Las Vegas.
- Blancpain also strengthened its presence on the Asian markets with the opening of two new boutiques in South Korea and another at Hong Kong International Airport.
- Europe was not left out, with a new boutique inaugurated on New Bond Street, in the heart of London.

CREATION

FIFTY FATHOMS COLLECTION

THE BATHYSCAPHE WELCOMES A NEW 5 HZ CALIBER

The Bathyscaphe model is equipped with the new Manufacture Blancpain F385 movement. This caliber with a heart beating at 36000 vibrations per hour (5 Hz) is equipped with a chronograph mechanism controlled by a column wheel with a vertical coupling-clutch. It also features a flyback function serving to ensure instant zero-resetting and resetting of the chronograph simply by pressing the pusher at 4 o'clock. In aesthetic terms, this new Bathyscaphe reflects the collection's identity codes, while innovating with a 43 mm-diameter brushed black ceramic case.

VILLERET COLLECTION

12-DAY POWER RESERVE FOR THE NEW BLANCPAIN FLYING

TOURBILLON The new Manufacture Blancpain Caliber 242 takes things to the next level by improving the record set in 1998 by the Caliber 25, the world's first automatic tourbillon movement with an 8-day power reserve. This automatic-winding tourbillon is endowed with an exceptional 12-day power reserve achieved by a single barrel. For this new model in the Villeret collection, Blancpain has placed its technical expertise at the service of aesthetics. The automatic-winding and power-reserve mechanisms have thus been integrated into the thickness of the mainplate so as to enable hand-guilloché decoration of the bridges. Demonstrating a concern for fine-tuning every detail, the oscillating weight has been enlarged and openworked. On the dial side, the flying tourbillon has been enlarged to ensure a perfect view of the new design of the balance with its silicon balance-spring.



AN ENTIRELY SECURED NEW PERPETUAL CALENDAR WITH LARGE MOON-PHASE DISPLAY This new perpetual calendar model in the Villeret collection is fitted with the new Caliber 5939A automatic movement comprising 379 parts and measuring just 7.25 millimeters thick and 32 millimeters in diameter. While taking account of the Gregorian calendar's characteristic varying lengths of months and leap years, it also displays a large moon phase and small seconds at 6 o'clock. Entirely secured and protected, it enables smooth handling of the day, date and month indications – as well as the moon phases – at any time without risk of damaging the movement. The 42 mm-diameter case features four patented under-lug correctors, providing a discreet and practical means of adjusting the date indications and moon phase without any need for a dedicated tool. To ensure enhanced readability, the Grand Feu enameled dial is graced with broad painted hour-markers and well-spaced day and month indications with blued steel hands, as well as a large moon.

CARROUSEL, MOON PHASES: UNITING TWO ICONIC COMPLICATIONS Blancpain presents a movement associating the brand's two iconic horological complications: the carousel and the moon phase. This new model in the Villeret collection once again expresses the tradition of innovation driving the Manufacture. A complication that was all but forgotten for over a century, the carousel (also known as the *karusell*) was brought back to center-stage by Blancpain in 2008 with the world's first carousel performing a one-minute rotation. This new timepiece features all the signature characteristics of the Villeret collection: a double-stepped case, a Grand Feu enamel dial; hollowed sage-leaf hour and minute hands, and a blued steel serpentine date hand.

AN UNDERSTATED THREE-HAND WATCH GRACED WITH A GRAND FEU ENAMEL DIAL The Villeret collection welcomes a distinctively understated automatic watch with an 8-day power reserve. The domed Grand Feu enamel dial bears a date indication at 3 o'clock, as well as a central sweep-seconds hand. The use of Grand Feu enamel enables Blancpain to reaffirm its attachment to historical watchmaking skills. This material calls for successive layers of enamel fired at extremely high temperatures, while the enamel-painted numerals also undergo the stern test of the furnace.

WOMEN COLLECTION

HEURE DÉCENTRÉE SECONDE RÉTROGRADE: A WATCH SPECIALLY DEVELOPED FOR WOMEN Winner of the 2014 Grand Prix d'Horlogerie de Genève 2014 in the Ladies' Watch category, this model specially developed for women is a perfect blend of technical and aesthetic elements. As early as 1930, the Manufacture had grasped women's interest in horological complications that had hitherto been an exclusively masculine preserve. Ever since, Blancpain has constantly innovated by developing timepieces that are as beautiful inside as out, as confirmed by this new model in the Women collection. A vibrant anthem to femininity, this gold model is highlighted by two interlacing rows of diamonds, subtly evoking the brand's iconic double-stepped bezel. A gem-set wave on the mother-of-pearl dial separates the off-centered hours and minutes counter at 12 o'clock from the 30-second retrograde seconds indication at 6 o'clock. The sapphire crystal caseback provides a chance to admire the oscillating weight shaped like a five-petal flower dreamed up by Blancpain.



PRESENCE

BLANCPAIN OCEAN COMMITMENT

On October 9 Blancpain and its President, Marc A. Hayek welcomed friends and partners of the brand along with the press to Cap d'Antibes, to present the Blancpain Ocean Commitment. This project follows on from the historical continuity that links Blancpain to the underwater world and emphasizes its years of commitment to major scientific expeditions.

NATIONAL GEOGRAPHIC SOCIETY PRISTINE SEAS EXPEDITIONS

The number one partner of the Pristine Seas Expeditions with Blancpain for the fourth year, thanks to its indefatigable support, the brand encouraged the growth of this program which has made a name for itself as the main initiative for the protection of the oceans. More than 1.6 million square kilometers of marine areas have been protected to date, the most recent being off the coasts of Gabon and the United States. In September, President Obama announced a historic extension of the Pacific Remote Islands Marine National Monument, making it the largest protected area of ocean on the planet, with 1.2 million square kilometers. Blancpain is proud to note that important new partners, such as the Waitt Foundation, the Albert II of Monaco Foundation and the Leonardo DiCaprio Foundation, are following in its footsteps.

HANS HASS AWARD

During a ceremony in China, the committee of the Historical Diving Society Hans Hass Award, in partnership with Blancpain, awarded the Hans Hass Fifty Fathoms Award 2014 to Professor Cui Weicheng, Dean of the Hadal Science and Technology Center at Shanghai Ocean University as well as the Chinese State

Oceanic Administration. This prize is awarded in recognition of the excellence of work in the field of scientific research – of which the construction of their submarine, *Jiaolong*, is an example, as is their long-term vision on the manner in which the sea is explored.

GOMBESSA II: THE MYSTERY GROUPE

Following its meeting with the coelacanth, diver and biologist, Laurent Ballesta went to French Polynesia on a new scientific expedition with the aim of unraveling the mystery of grouper reproduction. This unparalleled experience will be revealed in a documentary broadcast on ARTE. A strong indication of Blancpain's commitment to the discovery of the sea, Marc A. Hayek personally supported this expedition by diving alongside Laurent Ballesta and his team.

BLANCPAIN, A PASSION FOR BEAUTIFUL MECHANICS

2014 was marked with the introduction of the Blancpain Sprint Series, a new one-hour race format. This discipline combines with the success of the Blancpain Endurance Series to create the Blancpain GT Series. Their television coverage made it possible to reach millions of viewers all over the world. The Lamborghini Blancpain Super Trofeo once again brought fans and drivers together in Europe, Asia and North America. Blancpain also partnered the ADAC GT Masters in Germany, as well as the British GT Championship in the United Kingdom.

BLANCPAIN AND THE ART OF LIVING

Convinced that there is a close relationship between gastronomy and traditional watchmaking, Blancpain nurtures close links with the art of living. Passion, know-how, precision gestures and attention to detail of hand craftsmanship are all shared values of these universes. It is therefore only natural that Blancpain has a



privileged relationship with starred chefs such as Joël Robuchon, Daniel Humm and Claude Bosi. Celebrating this shared philosophy, the Manufacture and Joël Robuchon have combined forces to promote their respective arts and the values that they share through events in Europe and elsewhere in the world.

Because the discovery of watchmaking knowhow is connected to an irreproachable reception and quality of service, Blancpain is also involved with the greatest hotel institutions in the world, such as Relais & Châteaux and the Leading Hotels of the World. In this respect, 2014 was synonymous with a new boom thanks to an exclusive agreement with the Relais & Châteaux establishments. Announced on the occasion of their 60th anniversary, this partnership is intended to bring clients and guests from the two *Maisons* together around a shared passion.

Also partner to the Leading Hotels of the World since 2005, Blancpain rewards the best establishments in the world and their exceptional personalities each year.

GRAND PRIX D'HORLOGERIE DE GENÈVE

Blancpain was proud to see its watchmakers' work rewarded in 2014 with the Grand Prix d'Horlogerie de Genève. The prize in the Ladies' Watch category was awarded to a new watch called the Women Heure Décentrée Seconde Rétrograde. The jury noted the technical and aesthetic characteristics of this watchmaking complication, which was developed especially for women. This distinction recalls the award won by the Manufacture in the same category at the competition's first edition in 2001.

Glashütte
ORIGINAL

www.glashuette-original.com



MORE THAN EVER, A TRUE MANUFACTURE

as well as on the creation of new space to enable the recruitment of additional specialists. Overall, various measures contributed to a one-third increase in the production area, an expansion that benefits departments involved in intense manufacturing activities such as assembly, polishing or watch finishing.

At the end of the building work, the Saxon manufacture invited international journalists to discover its modernized educational trail and provided a glimpse of its new premises.

CREATION

THE NEW CALIBER 37 FOR CHRONOGRAPHS

This year, Glashütte Original presented an integrated chronograph at Baselworld, based on a completely new design. After three years of development, the Caliber 37 celebrated its debut by presenting two exceptional models: the elegant Senator Chronograph Panorama Date and the sporty Seventies Chronograph Panorama Date. This chronograph caliber was designed according to the highest standards of functionality and daily practicality. Its compact, completely integrated construction makes it a reliable, attractive companion.

With a 4 Hz frequency, this automatic movement made in the manufacture's workshops guarantees maximum functionality, thanks to its design focused on efficiency and compactness. This approach is clearly illustrated by the one-piece construction of the switch lever in this movement, which sets it apart from earlier versions. The innovative movement thus guarantees the greatest possible degree of reliability while reducing the probability of torque errors or other functional problems.

TRENDS

GLASHÜTTE ORIGINAL PERFECTLY POSITIONED FOR THE FUTURE

The refurbishment and modernization undertaken in Glashütte (Saxony) at the headquarters of the Glashütte Original manufacture, was completed at the end of May 2014 after more than 15 months of construction. The end of the work represented the achievement of a range of measures decided upon by Swatch Group to progressively increase the German brand's production capacity. This was a necessary milestone that was required to meet the growing international demand for Glashütte Original's exclusive timepieces.

During the work, the focus was on the optimization of technological procedures implemented in the manufacturing process,



PANOMATICINVERSE

Successfully launched in 2008, the PanoInverse was the first timepiece made by the manufacture to exhibit the inner beauty of its mechanism. The balance-cock could thus be seen through the back of the watch for the first time. The PanoMaticInverse, launched at Baselworld 2014, continues in this vein and is presented with the new Caliber 91-02, a highly precise automatic movement with a 42-hour power reserve.

PRESENCE

EXTENSION OF THE BERLINALE PARTNERSHIP

For the fourth year of its partnership, Glashütte Original once again enjoyed a productive collaboration with the Berlinale. The enormous attendance at the festival was reflected in the number of guests welcomed to the Glashütte Original lounge, whose magnificent view and refined atmosphere made a big impression on guests. The "Him & Her" exhibition also generated great admiration. In addition to the *Perspektive Deutsches Kino* section, the brand supported the Retrospective section for the first time in 2014.

GLASHÜTTE ORIGINAL MUSIC FESTIVAL PRIZE AWARDED TO A VIOLIN VIRTUOSO

The exceptional artist Hilary Hahn won the Glashütte Original Music Festival Award at the festival's eleventh edition. On June 4th, Yann Gamard, President of Glashütte Original and Jan Vogler, Director of the Dresden Music Festival, presented her with the distinction at a concert given by the Frankfurt Radio Symphony Orchestra conducted by Paavo Järvi. During this event, which was warmly acclaimed by the public, the virtuoso

soloist performed the Brahms violin concerto. The 25000 euro prize was awarded to Ms. Hahn for "the burning, uncompromising intensity of her playing, which is an inspiration to many young musicians."

THE ART OF THE CHRONOGRAPH TRAVELLING EXHIBITION

After the official presentation of its new chronographs at Baselworld, the manufacture started to introduce its new timepieces to the market in the autumn. The roll-out was accompanied by a series of events that kicked off at the Glashütte Original boutique in Dresden. Following a stopover in Stuttgart, two additional events were held in the United States. The manufacture unveiled its interactive exhibition at the New Museum of Contemporary Art in New York and offered this fascinating journey into the world of the art of Glashütte watchmaking to clients of the Tourbillon boutique in Chicago for a week. In addition, the launches were accompanied by a marketing campaign on the brand's website and Facebook page.

INAUGURATION OF NEW BOUTIQUES IN SHANGHAI AND TOKYO

Shortly before the end of the year, Glashütte Original opened its second boutique on Nanjing Road West in Shanghai. A few days later, the brand presented its freshly renovated boutique at the Nicolas G. Hayek Center in Tokyo to a press gathering on site, as well as to an exclusive gathering of VIP guests. The design of these two boutiques reflects the clarity, functionality, authenticity and elegance, which represent the signature of Glashütte Original. Interactive presentations and innovative elements thus enable visitors to the two cities to be part of the action and to experience German engineering and Saxon watchmaking craft.

J*
D
JAQUET DROZ
SWISS WATCHMAKER SINCE 1738

www.jaquet-droz.com



THE ART OF WONDERMENT

TRENDS

JAQUET DROZ MAKES THE STARS SHINE

Excellence and discipline in movement describe the perfection of the vision of Maurice BÉjart ballet, just as they do when it comes to Jaquet Droz watchmaking. In 2014, thanks to its partnership with the BÉjart Ballet Lausanne, Jaquet Droz held its guests spellbound at more than 40 performances organized across the world. Underpinning this association, two pieces inspired by the world of dance were launched in Tokyo in November at a press conference held at the Nicolas G. Hayek Center, followed by a performance of Beethoven's Ninth Symphony.

JAQUET DROZ ROOTED IN MODERNITY, MARRIED TO TRADITION

By incorporating a silicon balance-spring into the escapement of its movement and revising its aesthetics, Jaquet Droz wrote a new chapter in the history of the Grande Seconde. The dial of the Grande Seconde Quantième Ivory Enamel has double enameling providing impressive depth of field and accentuating the great balance between the two counters which create the "8", the brand's lucky number.

JAQUET DROZ REVIVES HISTORY

The brand offered a new lease on life to a Jaquet Droz movement dating from 1780, for which the restoration and creation of the decoration required nearly a year's work. Perpetuating the genius of its creator, the Museum pocket watch is inspired by the wonders he bequeathed and unites all the resources of the watchmakers and the Jaquet Droz Ateliers d'Art.



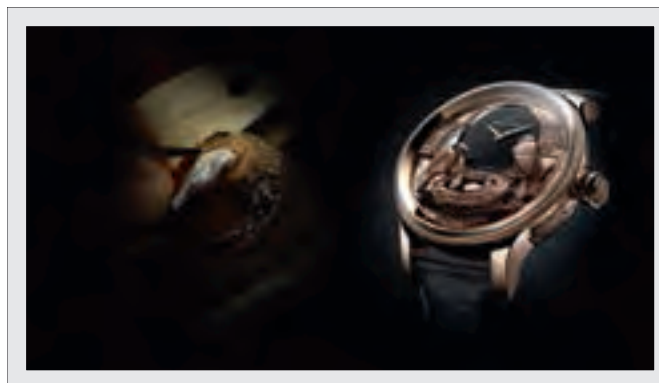

CREATION

BIRD REPEATER FULLY ENGRAVED

This masterpiece pays tribute to the quest for excellence of Jaquet-Droz, both a man of taste and a great watchmaker. The brand's engravers and painters have given birth to the subtleties of the red gold dial: the depth of the plumage, the perfect proportions, and the delicacy of the blades of grass composing the nest all bring unparalleled realism to the scene, in which no less than eight different animations have been orchestrated.

GRANDE SECONDE QUANTIÈME IVORY ENAMEL

True to its values of mechanical and decorative standards, Jaquet Droz once again gives pride of place to *evolution* – both technical and aesthetic – rather than *revolution*. Thus the movement of the Grande Seconde Quantième Ivory Enamel is largely made of silicon and enhanced with a fan-shaped Côtes de Genève pattern emphasizing the brand's identity. The dial has also evolved and now features double enameling.

GRANDE SECONDE SW CÔTES DE GENÈVE

The sporty and elegant Grande Seconde SW reflects the minimalist style of Jaquet Droz. Each model – anthracite grey, light grey or blue – brings additional character to the person wearing it. The Côtes de Genève décor on the dial provides this timepiece with an even more luxurious allure.

LADY 8 SHINY

The Lady 8 Shiny captivates with its poetic, sensual curves, while its white gold dial set with diamonds reveals a magnificent canvas. In a vivid demonstration of the exceptional know-how of its jewelry artisans, Jaquet Droz imbues this timepiece with a touch of daring: a mobile "pearl" made of diamonds at the top, exuding an irresistible invitation to touch.

THE SIGNING MACHINE

This year, Jaquet Droz also created amazement with the Signing Machine. This automaton used the historical technique of XXS-sized cams. The size of this miniature wonder is therefore in line with that most emblematic of contemporary objects: the smartphone. It perfectly reproduces the signature of the owner, a performance that may be admired through a transparent window revealing the mechanism and, in an age of digital triumph, affirms the unique, magical beauty of the exceptional mechanics made by Jaquet Droz.



PRESENCE

TRUE TO THE SPIRIT OF ITS CREATOR, JAQUET DROZ TRAVELS THE WORLD

RUSSIA, SWITZERLAND, MACAU, THE UNITED STATES...

Divided into five chapters, an exceptional traveling exhibition provided an opportunity to understand all the facets of Swiss watchmaking and the manner in which its heritage remains perfectly preserved today. Visitors were able to travel through time, from historical pieces of the 18th century to contemporary creations: automatons, creations from the Ateliers d'Art and birds in all their forms that created never-ending wonderment.

... MIDDLE EAST, JAPAN, AZERBAIJAN When artisans meet their greatest admirers, powerful emotions are stirred. During sessions with a select few, craftsmen demonstrated enamel-painting techniques and offered clients a chance to paint their own dials. And the Jaquet Droz enchantment once again worked its magic.





www.longines.com



THE YEAR OF THE HORSE, A LONGINES YEAR

TRENDS

In 2014, Longines continued its growth across the markets. On the occasion of the Chinese calendar's Year of the Horse, the brand furthered its commitment to the equestrian world and presented several pieces demonstrating its close links with this environment.

At Baselworld, Longines celebrated the 60th anniversary of its Conquest line and launched The Longines Elegant Collection. Throughout the year, the brand presented a series of re-editions that enhanced its Heritage line.

Partner to the greatest flat races, Longines signed new partnership agreements with famous equestrian competitions. The brand also organized the second edition of the Longines Ladies Awards and for the first time, was present at the Longines World Cup™ Jumping finals. True to its values, Longines also continued its commitment to young athletes in equestrian sports, tennis and downhill skiing.

CREATION

In 2014, Longines presented timepieces that demonstrated the rich history of the brand and remained true to its values of elegance, performance and tradition.

CONQUEST HERITAGE 1954–2014

To celebrate the 60th anniversary of its Conquest brand, Longines presented the Conquest Heritage 1954–2014 models, directly inspired by the very first Conquest watches. A medallion made of gold and enamel, similar to those of the original timepieces, adorns the bottom of these commemorative watches.

LONGINES EQUESTRIAN LÉPINE

Launched to commemorate the Year of the Horse, this pocket watch in rose gold reflects Longines's passion for equestrian sports. The back of this exceptional piece is adorned with a horse jumping an obstacle and its inspiration was drawn from the metal Lépine pocket watch dating from 1927, and kept at the Longines Museum in Saint-Imier (BE).

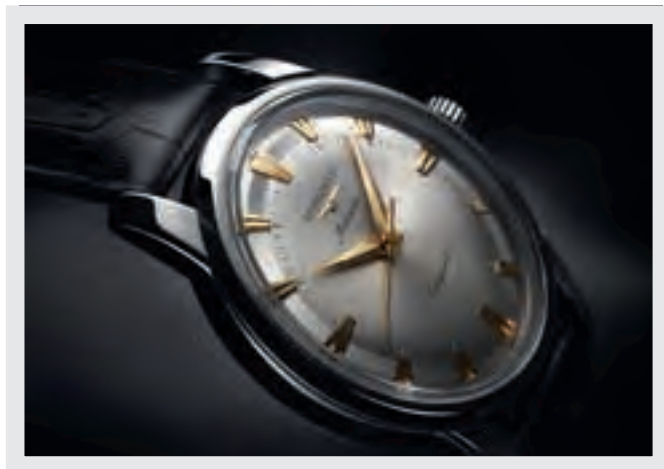

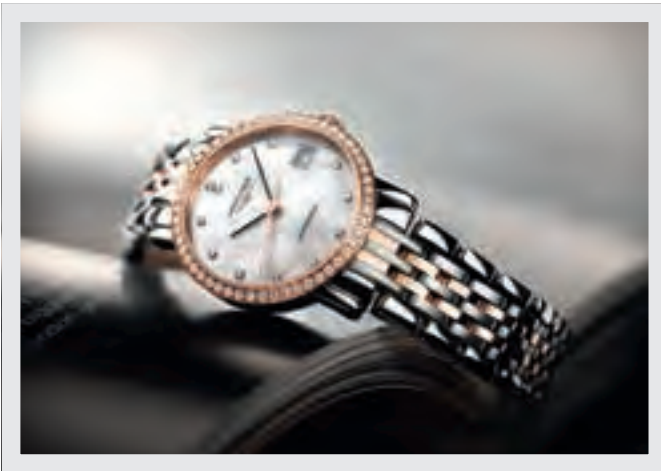
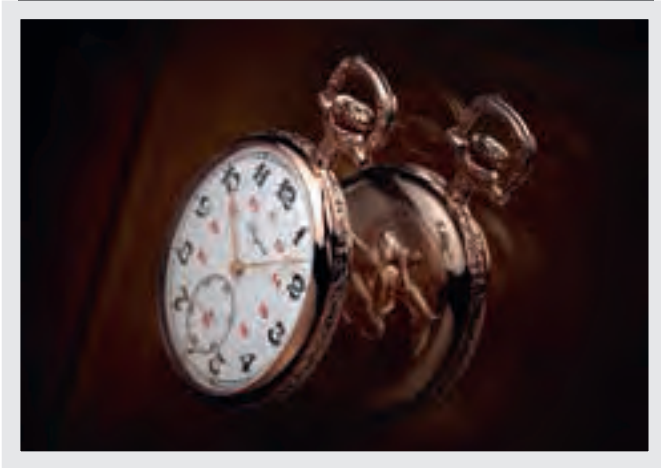

CONQUEST 1/100TH HORSE RACING

This line is a response to the needs of professional athletes and sports fans with, among other things, a function to measure multiple intermediate or 'split' times and a display of a hundredth of a second using a separate hand. With this model, Longines continues its longstanding tradition as a timekeeper for equestrian sports and pays tribute to all fans of flat racing.

THE LONGINES ELEGANT COLLECTION

Elegance, Longines's flagship value, inspired the creation of The Longines Elegant Collection, models launched in 2014 that perfectly represent the classicism and understatement inherent to the brand. Equipped with mechanical movements, they are available in three sizes and offer a wide range of dials, each presenting its own definition of elegance.

PRESENCE

BOUTIQUES

In 2014, Longines continued to strengthen its international presence, notably with the inauguration of its largest boutique in the world in Hong Kong, attended by its Ambassador of Elegance, Aaron Kwok.

NEW LONGINES AMBASSADOR OF ELEGANCE PRESENTED IN SHANGHAI

During a media conference in Shanghai, Longines presented its new Ambassador of Elegance, actor Eddie Peng. The innate class and charisma of this great Asian star perfectly correspond to the values that the brand has always promoted.

EQUESTRIAN SPORTS

Longines has woven close ties with equestrian sports for more than a century and today its involvement includes endurance, show jumping and flat racing.

In the world of flat racing, Longines has become the Official Partner, Official Timekeeper and Official Watch of the Japan Cup in association with Longines, as well as at the Breeders' Cup World Championships in the United States and the Chengdu Dubai International Cup. Present for the first time as Official Timekeeper and Official Watch of the Longines Queen Elizabeth Stakes in Australia, Longines invited its Elegance Ambassador, actor Simon Baker, to the event. In the context of his partnership with the International Federation of Horseracing Authorities (FIAH), Longines for the first time awarded the Longines World's Best Jockey prize to Ryan L. Moore (United Kingdom) and honored Orfevre, which placed joint third in the Longines ranking of the world's best race horses. Open to young jockeys, the Longines Future Racing Stars event was run during the Prix de Diane at Chantilly.

The day before, the brand had organized the second edition of the Longines Ladies Awards. Presided over by Longines Ambassador of Elegance, Kate Winslet, the jury rewarded Bo Derek, Criquette Head-Maarek, Jing Li and Sylvie Robert for their commitment to the equestrian world.

In the realm of show jumping, Longines officiated as partner in the role of Official Timekeeper of the Longines FEI World Cup™ Jumping, whose final took place in Lyon and was attended by the brand for the first time. Ambassador of Elegance Jane Richard took part in the first Longines Los Angeles Masters. In 2014, the number of legs of the Longines Global Champions Tour was increased to 14, with exceptional destinations such as Paris where the leg took place in front of the Eiffel Tower, and Shanghai,

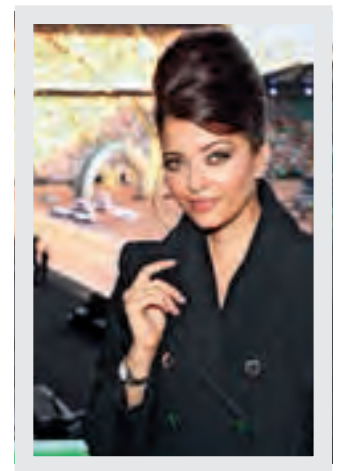
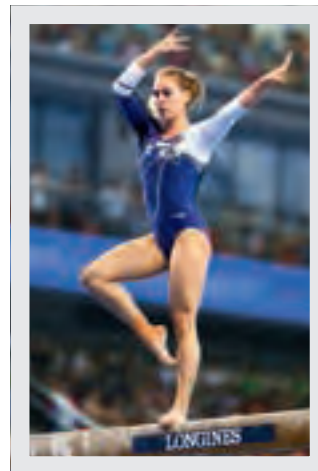

which offered international riders the first opportunity to compete in continental China.

TENNIS

Partner and Official Timekeeper of the Roland-Garros (French Open) tournament, Longines once again organized the Longines Future Tennis Aces. This fifth edition brought together 16 international players under the age of 13. In an exceptional setting, at the foot of the Eiffel Tower, Federica Rossi (Italy) won against Daria Frayman (Russia). The finalists then took part in an exhibition match with two former professional tennis players, tournament patron Marion Bartoli and Nathalie Dechy.

ALPINE SKIING

At the opening of the Alpine skiing season in Sölden, Longines introduced its new Ambassador of Elegance, the American skier Mikaela Shiffrin. Under the patronage of the 2013 world champion and holder of two Crystal Globes in Slalom, the Longines Future Ski Champions provided an opportunity for fourteen young female skiers under the age of 13 to battle it out during a giant slalom in two legs on the official race course at Val d'Isère. Official Timekeeper of the FIS Alpine Skiing World Cup, Longines also supports young hopes in the "great white circus". At the end of the 2013–2014 season in Lenzerheide (GR), the brand awarded the Longines Rising Ski Stars to the two best athletes under the age of 21 for women and under the age of 23 for men. Mikaela Shiffrin and Alexis Pinturault won this prize for the second year in a row.

GYMNASTICS

Gymnasts Yana Kudryavtseva (Russia) and Giulia Steingruber (Switzerland) joined the Longines Ambassadors of Elegance family, alongside the Chinese men's artistic gymnastics team. Official Partner and Timekeeper for the rhythmic and artistic gymnastics events for the International Gymnastics Federation for nearly 30 years, Longines attributed the Longines Prize for Elegance at the 2014 World Championships to Nanning (China) and to Izmir (Turkey). Kohei Uchimura (Japan) and Yao Jinnan (China) won the jury's hearts with their artistic performances, while Yana Kudryavtseva won every vote in rhythmic gymnastics.

ARCHERY

Longines renewed its commitment as Official Partner to the Archery World Cup and awarded the Longines Precision Prize to two classic archers, Brady Ellison (United States) and Aida Roman (Mexico) at the final in Lausanne.

COMMONWEALTH GAMES

Taking up a role that it held in 1962 in Perth, Australia, Longines took part as Official Partner, Official Chronometer and Official Watch of the Glasgow 2014 Commonwealth Games. The 20th edition presented 17 sports over 11 days of competition and Longines Ambassador of Elegance, Aishwarya Rai Bachchan, attended the opening ceremony of the event.

RADO
SWITZERLAND

www.rado.com



PIONEERING SPIRIT AND MATERIAL MASTERY

TRENDS

DUAL TIMER TACTILE TECHNOLOGY

Following on the groundbreaking introduction of touch technology in a high-tech ceramic watch, Rado presented the HyperChrome Ceramic Touch Dual Timer. With a main dial displaying the time at the current location and the small dial at 6 o'clock showing the second time zone, this is a watch made for globetrotters.

The touch technology allows the watch to be activated in two simple steps, after which time can be turned back or made to fly by in a single stroke. An additional function allows the user to "swap" the two time-zones, a very practical feature for frequent travelers and a spectacular sight to behold when this function is engaged and the hands on the two dials can be followed as they rotate until they reach their respective positions.

GREY IS THE NEW BLACK

Every year Rado consolidates its status as "master of materials" in the watch industry by presenting a new, innovative variation on high-tech ceramic. This time it was grey ceramic's turn. A particularly challenging color to achieve with stability, grey ceramic with a matt or glossy finish graced the monobloc cases of the new HyperChrome Ceramic Touch Dual Timer.

Rado also extended the use of its extraordinary plasma high-tech ceramic. A process patented by Swatch Group, this amazing form of modern alchemy transforms the molecular structure of white high-tech ceramic, giving it a warm grey metallic sheen that is unique in the watchmaking world. The Rado HyperChrome and DiaMaster collections showed this material off to perfection.

UNDERSTATED LUXURY IN PRESTIGIOUS LOCATIONS

Building on its strong retail activities in 2013, Rado opened another significant number of boutiques during 2014 in some of the world's premier shopping locations and most prestigious malls in the world. Particularly noteworthy were new flagship stores in Singapore at Marina Bay Sands as well as in Hong Kong and Mumbai.



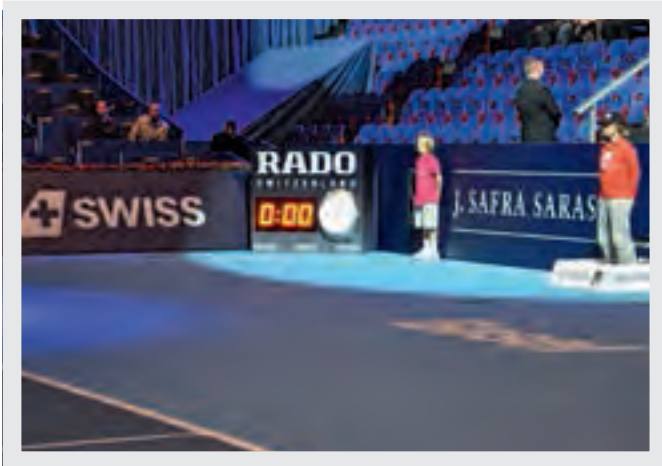

ADVANTAGE RADO

In the world of tennis Rado consolidated its presence at 14 tournaments across all continents. WTA tennis star Agnieszka Radwańska from Poland joined Rado's team of star ambassadors in the sport.

RADO DIAMASTER AUTOMATIC SKELETON

Subtle, minimalistic and chic are the key words when it comes to the design of these simple, pared-down watches. Rado continues its tradition of combining high-tech materials with the open-dial view of a skeletonized mechanical movement. Tradition and futuristic materials truly come together in these timepieces.

CREATION

RADO HYPERCHROME CERAMIC TOUCH DUAL TIMER

This is the perfect timepiece for the person who travels: lightweight, hypoallergenic and scratch-resistant, it can stay on the wrist whatever happens. In full high-tech ceramic, it can even go through airport security.

The main time display is set by activating the watch using sensors at the top of the case, the small dial using the ones at the bottom. Sliding the finger along the left hand side of the case can make hours fly by and on the right hand side, the minutes. The minutes of the two time zones are synchronized to guarantee accuracy and both minute hands move during time setting on the main dial.

RADO DIAMASTER AUTOMATIC CHRONOGRAPH

A resolutely modern design for a Rado classic, the new DiaMaster collection was introduced with the Automatic Chronograph XXL as its flag-bearer. A striking look with an imposing size that cannot be ignored on the wrist, the DiaMaster also presented another first for the brand with its 5-link bracelets in full ceramic. Designed to deliver the ultimate in wearer comfort, these intricate bracelets are made of up to 100 pieces or more that must be carefully assembled to achieve a seamless look.

PRESENCE

TENNIS IS OUR PASSION

Rado corner clocks and branding were visible on court at 14 major tournaments in the USA, Europe, Asia and the Middle East. Highlights of the year included Rado's presence at the Swiss Indoors, Basel for the first time. One of the largest indoor tournaments on the tour, the Swiss Indoors saw Rado take its place on Centre Court with its renowned corner clocks as large crowds cheered on local tennis heroes and international stars. The Kremlin Cup by Bank of Moscow went from strength to strength with local hero and young friend of the brand Karen Khachanov showing off his potential to become a strong contender for the tennis elite.

The Rakuten Open in Tokyo proved that tennis fans are prepared to face the toughest conditions to watch their heroes as a hurricane closed in on the capital city but did not manage to discourage spectators, who packed the stalls to witness every minute of the finals weekend.

The strong presence at tournaments was supported by an integrated marketing package including CNN and Eurosport, with star presenters Pat Cash and Mats Wilander often attending the brand's events to entertain guests and media with their insights into the game and backstage stories on the tennis tour.

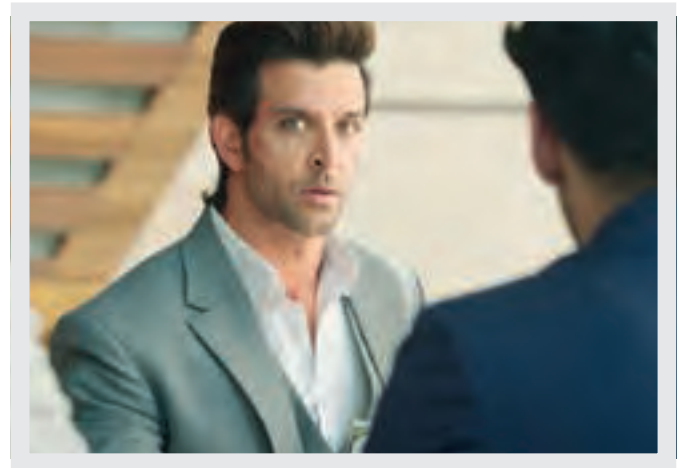

DESIGN IS OUR DNA

Rado continued its involvement in design platforms such as Paris Design Week and Vienna Design Week. It also strengthened its presence in the design field by becoming Official Partner of the World Design Capital® in Cape Town, South Africa. As part of its activation program, Rado ran a special Rado Star Prize in South Africa dedicated to the theme of social design, giving talented local designers a platform to express their work and promote their ideas.

AMBASSADORS

Following an intense courtship of several months, Chinese-born superstar Tang Wei became the latest addition to Rado's international roster of A-level brand ambassadors. Tang Wei impressed everyone with her grace, spirit and intelligence and happens to have been born in the same year that Rado first entered the Chinese market, 1979. The cooperation was announced at a lavish event in Shanghai and cemented with a glamorous advertising campaign photo-shoot in Hong Kong.

Bollywood megastar Hrithik Roshan was again the hero of a brand new TV commercial for Rado. Hrithik got the opportunity to show off his action-hero credentials by chasing a thief through a 5-star hotel (sliding through a busy kitchen, down an elevator shaft and into an air conditioning duct with his trusty plasma DiaMaster) all the way to a... surprise party! The thief turned out to be our very own Lisa Ray in an unexpected and uplifting finale that allowed us to put our two ambassadors on screen together for the first time in years.

Multitalented Russian ambassador Renata Litvinova was the star of a glamorous Esenza Ceramic Touch launch event in Moscow. True to herself, Renata decided to do much more than simply be present at the event and realized a very special and exclusive photo-art project celebrating her relationship with Rado.

Agnieszka Radwańska celebrated her new relationship with the brand by participating in a glitzy event held in her honor in Warsaw to present the HyperChrome collection to local media and VIPs. She was also on hand in New York to greet her fans at the Hour Passion store on the way to the Taste of Tennis event – a yearly gala bringing together top chefs and top tennis players to surprising and tasty results.

UNION
GLASHÜTTE/SA.

www.union-glashuette.com



GERMAN TRADITION AND INNOVATION

TRENDS

Union Glashütte was able to increase its production capacity significantly thanks to large investments made by Swatch Group in the Glashütte (Saxony) manufacturing facilities. These enabled the brand to meet the increased demand for its products in its primary markets of Germany and Austria. Union Glashütte was also launched in Russia, Dubai, the Netherlands and the Czech Republic, and it is also encouraging to report that the demand for its traditional German timepieces steadily increased in tourist destinations as well.

CREATION

BELISAR PILOT POWER RESERVE

The large Belisar Pilot Power Reserve combines a sporty look with maximum contrast. It brings together all the qualities of a contemporary pilot's watch with the elegant design of the Belisar collection. The large stainless-steel case with a diameter of 45 mm guarantees that the time is clearly visible, while the well-spaced hour and minute indices and distinctive white numerals provide maximum contrast against the dark dial. Super-LumiNova on the pointed hands and the indices ensures that the wearer can see the time even at night.



Union Glashütte – Official Partner of the SaReNi Camaro Racing Team



**OUR DRIVES: PRECISION,
PASSION AND PERFECTION**

The Belisar Chronograph shows the sporty side of our time. The black PVD coating, carbon dial and red accents provide a striking frame for the chronograph counter and date indicator, which are elegantly arranged in several dial windows. Thanks to its high-quality automatic movement, anti-reflective sapphire crystal on both faces, highly intricate skeletonised rotor and screw-on case-back with sapphire crystal, this watch can hold its own even on the world's toughest racetracks. A timepiece for German watchmaking enthusiasts - precise, timeless and beautiful.

BELISAR
CHRONOGRAPH

**UNION
GLASHÜTTE/SA.**
GERMAN ART WATCHMAKING – 1893

www.union-glashuette.com



BELISAR CHRONOGRAPH WITH MOON PHASE

Last year, Union Glashütte presented an especially high-quality and refined two-tone version of the Belisar Chronograph with moon phase. The bezel and the characteristic screw-down flanks are finished in 18K rose gold. In combination with the stainless steel case, these elements give this classic watch a thoroughly modern feel.

SIRONA BICOLOR

The popular Sirona ladies' collection now includes two new additions, the elegant designs of which reflect the current trend towards two-tone themes. The case on these watches combines 18K rose gold and stainless steel with the soft sparkle of eight diamonds on the dial to create an absolutely luxurious accessory.

PRESENCE

SARENI CAMARO RACING – GT MASTERS SERIES

This year, Union Glashütte entered into a partnership with the SaReNi Camaro racing team, which participated in all eight races of the ADAC GT Masters series. Prince Albert von Thurn und Taxis (gentleman racing driver) and Czech professional racing driver Tomaz Enge (former Formula 1 driver) shared the racing car's cockpit. Union Glashütte's distinctive branding was boldly emblazoned on the car and the drivers' suits and helmets. This was an ideal platform for Union Glashütte, a traditional brand from the German state of Saxony, to communicate its values to a motorsports-minded audience.

OLDTIMER CAR RALLIES – SACHSEN CLASSIC AND SILVRETTA CLASSIC

For the fifth time in a row, Union Glashütte acted as one of the main partners of the famous Sachsen Classic vintage car rally. Union Glashütte was ubiquitous at the rally, which was held in August. As in previous years, a limited-edition timepiece was launched to celebrate the Sachsen Classic. This year's was an 18K rose gold Noramis Chronograph, the production of which was limited to just 50 units. For the second time, Union Glashütte also acted as a main partner of the Silvretta Classic rally, which passes through vast swathes of Austria.

LAUNCH EVENT IN MOSCOW

In June, Union Glashütte presented itself to the Russian press at a major launch event in Moscow. The event was held in the city's vintage car museum, and visitors were given a tour of it following the official presentation of the German watchmaking brand. All the industry experts there were impressed by the brand's products and philosophy.



www.tissot.ch



STRONG INNOVATION BOTH IN PRODUCT AND IN RETAIL

TRENDS

- In 2014 Tissot enjoyed yet another year of positive growth.
- With a presence in 160 countries, Tissot has the largest worldwide retail network in the Swiss watchmaking industry, with 13000 points of sale, 3000 shop-in-shops and 230 monobrand boutiques. 2014 saw the opening of some stunning boutiques in prime locations in New York City (Fifth Avenue and Wall Street), Zurich (Bahnhofstrasse) and London (Oxford Street).
- This was an outstanding sporting year for Tissot, with increased involvement at top events around the world. Its timekeeping partnerships reflect the company's dynamic nature and dedication to precision and high performance. Highlights included acting as Official Timekeeper at the 17th Asian Games Incheon 2014 in South Korea and at the FIBA Basketball World Cup Spain 2014.
- Proud of its Swiss heritage and closely linked with the Swiss Alps, Tissot partnered with Glacier 3000 – Les Diablerets for the world's first suspension bridge to connect two mountain peaks, called "Peak Walk" by Tissot. The new Tissot global advertising campaign focuses on the company's Swissness. Emphasis is on the '+' in the Tissot logo, which not only mirrors the Swiss flag, synonymous with quality and reliability, but also indicates the multiple functions of each meticulously crafted watch.
- Tissot marked the introduction of the world's first tactile watch powered by solar energy by going live with a new website, t-touch.com. With its design inspiration rooted in the power of touch, it invites visitors to try out the Tissot T-Touch watches' tactile functionality on an impressive virtual world tour.
- Tissot revamped its YouTube channel, www.youtube.ch/tissot, which covers everything from Tissot products and heritage to sports. It also successfully increased its presence on social networking sites Facebook, Twitter and Instagram, driving more visitors to its pages on all three.





CREATION

Leading the way in innovation, Tissot launched the Tissot T-Touch Expert Solar – the world's first tactile watch powered by solar energy – with the slogan 'Tactile, Solar, Revolutionary'. This cutting-edge timepiece offers 20 functions, including weather forecast, altimeter and compass. The female counterpart, the Tissot T-Touch Lady Solar, features a mother-of-pearl dial.

Another watch in the limelight was the elegant Tissot T-Complication Chronometer, with its mechanical hand-wound movement, visible courtesy of the transparent caseback. This model has its roots in the Tissot T-Complication Collection, which attained first and second prize in the 'Classic – Enterprise' category of the famous International Timing Competition, the Concours International de Chronométrie, in 2013. The double win attests to the precision of Tissot products.

Always in fashion, gold featured in a number of new designs for 2014. The Tissot Glamorous – a luxurious ladies' watch in an elegant vintage design – has an oval 18K rose gold case enclosing a beautiful mother-of-pearl dial with Roman indices. Top Wesselton diamonds are optional and it comes in a variety of bracelet styles. The Tissot Vintage Powermatic 80 for gents is also based on an antique design, with distinctive Arabic or Roman numerals and an 18K yellow or rose gold case. The automatic movement with 80 hours of power reserve can be admired through the see-through caseback.



PRESENCE

A world first is cause for celebration and there were festivities around the globe to promote the Tissot T-Touch Expert Solar – the first solar-powered tactile watch. From June to September, the Cité du Temps in Geneva hosted a fascinating exhibition, Tissot: The Light of Time, charting the evolution from tactile technology to solar energy. Tissot also presented the Tissot T-Touch Expert Solar at a spectacular event in the prestigious National Museum of Science and Technology Leonardo da Vinci in Milan in September. The fitting venue housed an exhibition telling the story of the development of the solar tactile watch. Paris is often referred to as The City Lights so a huge illuminated billboard presenting the revolutionary product was very much at home on the Place de la Concorde, the capital's largest square.

Two breathtaking events in Asia captured guests' hearts and minds. On February 7 around 280 people gathered at the super-stylish Tokyo Contemporary Museum of Art for a night to remember. An exhibition featuring 36 historic Tissot timepieces, some on show outside Switzerland for the first time, stood proudly next to models from the current collection. This was complemented by a special silhouette dance and shadow performance by the famous Le Ombré company. The choreography portrayed the adventures and challenges of Tissot across the unknown since its foundation and how far it has come over the years. A few days later the spotlight was on Seoul, the next destination for the historic exhibition and also the launch pad for the Tissot Asian Games Collection.

In 2014, retail highlights included openings of several new Tissot boutiques in superb locations in major cities. In September, over 500 people flocked to the official opening of the first Tissot boutique in the USA at 666 Fifth Avenue, in the heart of New York City's shopping district. NBA star and Tissot brand



ambassador, Tony Parker, joined the celebrations. At the end of October, race car driver and Tissot ambassador Danica Patrick dropped by the Fifth Avenue shop for a meet-and-greet event with fans. Tissot was quick to add a second New York boutique, with the 45 Wall Street location opening its doors in November. A few days after the opening, Tony Parker came to the store to challenge fans to a basketball shooting competition and join Tissot President François Thiébaud for the official inauguration. Thousands of Christmas shoppers at 373 Oxford Street, London also had the chance to shop in a brand new Tissot boutique. Closer to home, Tissot celebrated the opening of its first boutique in Switzerland, on fashionable Bahnhofstrasse in Zurich. The sleek store occupies a prime position alongside the most prestigious fashion, luxury leather goods and watch and jewelry boutiques.

Official Timekeeper of FIBA since 2008, Tissot was ready for action at the FIBA Basketball World Cup Spain 2014, which took place from August 30 to September 14. In an exhilarating final, the USA team beat Serbia for its fifth world crown. François Thiébaud awarded the Most Valuable Player of the tournament to USA guard Kyrie Irving.

Tissot was proud to be the Official Timekeeper of the 17th Asian Games Incheon 2014, where 13000 athletes competed in 36 disciplines at 49 venues from September 19th to October 4th. Tissot's involvement also included the presentation of a limited edition watch and Tissot World Record Award to each of the 14 world record breakers, plus a special gala attended by a number of celebrities.

Before the last race of the 2014 MotoGP season in Valencia, Tissot held an international press event to reveal the Tissot MotoGP Collection 2015. Tissot MotoGP ambassadors Nicky Hayden, Stefan Bradl and Thomas Lüthi received their personalized limited-edition watches, designed to reflect their personalities.

Calvin Klein

watches + jewelry

www.calvinklein.com



MODERN, MINIMAL, INSPIRING

TRENDS

In 2014 Calvin Klein watches + jewelry consolidated its new upgraded branding, from “ck Calvin Klein” to “Calvin Klein Platinum”, enhancing and aligning its positioning with the globally-recognized legacy of the Calvin Klein name and DNA. In order to reinforce and celebrate this rebranding, a new campaign was shot in California by leading photographer Mario Sorrenti. It featured model Edita Vilkeviciute, along with renowned male model Matthew Terry. Sorrenti played with the light and shadows on their bodies, creating a sensual and sophisticated mood throughout all the imagery. The campaign illustrates in a warm, pure and strongly emotional way the brand’s sophisticated sensuality, so typical of Calvin Klein.

Calvin Klein watches + jewelry, in parallel with this new positioning, also improved its distribution network impressively. As a result, the brand has expanded its qualitative distribution in all regions and increased market share further by implementing a strong marketing strategy.

Great brand awareness and strong demand for watches and jewelry resulted in an excellent result in terms of visibility, with the company again successfully expanding its retail network in 2014. The quality of its presence on the markets was further emphasized and its distribution strengthened, mainly in the form of remarkable shop-in-shops in the most popular commercial areas. In particular, the shop-in-shops in China and Taiwan performed above all expectations and clearly demonstrated the brand’s vast potential.

2014 was also marked by the opening of a large number of significant freestanding stores in China, Australia and Malaysia.

In Europe, Calvin Klein watches + jewelry had a positive year despite a still-complex economic environment. The brand has played its cards right, developing its market share in most European countries.





CREATION

The 2014 collection was more adventurous and exciting, with a strong signature but always wearable and functional. It was creative and innovative both in terms of design and materials. The sensual advertising campaign highlighted the agile and feminine Calvin Klein body watch and jewelry for her and the sophisticated, essential Calvin Klein time unisex style.

The iconic and sophisticated Calvin Klein bold, first launched in 2007, was redesigned and celebrated the refined design of the Calvin Klein brand. For its new collection, launched at Baselworld, Calvin Klein watches + jewelry and Calvin Klein color introduced for the first time watches made of aluminum and presented in an extensive range of colors.

PRESENCE

Calvin Klein watches + jewelry introduced the new 2014 collection in Shanghai at the Hwas Gallery. The presentation also featured two models, mirroring the new sensual and sophisticated spring 2014 advertising campaign. The preview was followed by an intimate dinner at Unico, hosted by Laura Burdese, President of Calvin Klein watches + jewelry, and Ulrich Grimm, Creative Director of Calvin Klein's Men's & Women's Shoes & Accessories. The event was attended by special guest Chinese model and actress Angelababy, as well as editors and other industry notables.

At Baselworld, Calvin Klein watches + jewelry hosted a special, invitation-only dinner at the Kunstmuseum Basel, the city's renowned center for fine art. At the dinner, the brand announced its partnership with Istituto Europeo di Design (IED) in Milan, Donghua University in Shanghai and the Fashion Institute of Technology (FIT) in New York City to host a watch and jewelry design competition for their students. Judges for the design competition included Laura Burdese, Ulrich Grimm and popular bloggers Chiara Ferragni, Hanneli Mustaparta and Nicole Warne – all of whom were in attendance at the event.



BALMAIN
swiss watches

www.balmain.com



THE BALMAIN SPIRIT: SUBTLE AND APPEALING

TRENDS

Despite the somewhat uncertain economic situation that prevailed in 2014, Balmain achieved stable sales volumes, notably due to the use of significant marketing activities that enabled the brand to maintain its presence in its principal markets.

China and the Middle East were particularly affected by the difficult economic climate but nevertheless remained key markets for Balmain. The brand continued its expansion strategy in Hong Kong, where it recorded a strong increase in sales. In addition, the brand's client portfolio enjoyed pleasing stability in Europe, an area in which Switzerland, Russia and Benelux represent its preferred markets.

In order to reinforce its brand image, which – in its mid-range segment – blends elegance, femininity and daring with quality and Swiss Made, Balmain reduced the number of models presented at Baselworld 2014. This new approach was very well

received by all its clients. Synonymous with affordable luxury, all the brand's timepieces incorporate both tried-and-tested techniques and a design as subtle as it is appealing, combining the best of both worlds today and for the long term.

CREATION

MAESTRIA ROUND AUTOMATIC PAIR WATCHES – IDENTICAL MODELS FOR HIM AND HER

Couple watches achieved genuine success, notably in China, and in order to enable those in love to experience an even more complete sense of 'fusion', Balmain offered its Maestria Round Automatic in several models rigorously identical except for the different sizes for men and women. In this way, the outward expressions of sharing and an exchange of eternal vows can be seen not only in the wedding ring, but also on the wrist.

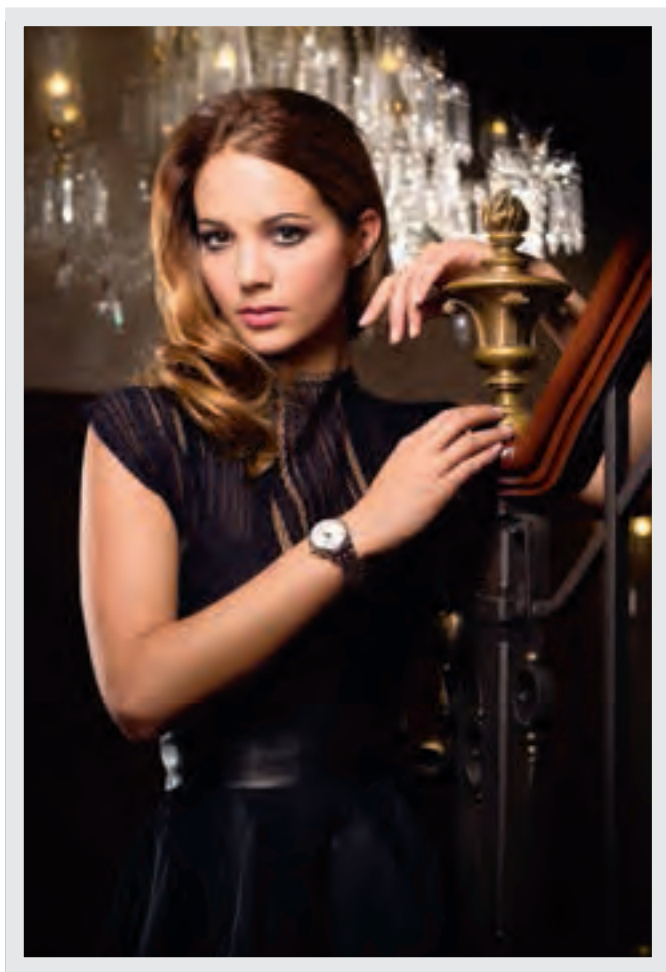

DREAM CHRONO LADY – A WATCH TO FEEL LIKE A QUEEN

Balmain specially created the Dream Chrono Lady for the winner of the Miss Switzerland beauty contest. A veritable crown on the wrist, with its 68 diamonds, this chronograph symbolizes elegance, charm, femininity, sensuality, daring and determination.

BALMAZING II – JOY WITH EVERY GLANCE

Both attractive and captivating, Balmazing II captures hearts from the first glance, with the elegant curves of the arabesque – Balmain’s exclusive motif – touching even the hardest hearts. Models from this collection express the inventive character and style of an adventure born in the world of Parisian fashion and enhanced by masters of Swiss watchmaking.

LA VELA II – THE CLASS OF A THOROUGHbred, THE LOOKS OF A WINNER

With its slim design, the La Vela II models transform a feminine wrist into a graceful fashion display. An elongated, slightly curved rectangle, often emphasized with a row of diamonds, the case measures just 16.7 millimeters wide by 28.4 long, and not more than 6.15 millimeters thick at any point!



PRESENCE

In 2014, Balmain organized various events in its most strategic markets. In India, for example, a training program bringing together all the brand’s national partners was organized at Vivanta by Taj in Mumbai, with diplomas awarded to participants by famous French-Indian model and actress, Shazah Padamsee. In Kuwait, a VIP cocktail was held at the Tik Tok Showroom with the Behbehani Group, attended by Balmain ambassador, Dominique Rinderknecht who wore a Beleganza Chrono Lady for the occasion. Miss Switzerland 2013 also attended an event organized by the brand for the media and international clientele during Baselworld.

Balmain has consistently lit up fashion runways, so it is not surprising that the brand has been the privileged partner to the Miss Switzerland pageant since 2005. In 2014, the voting took place on October 11th in Berne on the Bundesplatz. Nominated the most beautiful woman in the country, Laetitia Guarino now wears the Dream Chrono Lady on her wrist and, a symbol of elegance and modernity, represents the Balmain values that she will strive to promote for a one-year period.

CERTINA
SWISS WATCHES SINCE 1884

www.certina.com



PRECISION AND INNOVATION

TRENDS

2014 was an innovative year in terms of technology and materials. All Certina quartz watches launched this year were fitted with the new ETA PreciDrive™ movement, thus making them as precise as chronometers. The DS Podium GMT Aluminium attracted a lot of attention in the run-up to the Christmas period. Certina was able to continue growing and significantly increased its share in all key European markets. The brand's high-end positioning and its exceptional price/performance ratio steadily developed its customer base. Certina also enjoyed tremendous success in Russia, which is one of the world's largest watch markets. Certina's increased presence in the Middle East through setting up larger numbers of shop-in-shop stands in Rivoli Group stores bore fruit as well.

CREATION

DS PODIUM GMT ALUMINIUM

The DS Podium GMT Aluminium combines the very best of original design and state-of-the-art technology. The aluminum case is not just extremely lightweight – it also opens up new and captivating design possibilities. An innovative coating technique (anodization) makes it possible to create any desired color tone and guarantees extremely high scratch resistance. The DS Podium GMT Aluminium features an ETA PreciDrive™ quartz movement, which is as precise as a chronometer, as well as a second time zone (GMT) and a 12-hour chronograph.

DS PODIUM BIG SIZE CHRONOGRAPH

The latest addition to the DS Podium line follows the product range's characteristically bold design. The DS Podium Big Size has a 316L stainless-steel case with a diameter of 44 mm. It is also fitted with an ETA PreciDrive™ quartz movement with a chronograph that is accurate to 1/100th of a second. This quartz movement has a guaranteed precision of +/-10 seconds per year, making it as accurate as a chronometer.

DS DREAM

Certina's latest ladies' watch combines elegant design with exquisite contemporary workmanship. The 38-mm-diameter model is available in a number of stylish designs, including one that is made purely from polished stainless steel and one that features a rose-gold-colored PVD coating. A further design boasting a bezel adorned with 120 diamonds adds a touch of luxury to the line.



PRESENCE

HOMAGE TO CERTINA'S TEN-YEAR PARTNERSHIP WITH THE SAUBER F1 TEAM

Certina launched a special edition DS-2 chronograph, with production limited to just 2014 units, to mark ten years of an important and esteemed partnership with the Sauber F1 Team. On September 4th, at the launch event in the Sauber hospitality suite at the Italian Grand Prix in Monza, Certina President Adrian Bosshard presented Peter Sauber and team drivers Estéban Gutiérrez, Adrian Sutil and Guido Van der Garde each with one of these exclusive chronographs before the international press. Throughout the Grand Prix weekend, the Sauber F1 Team racing cars also displayed prominent special Certina anniversary branding.

PRESS CONFERENCE WITH BIATHLETE OLE EINAR BJØRNDALEN IN MOSCOW

On 11 April 2014, in the company of the outstanding Norwegian biathlete himself, Certina launched the Certina DS – Limited Edition – Ole Einar Bjørndalen, at a press conference in Moscow. This limited edition timepiece, of which only 2014 units will be produced, was created in honor of Bjørndalen's distinguished career. Bjørndalen is the world's most successful biathlete to date and has been an official Certina ambassador since 2011.

CERTINA FORMULA 1 ROADSHOW WITH ADRIAN SUTIL, HOUR PASSION – OXFORD STREET, LONDON

In the run-up to the British Grand Prix at Silverstone, Certina organized a big Formula 1 roadshow at the Hour Passion boutique on Oxford Street in London. The large, extra-special window display and Formula 1 simulator attracted scores of visitors. The roadshow was opened on July 2nd with special guest

Sauber F1 Team driver Adrian Sutil. Many motorsport fans had the opportunity to meet the Sauber driver, race against him in the Formula 1 simulator and witness the official launch of the DS Eagle in his company.



MIDO
SWISS WATCHES SINCE 1918

www.mido.ch



A COMBINATION OF TRADITION AND AUTOMATIC

TRENDS

2014 proved to be very fruitful for Mido, which experienced a new page in its history, especially marked by the celebration of the 80th anniversary of the Multifort collection, the launch of two calibers and the achievement of a record new reporting year.

Mido recorded strong growth in every region of the world where it is represented, notably in China where it experienced enormous growth and gained significant market share.

True to its philosophy, Mido continued to focus on tradition by placing its trust in its historic collections which, renowned for their timeless character and excellent quality-price ratio, were further enriched with new watches combining reliability and aesthetic appeal.

CREATION

MULTIFORT

To celebrate the 80th anniversary of the Multifort collection, Mido launched several timepieces synonymous with robustness. A watch of timeless elegance and a tribute to a Multifort model dating back to 1940, the Multifort Limited Edition Heritage was produced as a 999-piece limited edition. Innovation and precision are the keynotes of the Multifort Chronograph Caliber 60, a model developed for the most enduring athletes. Thanks to a new movement offering up to 60 hours of power reserve; water-resistant to 20 bar, this watch ensures perfect readability, both under water and at night, thanks to the use of large luminescent details on the dial and rotating flange. A new GMT edition and models combining titanium and rubber were also added to the Multifort collection in 2014.

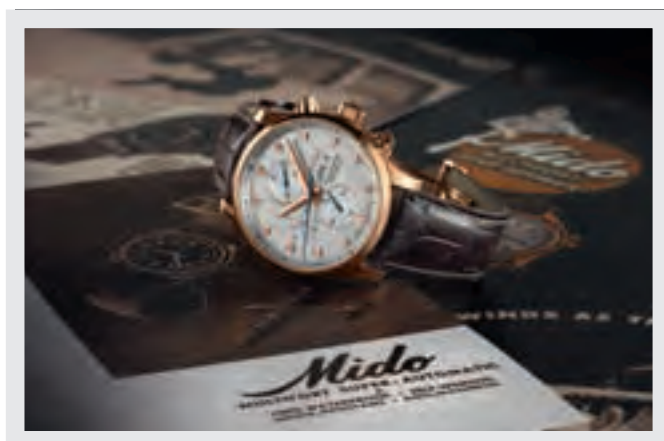

COMMANDER

Emblematic of Mido's know-how since 1959, the Commander collection was expanded with the Commander Caliber 80 Chronometer. This high-precision model is equipped with a state-of-the-art chronometer movement that is made according to the highest standards and offers double the standard autonomy, with up to 80 hours of power reserve. This new development thus represents the best in watchmaking innovation combined with a timeless design that has charmed unflinchingly for over half a century. It also demonstrates that Mido remains very committed to precision, since it continues to be the brand in its price segment offering the widest choice of chronometers certified by the Swiss Official Chronometer Testing Institute (COSC).

BARONCELLI

The Baroncelli models created in 2014 are synonymous with the harmony of their forms and elegance of their curves. The new Baroncelli Donna pays tribute to women, with its dainty curves and delicately juxtaposed materials such as diamonds, mother-of-pearl and pink PVD. The Baroncelli Small Seconds Diamond, sparkling with femininity, offers a new configuration, with an off-center seconds hand placed in a counter at 7 o'clock, enhanced by a dial adorned with 36 diamonds and whose center features a fine pattern of concentric circles.

ALL DIAL

The All Dial Limited Edition 1918 is a celebration of the year the Mido brand was founded. Like the Roman Coliseum that inspired it, this exceptional timepiece issued in a 1918-piece limited edition is a rare piece that will stand the test of time and retain its radiance.

PRESENCE

Mido is particularly proud to have signed the first agreement in its collaboration with the International Union of Architects and to be associated with the UIA 2014 Awards, some of the world's most important architectural distinctions. The brand honored the laureates of the different prizes awarded at the 25th World Congress on Architecture, held in Durban (South Africa) with watches from its collection, including two unique, specially dedicated models.

Consistent with its strategy, Mido's qualitative expansion continued in 2014 with the opening of a number of points of sale and four mono-brand boutiques.

The celebration of octogenarian Multifort, the launch of new Mido lines and the partnership with the International Union of Architects were highlighted through a number of events and activities, notably in Taiwan, Mexico and South Korea as well as in the United States and China.

www.hamiltonwatch.com

AMERICAN SPIRIT • SWISS PRECISION

TRENDS

Hamilton enjoyed another successful year with global growth in 2014. The highlights included the launch of a new advertising campaign, the development of new calibers with ETA and a leading role in *Interstellar*, one of the biggest star-studded Hollywood blockbusters of all time.

With the new campaign, the look of all points of sales around the world as well as merchandising material changed. The familiar orange square, which still remains the principal image, is complemented by a dynamic black and white design, representing the individual mood of all the brand's different product families.

The introduction of four new movements in 2014 created a further highlight for the brand. A trio of those new Hamilton movements (H-10, H-30 and H-40) boasted a power reserve of 80 hours, deriving from the refinement of the entire kinematic chain.

CREATION

With the Khaki Takeoff Auto Chrono Limited Edition, Hamilton wrote the next chapter of its long history of aviation. The brand's collaboration with Air Zermatt, the Swiss mountain rescue and transport company, was taken to new heights. The timepiece functions as a wrist, cockpit and table watch simultaneously. Only 1999 pieces produced.

PRESENCE

2014 was an exciting year for Hamilton, the brand known for its leading roles in the worlds of cinema and aviation.

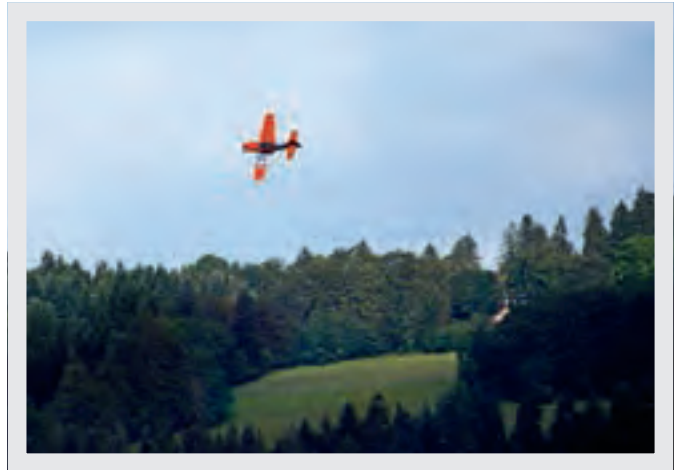

CINEMA

Hamilton watches returned to the big screen twice in 2014. The brand landed two leading roles in the new Christopher Nolan movie, *Interstellar*. Cooper, played by Matthew McConaughey, was equipped with a Khaki Pilot Day Date. His on-screen daughter Murph, portrayed by Jessica Chastain, wore a unique piece, developed especially for her character by Hamilton and the movie production team. Hamilton watches had already been seen on the wrists of action heroes earlier in 2014. The title character Jack Ryan, played by Chris Pine, and Kevin Costner as Thomas Harper in *Jack Ryan: Shadow Recruit*, both sported Hamilton wristwatches. Confirming its close involvement with the film industry, the brand once again celebrated the Hamilton Behind the Camera Awards in Shanghai and Los Angeles, paying tribute to the off-screen cinematic talent who help make the medium so enjoyable. Both events attracted international attention and were attended by celebrities such as Steve Carell, Channing Tatum, Patricia Arquette, Dan Lemmon, Ann Hui, Wang Xueqi and Huo Tingxiao.

AVIATION

Hamilton was the official team sponsor of brand ambassador Nicolas Ivanoff, who rose to new heights at the Red Bull Air Race World Championship 2014. He scored two victories, the first one in Dallas in the USA and the second one in Spielberg, Austria. Another key international aviation event was marked by the 2014 EAA AirVenture in Oshkosh, Wisconsin, where Hamilton was the official timekeeping sponsor for the 6th time. Each year, the week-long event known as The World's Greatest Aviation Celebration hosts more than 500,000 Experimental Aircraft Association (EAA) members and other aviation enthusiasts.

flik flak

www.flikflak.com

LEARNING THE TIME OF CHILDHOOD



TRENDS

Flik Flak may be 27 years old, but the world's favorite children's watch is still passionate about teaching kids to tell the time. Each watch comes in packaging that doubles as a useful pencil case, teamed with a cool time game. Color-coding on the easy-to-read watch dials helps young timekeepers differentiate between hours and minutes. The stories that unfold on the straps fire the imagination and make timely style statements.

CREATION

At Flik Flak everything is about quality and standing the test of time in a world where toys and gadgets aimed at children are all too often throw-away items. Flik Flak offers fun products that are durable and safe. Kids often test their own limits at the playground or on the sports field and Flik Flak is a reliable buddy in terms of shock, water and scratch resistance. The watches with textile straps can happily survive a whirl in the washing machine at 40°C. Grown-ups also have plenty to smile about. They know that the kids they love are wearing products made of components which don't pose health risks and that the international Swatch customer service network is always at hand.

All of the year's seasons had Flik Flak watches to count the passing seconds, minutes and hours. The frosty Swiss winter was no exception, acting as the inspiration for the Flik Flak Winter Tales Collection 2014. This duo of Swiss-made kids' watches brought design and performance magic to wannabe snow princesses and sporty Jack Frosts everywhere.



PRESENCE

Fun and creative learning make the Flik Flak world go around. Events in all four corners of the globe during 2014 introduced kids to the importance of telling the time by giving them a good time. Activities from face painting to shaking paws with Hello Kitty were on the timetable, as were making new friends and unleashing creativity.



www.tourbillon.com

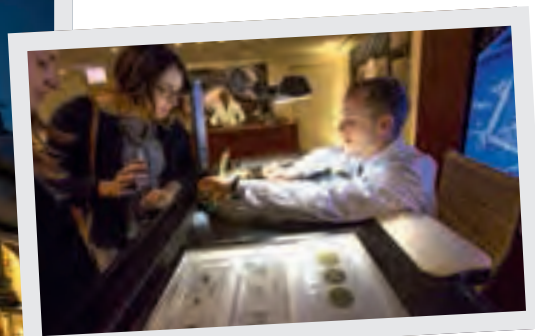

THE PRESTIGIOUS MULTIBRAND EXPERIENCE

Responsible for the distribution of Swatch Group brands in the prestige and luxury segment as well as exceptional Swatch pieces, Tourbillon continued to implement its strategy based on an exceptional offer and the most comprehensive possible service distinguished by excellence. Its results for 2014 were an expression of continuity. Synonymous with a unique experience, Tourbillon's exclusive multibrand boutique network experienced pleasing development with 20 points of sale whose top-luxury finishes, like the brands presented in a coherent setting, provided an environment conducive to discovering each one of them in total harmony.

Enhancing its influence on the other side of the Atlantic with a new inauguration at Houston's well-known The Galleria, Tourbillon now has nine shops in the United States in locations that are both prestigious and strategic. 2014 was also marked by the introduction of Harry Winston watches to the Montreux, Lugano, Puerto Banús and Baden-Baden shops, as well as by events organized with the brands to highlight their different partnerships and promote their creations.

A charity concert in support of a medical program and organized by the Artist Foundation was held in Saint Petersburg in conjunction with Breguet, whose ties with the world of music were also celebrated in the Tourbillon boutique in Porto Cervo with a piano recital accompanying the presentation of its innovations. Sponsor of the World Ocean Summit, Blancpain announced the renewal of its commitment to protecting the oceans through the Pristine Seas Expeditions with Blancpain under the auspices of the National Geographic Society at a cocktail party at the Tourbillon boutique in San Francisco. In Puerto Banús, the brand reinforced its ties with the art of living at a culinary show during the Marbella Luxury Weekend. Glashütte Original presented its new Caliber 37 at the Tourbillon boutique in Chicago with an exhibition entitled "The Art of the Chronograph", while a





retrospective “The Enchanted Journey” retraced 275 years of Jaquet Droz’s history at the boutique in Las Vegas. Omega presented its innovations and organized a VIP dinner at the Tourbillon boutique in Amsterdam attended by the Fratello Watches blog. The brand organized a cocktail party in Seattle, where an exhibition provided an opportunity to celebrate the 45th anniversary of the first lunar landing and paid tribute to the new Speedmaster at Puerto Banús. The highlights of Omega’s lunar journey were also presented in Lausanne at the Christmastime tasting event, “Le Noël des Dégustations”.





www.hourpassion.com

DYNAMISM AND ADAPTATION



In 2014, Swatch Group's mid-end multibrand store continued its growth and, paying careful attention to the sales environment in which it has been establishing a foothold, rolled out its specialist concept in three distinct formats, each specifically adapted to airport, city center or mall distribution.

Targeting an international clientele, Hour Passion has a rich, diversified offering, consisting of brands that are strong and certified Swiss-made – essentially belonging to Swatch Group – as well as an innovative architectural concept and consumer-oriented marketing.

At the end of 2014, its network comprised 58 points of sale spread across airports in Switzerland, France, Germany, the United Kingdom, Ireland, Italy, Spain and China, as well as in the metropolitan areas of Paris, London, Rome, Moscow, New York, Las Vegas, Kuala Lumpur and Penang (Malaysia), Poznań, Łódź and Warsaw (Poland) and Seoul.

In airports, Hour Passion continued its expansion with six new boutiques in international transit areas. In Asia, an inauguration at Chengdu, followed by another at Nanking, brought the number of its boutiques in Chinese airports to ten. In Europe, Hour Passion strengthened its presence at Dublin Airport with a new boutique in Terminal 1, as well as at the airport in Milan with the opening of a third shop in Malpensa's terminal 1B. In addition, two 150-square-meter sales areas were established at Madrid Barajas in Terminals 4 and 4S.

Hour Passion also developed its network in city centers, inaugurating two new addresses in Poland, in Łódź and Warsaw, followed by two boutiques in Seoul, one with an impressive 300-square-meter surface area at the Lotte World Mall and the second at the Coex Mall.

Thanks to its ability to adapt, Hour Passion also introduced its concept in appropriate and high-quality shopping destinations,

such as the outlet villages at Madrid Las Rozas, Barcelona La Roca, Milan Fidenza, Paris La Vallée Village and Frankfurt Wertheim.

Hour Passion offers its clients an education in watchmaking culture with a modern, specialist shopping experience. Its fundamentals are a clear offering and respect for the brands represented as well as customer service and advice. Thanks to this DNA, the multibrand store continues to be a strategic presence on behalf of Swatch Group in a number of markets.

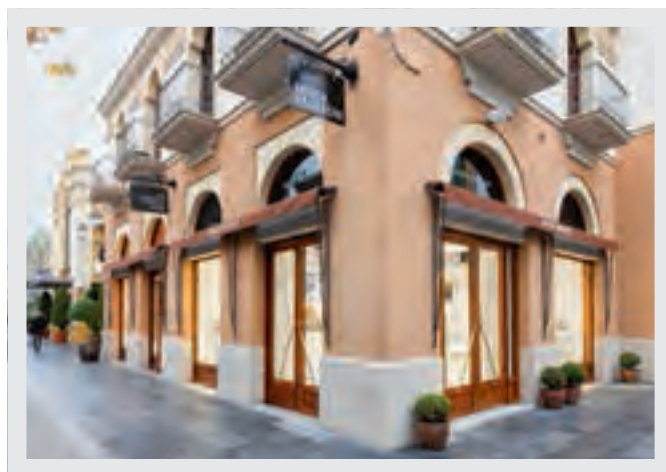

斯沃琪和平饭店艺术中心
THE SWATCH ART PEACE HOTEL

www.swatch-art-peace-hotel.com

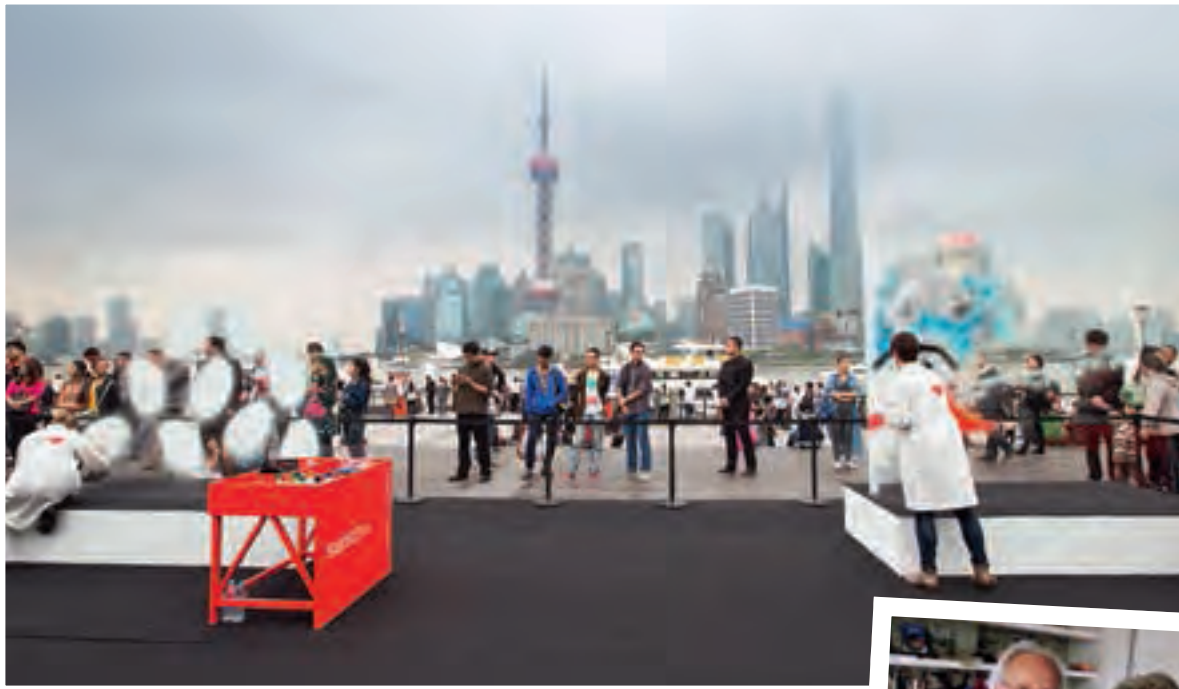

SWATCH ART PEACE HOTEL

For the Swatch Art Peace Hotel, 2014 was marked by two particularly important highlights: George Clooney's visit in May and the event celebrating the third anniversary of the artists' residency at the end of October.

An evening event connected to Orbis International in a "Secret Garden" created by Omega in the heart of Shanghai allowed George Clooney to take advantage of being in the Chinese metropolis to visit the Swatch Art Peace Hotel, a project he has followed closely since its beginnings. The actor took the time to talk to all the artists present about their motivations and work. He expressed an interest – with the same level of curiosity and open-mindedness – in a novel by a Dane, a play by a Bulgarian, the screenplays of a Chinese woman and those of an Argentinian; the paintings of artists from Australia, the United States, Sweden and Switzerland and the works of several Americans, as well as the mobile installations of an Italian. All this contributed to a wonderful time of fruitful exchanges and creative companionship that sparked irresistible enthusiasm among the artists.

Unveiled on October 31st 2014, the "Faces & Traces" exhibition provided an opportunity to display the public works left by

the 139 artists invited to the Swatch Art Peace Hotel since November 1st 2011, the official opening date of the artists' residency. The inauguration of this retrospective will remain an extraordinary moment in the living memory of the Swatch Art Peace Hotel.

In 2011, the venue was opened in the presence of the President of the Swatch Group Management Board, Nick Hayek and several important guests including François-Henri Pinault and his wife, Salma Hayek, Mikhail Kusnirovich and Tan Sri Dato' Francis Yeoh. As with this inaugural event, the one marking the presentation of the work achieved over the past three years was attended by a large number of Chinese and international officials.

Surrounded by several members of the political, economic, cultural and diplomatic community, as well as a great many media representatives and a vast audience of connoisseurs, guests had an opportunity to become acquainted with the works of many artists invited over the past three years and also to visit the workshops of resident artists. Offering a wealth of diverse activities, the day also offered a chance to catch another glimpse



of the fabulous suites on the legendary fourth floor of the Swatch Art Peace Hotel to admire a street painting being created on the Bund below the building's windows, with Pudong's skyscrapers in the background, and to watch the opening of a five-meter wide pop-up book.

In the evening, guests were able to take part in a dazzling party where they were entertained by a large number of artists, including a couple of traditional Chinese opera singers, a cosmopolitan theatre company, Swiss contortionist Nina Burri and music group Oesch's die Dritten. As the very first one to perform in public on the Bund, the traditional Swiss folk artists captivated amazed Chinese passers-by from the afternoon onwards. It all goes to show how far the yodel can really go!

The evening ended with a wild show by Biel DJ, Cee-Roo and his group, before one of the resident artists, Italian Chiara Luzzana, replaced them to get frenzied partygoers to dance the night away.

Nonetheless, even these two highlights should not be allowed to overshadow the work that continued in the background in 2014, as in the previous years. Of the 139 artists from all over the world housed at the Swatch Art Peace Hotel since 2011, 40 of them were in residence in 2014. This variety is also mirrored in certain other key figures: in three years, artists from 34 different countries of origin stayed for an average of more than four months; and around 18500 breakfasts were served by the hotel team to this exciting creative population aged between 21 and 80 years old!

Today, the Swatch Art Peace Hotel collection consists of more than 150 works ranging from opera music scores to manuscripts for crime novels, through classic drawings, paintings and sculptures, not to mention photographs, videos, films and clips as well as sound works.

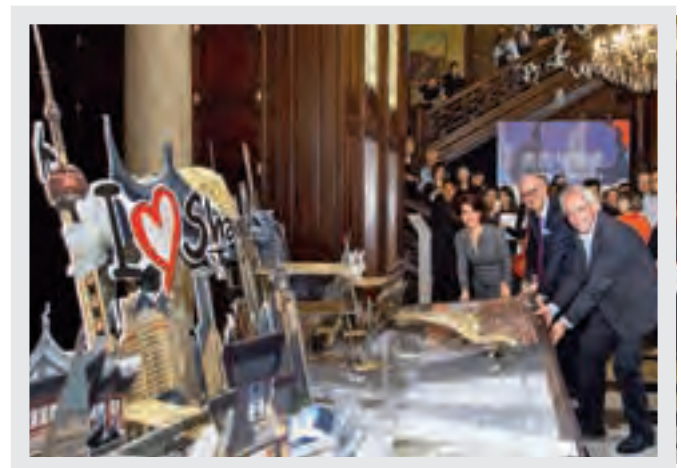
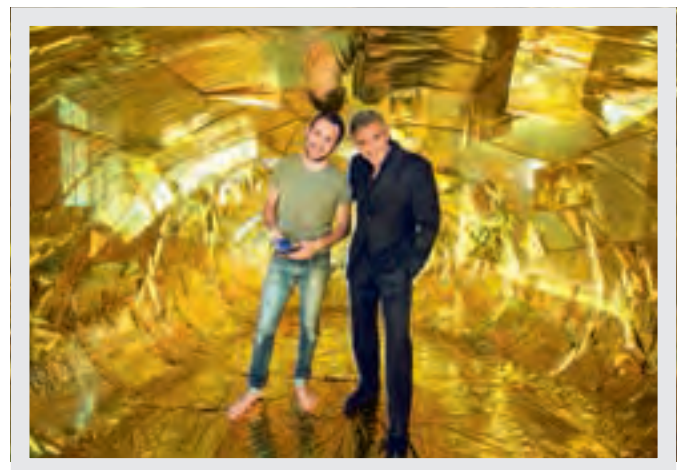



www.citedutemps.com



CITÉ DU TEMPS

In 2014, the Cité du Temps hosted 20 exhibitions and over 60 events.

HOME FROM HOME

Many Swatch Group brands used the venue as a window on their worlds. Breguet showcased its innovations that wrote watchmaking history, saluting over 200 patents since 1775. Tissot shed light on the steps that led to the creation of the Tissot T-Touch in an exhibition that celebrated the creation of the world's first tactile watch powered by solar energy. New heights were matched by new depths as Blancpain invited visitors to experience 40 days of deep water diving in South Africa to meet a legendary sea creature, the coelacanth, via film, photography and original diving equipment. In a stunning photography exhibition focusing on dancers of the Bèjart Ballet Lausanne, the company's proud partner Jaquet Droz was delighted to witness an encore of the talent that has captivated live audiences in 24 countries around the globe.

ZOOMING IN AND OUT

Throughout the year the Cité du Temps remained true to its promise of enabling artists of all disciplines, genres and origins to take center stage. The exhibition schedule imitated the action of a clever camera, with the wide-angle lens capturing content from inspiring destinations and inspirations as far apart as fairytales and the city streets. The paintings of Alberto Lanteri took on the ambitious feat of sustaining the traditions and achievements of 28 centuries of Italian art. Photographer Neftali Notario presented impressions of a round-the-world trip fuelled by contrasts, while other artists came from far-flung places stretching from Ecuador to Russia to bring talent, variety and food for thought to visitors. Creatively mimicking a camera's zoom function, the collages of Ced Vernay used confetti made from magazine pages to recreate the faces of the likes of Woody Allen, Aung San Suu Kyi, Mao Zedong and President Obama. And drawing in eyes even closer to home, the Cité du Temps finished an action-packed year with an exhibition of diverse local art put on by the non-profit organization Artraction.

PRODUCTION

WATCHES
JEWELRY



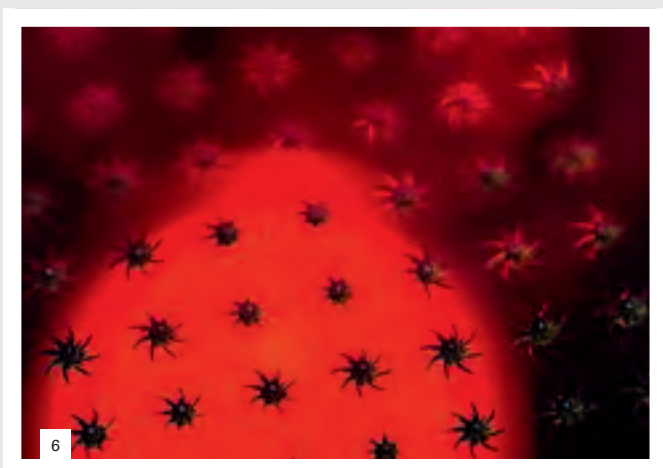
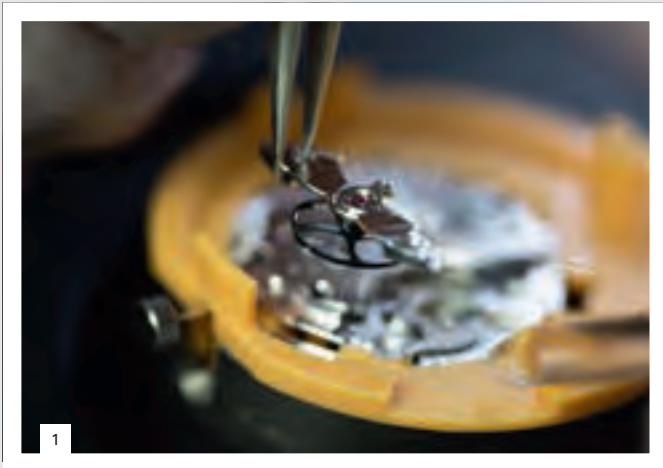



ETA MANUFACTURE HORLOGÈRE SUISSE

www.eta.ch

1 / 2 / 3

ETA Manufacture Horlogère Suisse ended the year with good figures, both in terms of results and in terms of quantities produced, notably with regard to the fire that occurred at the end of 2013 in the electroplating workshop in Building 1 in Grenchen (SO). The company was able to manage the consequences of the disaster swiftly thanks to an exceptional program. The affected premises were reassigned to other technologies. This event highlighted the company's robustness and its ability to bounce back, thanks particularly to the commitment of its employees.

2014 was marked by the deployment of technologies and skills that were put in place the previous year. The development and construction of the Swatch SISTEM51 enabled the company to lay the groundwork for the future, as this major project on an unparalleled scale has already begun to have applicable effects in terms of production, methodology and process in other areas of the company and in the assembly of mechanical movements in particular. Bringing the partners required for its realization together under one roof, the design of this movement took advantage of synergies with other Swatch Group companies. The integration of Nivarox-FAR into the company's production lines was successfully accomplished, heralding other collaborations involving a strong mobilization of skills exchanges among Swatch Group production entities. This pooling of know-how made it possible to surpass existing limits and the ensuing technologies resulted in the appearance of new professions, thus enabling employees to acquire high levels of expertise in new fields.

In the area of mechanical movements, the Omega A14 calibers (Omega Co-Axial 8520 and its variations) and the A16 (Omega Co-Axial 8500 and 8600 and their variations) were developed in their Omega Master Co-Axial versions, resistant to magnetic fields of over 1.5 tesla (15000 gauss). The success of these calibers went hand in hand with the increase in production capacity of Omega mainplates and bridges, thanks to the machining method and the flexible finishing of *ébauches*.

The site at Villeret (BE) is now fully operational and home to Omega movement assembly, which until now was handled at Saint-Imier (BE). The space that this freed was used for Longines' benefit, with the implementation of a new assembly line for the new A20 caliber (Longines L592.2), developed exclusively at the brand's request.

New calibers were developed in the area of quartz movements. The F11.001 movement allows the Rado HyperChrome Ceramic Touch Dual Timer to be operated with a finger swipe on the side of the crown-free ceramic case. The PowerDrive and PreciDrive™ technologies were introduced to the E6xx quartz range of products and to G10.xxx and G15.xxx analog chronographs.

New skills were also used in the area of external parts. The Tissot T-Race Touch, Calvin Klein color, Hamilton Khaki Pilot Pioneer Aluminum and Certina DS Podium GMT Chronograph joined Swatch in the use of aluminum cases produced at the ETA site in Moutier (BE).

The augmentation of the production facility's capabilities was made possible by an increase in and development of the staff. A great many investments were made in training employees as well as in apprenticeships, with particular emphasis on the professions of the future. In 2014, the number of apprentices trained by ETA was once again on the increase.

The different activities undertaken this year are part of the plan to continue supporting the growth of Swatch Group brands by providing solutions tailored to their needs and to strengthen Swatch Group's competitiveness with top-quality Swiss-made products.

MECO

www.meco.ch

4

In 2014, Meco demonstrated its flexibility and responsiveness, effectively fulfilling the increasing requirements of the Swatch Group brands, in terms of both quality and production volumes. The company also substantially increased its capacities and modernized its production facility.

The collaboration with Swatch Group brands during the design and production of new products was expanded. In the financial year under review, the specialist in external watch components continued to be an important partner for the development and production of new watch models in high technology ceramic and 18K Sedna gold, a precious metal alloy.

Continuous training of qualified employees in the fields of new manufacturing technologies as well as planned investments in the areas of production automation and rationalization should enable Meco to continue to develop and enhance its competitiveness, in order to take on new challenges with even greater efficiency.

FRANÇOIS GOLAY SA
Fabrication de pièces d'horlogerie
Depuis 1855

FRANÇOIS GOLAY

www.francoisgolay.ch

5

Specializing in the manufacture of top-quality complicated parts, François Golay experienced a significant increase in productivity in 2014. This was due on one hand to considerable investments made over the past few years, and on the other hand, to the implementation of production indicators through data processing provided by the recently rolled-out enterprise resource management program.

This new basis made it possible to calibrate and enhance the production facility in order to better meet the qualitative and quantitative needs of its clients, including brands from the Swatch Group prestige segment, such as Breguet and Blancpain. The consolidation of production capacity and the centralization of logistics and administrative support functions also contributed to responding positively to the large increase in demand.

In 2014, François Golay also continued the modernization of its production facility, principally with regard to the cutting and burnishing workshop. This meant that at the end of the year, new state-of-the-art machining centers were still being installed in the CNC secondary-operation workshop on the site at L'Orient (Vallée de Joux, VD). Finally, in developing tools specifically tailored to the demands of its core business, which cannot be found on the market, the company notably applied its expertise to the design, development and use in production of a brand-new glue-dispensing robot system that has already aroused the interest of other Swatch Group companies.

François Golay employees will continue to deploy their know-how in the course of their activities with a blend of strong motivation and considerable competence, taking great pride in contributing to the company's ongoing development.



NIVAROX-FAR

www.nivarox.com

6 / 7

For Nivarox-FAR, 2014 was marked by the enhancement of a large number of industrial productions.

During the year, the implementation phase of the industrial resources deployed in 2013 at the Boncourt (JU) site enabled the pace of production to achieve optimal rates in the manufacture and assembly of the Swatch SISTEM51 escapement model.

Parallel to this, and in addition to its manufacture of main-springs for the barrel in mechanical watches, Nivarox-FAR developed the production of barrel parts at two sites, with the aim of offering a complete motor function to Swatch Group movement manufacturers.

In the Co-Axial escapement sector, activities related to the assembly of the new escapement wheel, produced using the LIGA process and a silicon balance-spring – two parts manufactured by Nivarox-FAR at its site at Marin-Epagnier (NE) – were centralized at the Villeret (BE) site. Going forward, this will allow for better industrial verticalization of Co-Axial escapement production and bring it closer to the movement assembly workshops.

Despite its focus on new technologies, Nivarox-FAR also made progress in the area of its original productions, as the manufacturing line for the traditional balance-springs in Villeret was completely transformed into a high-tech workshop.

With regard to chronometry, Nivarox-FAR participated in a major breakthrough with all Swatch Group companies – and in particular with ETA and Asulab, as well as Breguet, Blancpain and Omega. This work resulted in the development of parts serving to build antimagnetic escapements, a feat that pushed the boundaries in terms of countering the negative influence of magnetism on mechanical watches. This technical advance increases resistance to magnetic fields to previously unattained levels, namely 15000 gauss, making Swatch Group the only watchmaking company in the world today capable of achieving such results.

At Le Locle (NE), the headquarters of Nivarox-FAR is undergoing refurbishment in order to bring all the centralized services closer and to optimize communication with the production sites.

In parallel, work undertaken to rehabilitate historic buildings belonging to Nivarox-FAR located in Le Locle and built at the end of the 1940s will allow the company to take its rightful place in the architectural heritage of Le Locle, which is listed as a UNESCO world heritage site.



COMADUR

www.comadur.com

8

For Comadur, 2014 was marked by an increase of the activities in the ceramic area as a result of increased demand from Omega for its Speedmaster Dark Side of the Moon and Grey Side of the Moon models, the launch of the entirely ceramic Fifty Fathoms Bathyscaphe chronograph and the introduction of the new Rado True collection.

This growth was underpinned by ongoing development, based on ultra-modern, increasingly high-performance production methods. The internalization of the complete assembly of cases and bracelets on automatic assembly lines is currently in progress. Over the year, considerable investments were made in facilities, machines and surface areas to anticipate and meet the needs of the brands.

The manufacture of raw material (feedstock) was supplemented by a production line in order to meet the growing needs for smaller volumes and ever-more demanding requests for new colors. Other developments for new materials are also underway.

With its concern for continuous improvement in client services, particularly with regard to lead times, Comadur focused on production methods enabling faster set-up times, also optimizing flows between the various manufacturing operations resulting from working on logistics and standardization of tools, throughput time and a reduction in outstanding volumes through the introduction of takt time.

To enable the arrival of new equipment for ceramic at the Col-des-Roches site (Le Locle, NE), some of the activities in the sapphire crystal area had to be moved temporarily to the Les Brenets site (NE). This sector enjoyed a steady increase in production volumes and the machine fleet is currently undergoing modernization to reduce throughput time and cost price with the aim of reinforcing the Swiss Made concept.

The production of watch stones developed in line with the needs of movements and the machinery were modernized and overhauled to better meet quality requirements.



RUBATTEL ET WEYERMANN

9

In 2014, Rubattel et Weyermann focused heavily on optimizing its manufacturing processes and alongside the strengthening of its organizational structure, continued the ongoing expansion and improvement of its activities on behalf of Swatch Group's brands in the prestige and luxury segments.

Innovation and new technologies also represented a significant area of development. The increase in dials made of hard materials continued the upward trajectory that has taken place in recent years, leading Rubattel et Weyermann to rationalize its manufacturing and to prepare a dedicated production line which will be an integral part of its future factory.

In light of this, the construction of the new building and preparation for the move were a key part of the company's various projects. In addition to the increase in volumes to meet the growing need of its clients, and thanks to the considerable investments already made and those still planned, this unique phase will enable the dial maker to accelerate the verticalization of its production. Much thought is also being given to new ways of handling logistics flows and optimal development of the work environment in line with the specific characteristics of each trade.

MOM LE PRÉLET

10

In 2014, MOM Le Prélet maintained considerable growth in the area of high-volume products, expending particular effort on controlling production flows, developing greater versatility and optimizing manufacturing processes.

The automated *ébauches* production line represents a great asset in controlling the supply process with regard to baseplates. The addition of new production methods enabled the scope in this area to be extended and other manufacturing operations to be undertaken. Part of a process of continual improvement, this rationalization is intended to contribute to an increase in the desired quantities produced. In addition, logistics organization into islands, or product lines, enabled the optimization of production flows and the adaptation of workloads according to the capacity required.

Finally, MOM Le Prélet continued to work with Rubattel et Weyermann and, looking constantly for possible synergies, these two specialists in the creation and manufacture of exceptional dials increased their exchanges and shared their know-how in researching solutions to respond to technical and industrial challenges.



UNIVERSO

www.universo.ch

11 / 12 / 13

The European leader in the manufacture of hands and supplier of applique dials, Universo enjoyed an excellent year in 2014 in terms of both results and volumes, allocating costs optimally across all the production lines both in the Hands and Appliques Divisions.

HANDS DIVISION

Production capacity in the Hands Division was used to its full potential during the first three quarters of 2014 and the slight stagnation in orders noted at the end of the year was a reflection of a cautious approach on the part of Swatch Group brands with regard to sales forecasts in their main markets. The machines and other instruments that were part of the huge investment program launched in 2012 were virtually all installed in the workshops producing hands in diamond-polished brass, as well as in gold or steel. In order to perform the many adjustments required, brand-new high-tech galvanic treatment chains were brought directly to the premises of Universo's new factory a few months prior to the relocation of the rest of the workshops.

APPLIQUES DIVISION

The Appliques Division was also affected by all the investments made, with regard to machines and other specific production tools. In addition to the manufacture of brass and gold appliques for the dials of the most beautiful watches made by Swatch Group brands, intensive work was done on the development of a more industrialized production line.

NEW PRODUCTION SITE

With a surface area of more than 18000 square meters spread over three floors, Universo's new factory – for which construction began at the end of 2012 – is ready to accommodate the entire company. The Appliques Division workshops were the first to move into the building, and were followed shortly afterwards by the entire Hands Division and the administration. In line with the strategy announced by the President of the Swatch Group Management Board, Nick Hayek, this building will accommodate a training center for apprentices from several Swatch Group production companies, including Universo.



MANUFACTURE RUEDIN

14

After devoting significant investment to improving its production facility over the past few years, Manufacture Ruedin is now reaping the benefits, having achieved double digit growth in 2014, and has demonstrated its reactivity by meeting the requirements of Swatch Group brands both qualitatively and quantitatively.

Several measures designed to reduce the Jura-based company's energy consumption were also implemented. In particular, these included improvements to the building's insulation, providing better regulation of inside temperatures.

In 2014, new product development in collaboration with Swatch Group brands once again constituted a major area of activity for Manufacture Ruedin. In this way, the company's main clients benefited from professional support in the creation of products which included models from the De Ville Butterfly collection as well as the Seamaster 300 and Aqua Terra Master Co-Axial for Omega; while for Rado, the emphasis was placed on the production of the Integral and HyperChrome Ceramic Touch Dual Timer models; and efforts on behalf of Longines were focused on the manufacture of additional sizes for The Longines Elegant Collection and for the Flagship Heritage watch.

In the future, Manufacture Ruedin will continue its investment in and renewal of its fleet of machines, in order to maintain its competitive edge and reinforce the quality of its products. The company will also be able to rely on qualified, well-trained staff in order to continue providing its clients with irreproachable service.

LASCOR

15

In 2014, Lascor continued to develop the bicolor and steel bracelets supply in the *haut-de-gamme* segment and adapted its logistics structure and production facilities for the manufacture of high-end components on an industrial scale. New technologies were introduced that delivered high-quality parts produced on this large scale.

Training was steadily developed and monitoring methods were introduced to train the production staff. Furthermore, many employees were transferred and assigned to different production sectors due to their versatility.

The recovery of precious metals in the production department was improved thanks to new procedures and new cleaning and recovery systems.

Communication with customers was constantly improved and should be even more effective through the establishment of a product lifecycle management (PLM) system in collaboration with Manufacture Ruedin.

The issues of workplace security and environmental protection were addressed and, to consolidate the actions taken, Lascor defined a Quality-Safety-Environmental system compliant with international standards, whose certification process is underway.

LASCOR

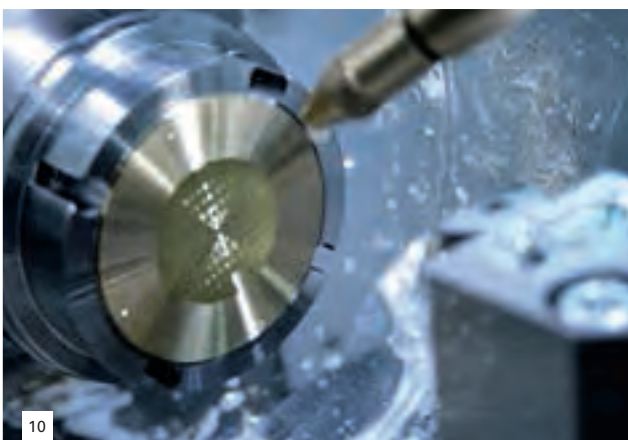

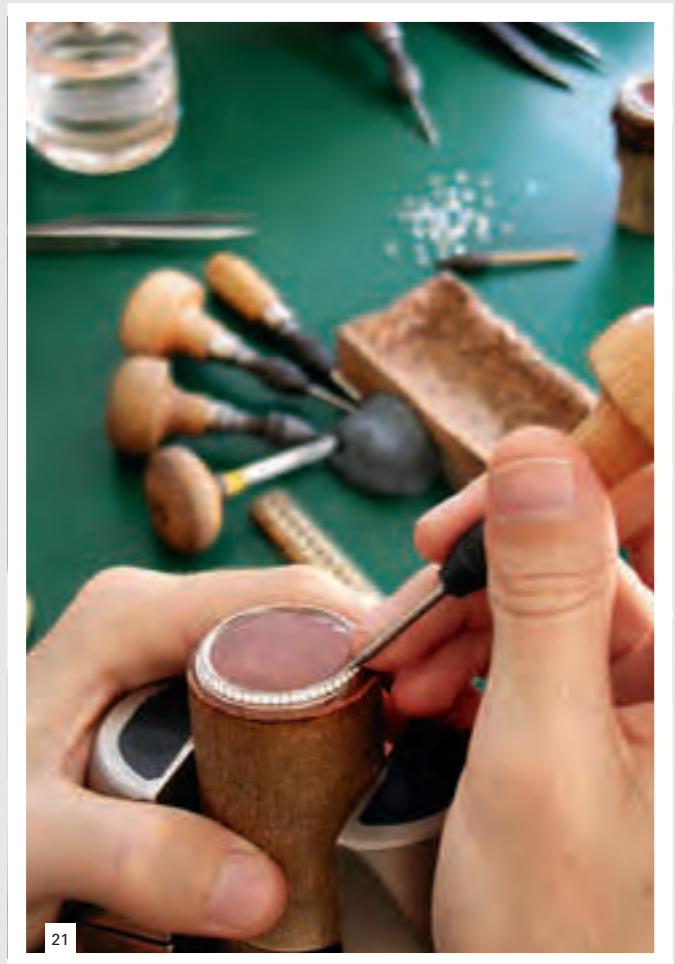

SIMON & MEMBREZ
HABILLAGE HORLOGER HAUT-DE-GAMME



SWATCH GROUP
THE SWATCH GROUP ASSEMBLY SA

SIMON ET MEMBREZ

www.simon-membrez.ch

16

Following a year of integration and transition in 2013, which included expanding activities for brands in Swatch Group's prestige segment while maintaining those for third-party clients, Simon Et Membrez is now well-integrated into Swatch Group, offering this producer of top-quality cases a great many technological opportunities.

Synonymous with consolidation, 2014 was marked by the enhancement of productivity and quality, as well as a number of significant reorganizations, which contributed to achieving the objectives set and laid the foundations for future development. The Assembly Department in particular underwent a sweeping reorganization based on lean management. Introduced across the board, this system had already been implemented in the Polishing Department, with very positive results. In addition, Simon Et Membrez also continued manufacturing top-quality metal bracelets for the Swatch Group brands, a new activity started in 2013 and destined to develop.

From its site in Delémont (JU), the company continued to manage the financial, personnel and logistics affairs of Termiboîtes, a company based in Courtemaîche (JU) and fully dedicated to finishing – satinage and polishing – which is an important element in Simon Et Membrez' manufacturing operations.

The future of Simon Et Membrez looks extremely encouraging, with growth in all sectors, the development of new activities, expanded production of exotic materials and an adjustment of social conditions aimed at enhancing its employees' well-being.

NOVI

17

After a smooth integration into Swatch Group, 2014 provided an opportunity to demonstrate Novi's primary qualities, which became apparent through its versatile, flexible, reactive industrial infrastructure, ensuring a high level of competitiveness and quality in line with the requirements of the various Swatch Group brands.

In 2014, Novi continued its development according to its four watchwords, namely "Flexibility – Quality – Competitiveness – Respect for deadlines", in order to better meet the current and future needs of Swatch Group brands in the area of the assembly of mechanical movements (T1), watch finishing (T2) and after-sales service.

During the year, the company particularly intensified the synergies and sharing of competencies with the ETA movement assembly sites. Activity transfers, staff exchanges and shared services significantly contributed to the global optimization strategy in the area of assembly within Swatch Group. Partnerships with Swatch Group brands also increased exponentially, ensuring the best possible leverage of Novi's skills in the field of watch finishing.

Resolutely focused on the future, Novi aims to continue enhancing its competencies, its internal versatility and the highly technical nature of its equipment, in order to be ready to absorb an increase in volume and meet the future requirements of its clients in its three spheres of activity.

SWATCH GROUP ASSEMBLY

18

For Swatch Group Assembly, 2014 was a record year in terms of volumes produced and product launches. Activities again focused on the flexibility of the assembly and on the development of new lines and modular islands. Process-integrated quality controls were also implemented in the assembly and storage sectors.

The implementation of islands and the control of flows – such as establishment of an island dedicated to bracelet fitting near the adjacent T2 area – helped improve flexibility and expand the production range. The extension of flexible cells and improvement in stock management continued. Following the increase in production capacities thanks to additional surface area made available in 2013, ongoing improvements made in 2014 enabled Swatch Group Assembly to better respond to the needs of the brands and to rapid market changes.

Finally, the company remains the training competence center for Swatch Group, for which it hosts apprentice watchmakers. Through its training cell, it is also committed to the development of new products and to supporting the versatility of its employees, who are thus offered training and work opportunities.

Thanks to these activities in the realms of the environment, processes and human resources, Swatch Group Assembly has consolidated its position as the biggest finisher in Switzerland for mid-segment products. The company continues to develop the expertise that enables it to assemble all types of watch – from quartz models to chronographs and mechanical timepieces, not to mention Tissot's touch screen T-Touch – and to offer each and every one the same throughput time, regardless of the level of complexity.



DRESS YOUR BODY (DYB)

19 / 20 / 21

In 2014, Dress Your Body (DYB) remained on course, despite a somewhat unstable economic and geopolitical environment.

The setting and manufacturing department maintained its production volumes, while increasing the number and complexity of developments of parts made and set. The integration of the manufacturing of appliques and indexes on dials with high technical and aesthetic requirements enabled the CNC machining, setting and finishing development units to further improve the quality and efficiency of their interactions, in order to deliver products on budget, on time and in line with the required quality standards. Hand-adjusted mechanical setting was also added to the range of techniques offered, reinforcing the level of competency of the mechanical setting department and opening up new markets. The acquisition of new 5-axis CNC machining centers enabled the continuation of the automation strategy for mechanical manufacturing and preparation in setting with the aim of cost reduction and internalization of production.

For the DYB jewelry unit, the increasing success of the Breguet Haute Joaillerie collections required the hiring of additional jewelers and polishers and the doubling of the surface area devoted to this activity. 2014 was particularly marked by the creation of the Les Volants de la Reine collection, a veritable acknowledgement of the dresses worn by Marie-Antoinette, and a perfect expression of the exceptional know-how of the company's craftsmen, as well as their ongoing quest for refinement, precision and perfection, both in terms of jewelry and watch-making.

In its capacity as a buying center for diamonds and precious stones on behalf of Swatch Group brands, in 2014 DYB Gems continued to offer the services of its gemology experts, as well as the supply and cutting of stones. Actively participating in its clients' product development, DYB Gems once again provided consulting services on the selection and purchase of diamonds and other gems, and supplying calibrated stones. Thus, DYB Gems leveraged its knowledge of the diamond market – whose overall stagnation continued in 2014, resulting in suppliers being under heavy pressure – and leveraged synergies between the complementary purchases of the Swatch Group brands, to ensure a supply focused on the best possible market conditions, while maintaining strict quality standards.

ELECTRONIC SYSTEMS



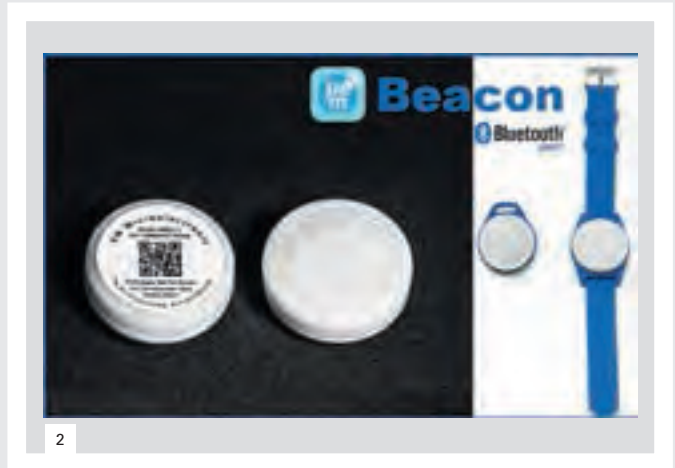



EM MICROELECTRONIC

www.emmicroelectronic.com

1 / 2

The successful launch of innovative high volume products helped EM Microelectronic to achieve solid growth in 2014.

The production facility increased its output and productivity significantly; for example, Front-End productivity increased dramatically in the second half of 2014 compared to the same period in the previous year. Full production capacity was reached and investments to expand the capacity in 2015 were initiated. Additionally, the pre-development for the next technology generation in the Front-End started and has shown promising results.

EM Microelectronic further demonstrated its continuing commitment to meeting the highest standards in ultra-low power technology, a key characteristic for components in the watch-making segment, but increasingly also in the rapidly expanding field of the Internet-of-Things.

In cooperation with ASICentrum, Swatch Group R&D and CSEM, EM Microelectronic launched a project to give its designers the tools to reach the ultimate limits of ultra-low-voltage and ultra-low-power integrated circuit design. These efforts will secure EM Microelectronic's leading position in providing forward-looking technology – both in process and design – to its customers.

In the Watch Business Unit, EM Microelectronic started the volume production of a new high-precision circuit featuring a time drift smaller than 10 seconds per year. The device integrates a temperature compensation function and is embedded along with the tuning fork crystal in a moisture-resistant ceramic package.

EM Microelectronic also developed a new high-performance Real-Time Clock circuit, together with Micro Crystal and CSEM, which has now been successfully industrialized. This is another ultra-low power, high-precision circuit with temperature compensation, bundled together with a crystal in the same ceramic package.

The sensor interface circuits developed and manufactured by EM Microelectronic's Motion & Optical Sensing Business Unit found acceptance in high volume mobile platforms. Pressure sensor functions in particular have become mainstream features in current generation smartphones; for EM Microelectronic this translated into high volume silicon production and deliveries.

EM Microelectronic's product pipeline also yielded next generation sensor IC elements that will secure volume business beyond 2016.

The SENtral sensor fusion product entered volume production with design wins at major consumer electronic system houses in Europe and Asia. Electronic compass and precision navigation applications are based on this circuit.

Volume and revenue growth in EM Microelectronic's Smartcards & Smart Systems Business Unit was more than twice that in the telecom sector. The smartcard circuit portfolio will be completely refreshed in 2015.

In the RFID Business Unit, one of EM Microelectronic's longest-term businesses, high-frequency products also experienced revenue growth. A new generation of AES-based immobilizer and hands-free passive keyless entry/keyless go circuits was finalized. Aimed at the automotive market in Europe, this product also targeted emerging markets in Asia where "comfort" features are becoming increasingly important.

A new dual-frequency circuit (EPC and NFC), scheduled for production in 2015, is well advanced. Many applications will benefit from the possibility of sharing a memory segment between logistics applications (EPC protocol) and end-user applications (NFC link with the smartphone).

The Wireless & Sensing Business Unit continued to consolidate its portfolio of low-power connectivity solutions.

A Bluetooth Smart controller was certified in its latest version which embeds an efficient power-saving scheme when the device is connected. This controller differs from other SoC solutions on the market, as it can be combined as a low-cost and low-power add-on with any type of host microprocessor.

EM Microelectronic also announced a fully-certified Bluetooth Beacon, which leverages several Swatch Group technologies: Bluetooth Smart controller, micro-processor and battery. With more than 12 months of autonomy, this beacon can be customized to embed specific sensors such as temperature, accelerometer, pressure, etc.

EM Microelectronic, along with short-range communication products, qualified a long-range and low-power 2.4 GHz transceiver suitable for applications where tiny, low-cost and long-range (14 km in LoS) devices are needed. It comes with a dedicated development kit. By addressing both proximity-based communication using Bluetooth Smart and long-range links, EM Microelectronic is uniquely positioned on the market of low-power radio microelectronics and modules.

Finally, the plastic display technology that is now widely used by Swatch Group watch brands (Swatch, Tissot, Calvin Klein watches + jewelry) also worked its way through external customer products with focus on the wearables that use the unique features of this technology – bendable, ultra-thin and lightweight – in combination with EM Microelectronic ultra-low power capabilities. Thanks to these new products and the remarkable increase of the output of the plastic display manufacturing line, revenue of EM Microelectronic Display & Touch Modules Business Unit increased significantly. While the more traditional glass display business remained stable, the outlook for 2015 is again encouraging as plastic display technology also enabled EM Microelectronic to address a new and promising market segment using displays for which the light passing through them can be modulated with an electronic signal.



RENATA

www.renata.com

3 / 4 / 5

The Swiss specialist in miniaturized energy supplies once again recorded healthy growth in all its product lines.

Watch batteries recorded pleasing growth rates, both in the after-sales market and in the Swiss quartz movement sector. This trend is above all the result of improvement in delivery times and tailor-made advice to the clientele.

Turnover increased significantly in the sector of lithium button cells for industrial use. There was especially strong demand for very competitive new products with customized contacts for direct soldering onto the baseplates of devices used for invoicing systems.

The highly successful launch of several products in the rechargeable battery sector allowed the doubling of turnover in this segment. Continuing the introduction of innovations and the extension of rechargeable solutions for watchmaking and other mobile devices in particular will be an essential element for the future. The presentation of a new rechargeable button cell during the Electronica Fair in Munich aroused great interest in this regard. This product was launched on both the original equipment and repairs markets simultaneously.

Given the increasing complexity of safety regulations for lithium batteries, Renata has developed special childproof packaging, which was successfully tested and certified compliant with the EN 862 standard.

Several optimization initiatives were implemented in production in order to cope with the increase in demand, also for the future. Significant improvements, such as those made in the injection mold department, enabled an increase in productivity, while electric consumption was considerably reduced thanks to targeted environmental measures.

As in the preceding years, Renata's presence in the markets was supported by its participation in a number of trade fairs. During the year under review, the company was present notably at the MD&M fair in Anaheim (United States), at Baselworld and at the Hong Kong Watch & Clock Fair, as well as at the Medtec fair in London and Electronica in Munich.



MICRO CRYSTAL

In 2014, international production over-capacity in the standard quartz sector and the most recent drop in the yen, which benefits Japanese competitors, caused a further drop in prices. Today, however, Micro Crystal is less dependent on low-cost products and achieves most of its turnover with integrated quartz products with a high added value.

Highly integrated quartz products launched during the year under review allowed a further reduction in the company's dependence on the mobile telephone sector, which is highly sensitive to price fluctuations. These are adapted to new fitness trackers, pedometers and all types of smart watches, whose demand increased substantially in 2014.

Due to extensive competence in terms of development and manufacture, Micro Crystal has the ability to swiftly adapt its new integrated quartz products to market needs. This enabled the launch of several innovations, including a thermo-compensated, low-consumption miniature real-time clock with a completely new design and extremely high accuracy. The integrated circuit is made by associate company EM Microelectronic and the principal functionalities have been patented. Another new development relates to an ultra-low-power quartz module, which enables watches integrated to mobile devices to function in the background for years, virtually without discharging the battery.

In the watchmaking sector, in 2014 Micro Crystal once again played a strategic role as the only non-Asian quartz manufacturer, thus supplying products required by Swatch Group. The exploitation of technical synergies and the continued improvement of integrated quartz modules allowed the reduced cost manufacture of quartz watches with vastly improved accuracy.

The medical sector also represents an important segment for Micro Crystal. Due to its years of experience with quartz for pacemakers and defibrillators, the company also managed to get a foothold in the field of neurostimulators, a new entry to a slow but constantly growing market, in which qualitative excellence, strict control of processes, perfect traceability of products and confidence in the supplier are crucial.

Micro Crystal has every confidence in its capacity to compensate the strong price decline of standard quartzes in the consumer products section through the transfer of its activities to integrated quartz products with significant added value. The implementation of this strategy during the year under review has already enabled a clear improvement in results and will be continued in 2015.



6



7



8

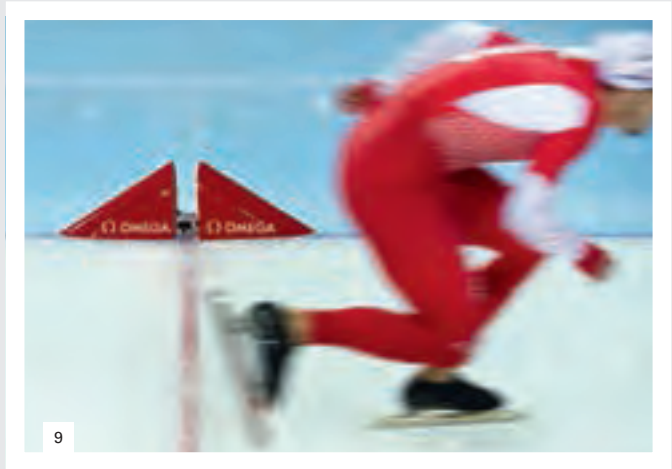

9

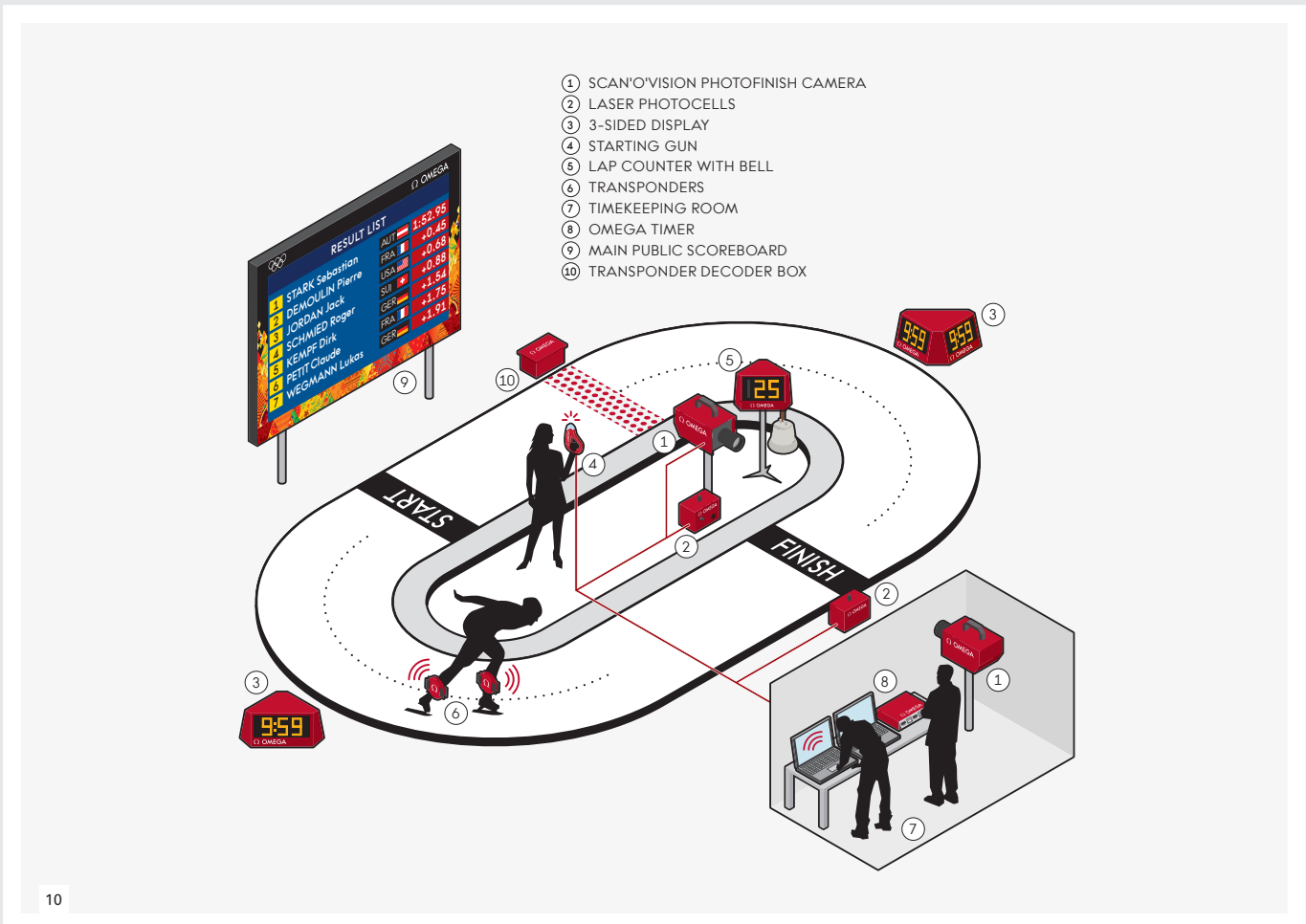

10



SWISS TIMING

www.swisstiming.com

8 / 9 / 10 / 11

The year got off to an exciting start for Swiss Timing! Indeed, the Sochi 2014 Olympic Winter Games under the banner of Omega initiated a very busy year in terms of multisport events.

The Glasgow 2014 Commonwealth Games were held in July and Swiss Timing provided its services for Longines, the time-keeper of record. There was an unusual twist at this edition: the para-sport events were presented along with the competitions for able-bodied athletes. The inclusiveness created a positive atmosphere and was welcomed by spectators.

Attention was then focused on China and the Nanjing 2014 Youth Olympic Games with timekeeping by Omega. Golf and rugby sevens, which had never been part of an International Olympic Committee (IOC) event, were included in the program.

Swiss Timing was on the scene with Tissot at the 17th Asian Games Incheon 2014, South Korea in October. These were followed by the 2014 Asian Para Games, which delivered not only intense sporting moments but lots of emotion.

SportAccord organized the 4th edition of the World Mind Games in Beijing and Swiss Timing technicians provided services, including the Games Management Systems, for Rado.

In 2014, Swiss Timing was also involved in a number of world championships among which were gymnastics in Izmir, Turkey for Longines, ice hockey in Minsk, Belarus for Tissot, and swimming (short course) for Omega in Doha, Qatar. The company was also on hand for the Basketball World Cup in Spain with Tissot.

New products and technologies were unveiled in 2014 including a brand-new photofinish camera and a new generation of on-field scoreboards. Both were introduced in Zurich at the European Athletics Championships with Omega.

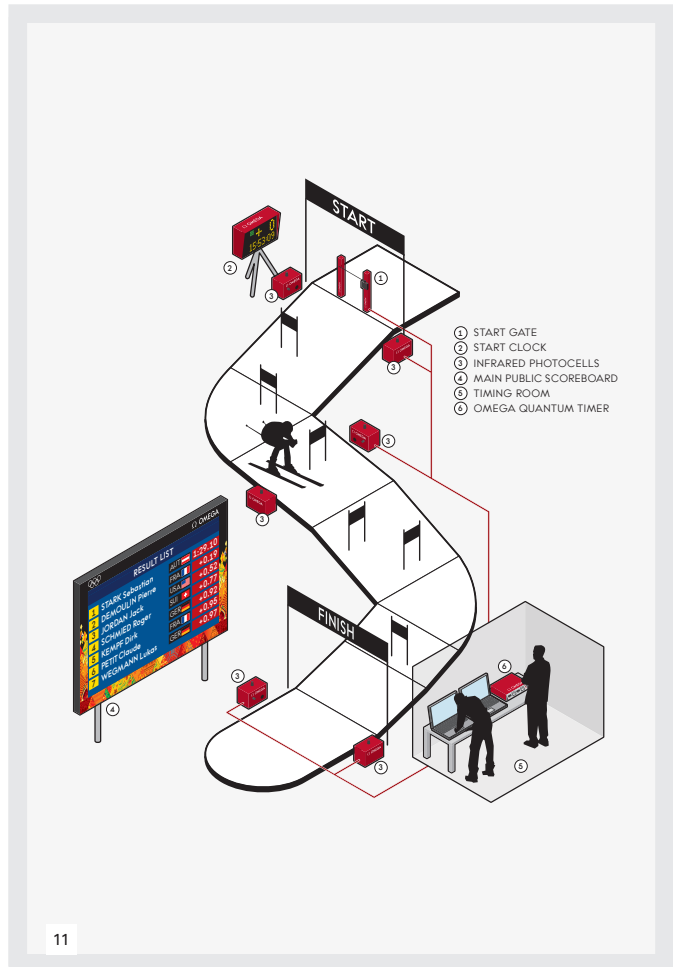

CORPORATE, BELENOS



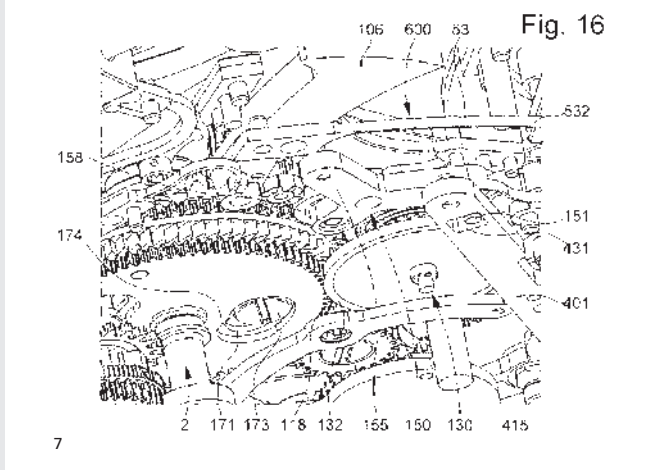
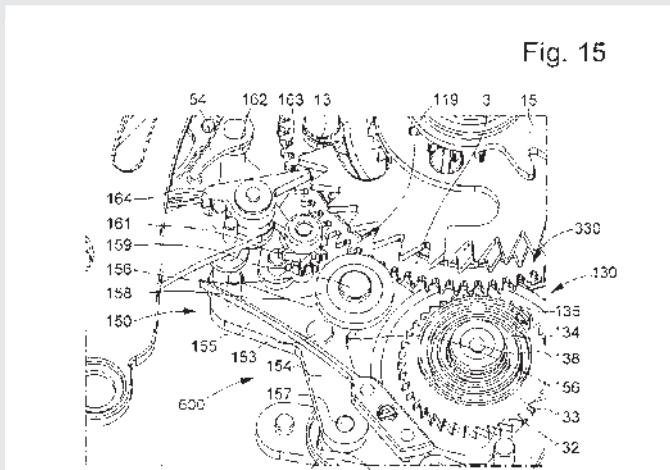
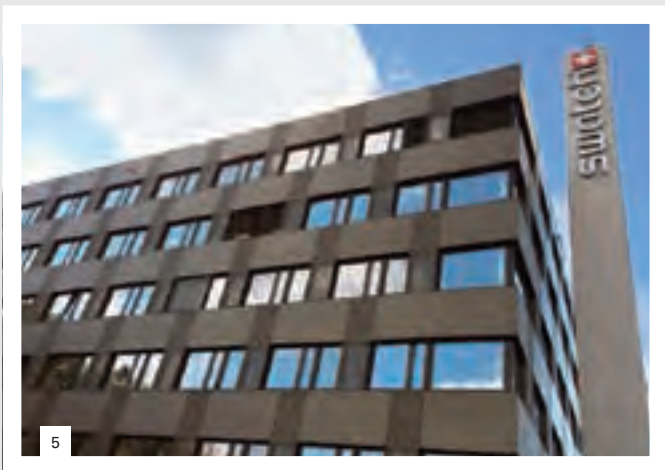
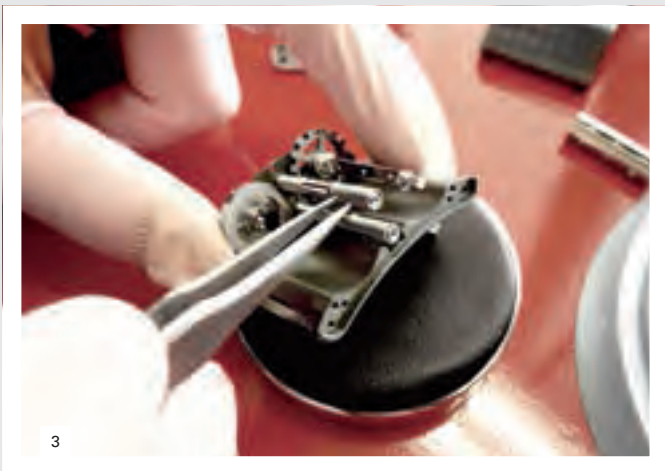
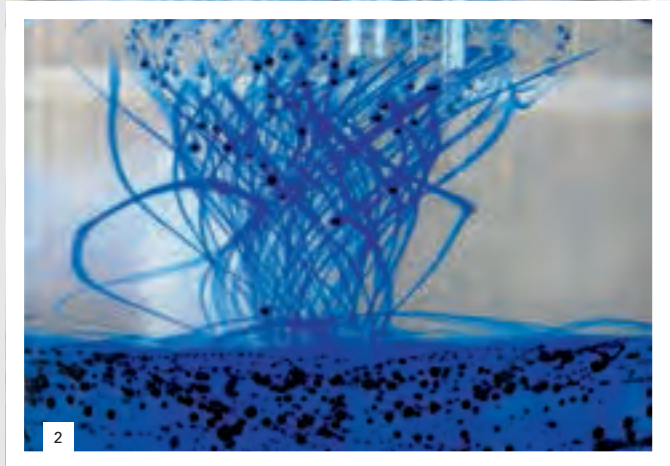



ASULAB



CDNP

SWATCH GROUP RESEARCH AND DEVELOPMENT

The Swatch Group Research and Development Ltd, founded in 2005, encompasses the activities of Swatch Group's research divisions as well as certain ones responsible for pilot productions and special products. Along with these activities, it is also involved in coordinating technological innovations for various other Swatch Group companies.

DIVISION ASULAB

1

As Swatch Group's central research and development laboratory, Asulab's core mission is to design technically innovative watch products, subsystems and components and to develop state-of-the-art manufacturing technologies. To accomplish this mission in 2014, Asulab once again made its know-how and new equipment available to the brands in order to produce original products that were presented at various events throughout the year.

Asulab continued to maintain close contact with the different Swatch Group companies and brands, pursuing joint projects and ensuring that the technical results obtained corresponded as closely as possible to the needs expressed. The acquisition and implementation of new competencies and technologies continued to be important objectives for Asulab, which realized them through targeted collaborations with the most renowned research institutes in Switzerland and abroad.

2014 provided an opportunity to confirm the importance of the multidisciplinary approach of which Asulab's expertise is a part, as well as the role of a good working relationship with its partners within Swatch Group allowing the rapid achievement of ambitious objectives. The development of the Swatch Liquid Touch is an excellent illustration of this, as this watch combines a case made of an amorphous metal alloy developed in-house and called "Dreamalloy", with a Bluetooth 4.0 connection, making it possible to interact remotely with a smartphone or tablet, such as taking group selfies.

The combination of laser engraving on hard materials and hot forming of amorphous metals enables stone setting in zirconia-based ceramic or in sapphire crystal. Certain Swatch Group brands enjoying the benefit of this innovative technology were thus able to present unique timepieces as world firsts at Baselworld 2014. New variations on this original approach are under development and will soon be made available.

Finally, several other innovations were made available to Swatch Group brands and production companies, such as the brand-new watertight push-button for use underwater, which was developed in partnership with Mecor. Another important direction involves straps, which are now available in two new materials: a completely new anti-bacterial rubber with significantly improved wearer comfort on the wrist while providing all the colors required by the brands, as well as an aesthetically original new leather.

DIVISION MOEBIUS

www.moebius-lubricants.ch

2

A division of The Swatch Group Research and Development Ltd, Moebius specializes in the production and commercialization of lubricants and epilames used in the field of micro-technology and developed to meet the highly specific needs of watchmaking applications. During 2014, Moebius continued its program of continuous improvement with the objective of increasing production capacity while strengthening the reliability of its products. In order to meet the needs of the future, Moebius also reinforced its program for development and innovation, notably by working in close collaboration with the Asulab division and with Swatch Group production companies such as ETA and Nivarox-FAR, as well as with well-known university institutions.

DIVISION CDNP

(CENTRE DE DÉVELOPPEMENT DES NOUVEAUX PRODUITS)

3

As a centralized Swatch Group development department, the CDNP's mission is to ensure and promote the standards, norms and design and construction rules for the manufacture of aesthetic watchmaking components. In order to provide industrial innovation and added value to the field of watchmaking decoration, the tasks of assessing new materials and incubating new processes were strengthened. To reach these objectives, an experienced, multi-disciplinary team of designers, engineers, industrial design engineers and mechanics combine their know-how for the best results by drawing on their specific expertise and on cross-exchanges with professional acquaintances.

In 2014, in collaboration with modelers and 3D builders, designers once again imagined unprecedented creations for different Swatch Group brands. At the same time, they contributed to the definition of components produced through additive manufacturing, as well as the creation of new watch cases in aluminum, whose first commercial launches during the year were a resounding success.

The CDNP continued to offer its client brands rapid prototyping services that incorporated the creation of mock-ups in synthetic resin on one hand and on the other, additive manufacturing of prototypes in metallic alloys. The latter activity enjoyed new momentum with developments achieved through the application of new selective laser melting processes applied to innovative metallic powders.

In addition to its usual operational achievements – the manufacture of prototypes and small series with state-of-the-art CNC machining equipment and the assessment of new materials in different forms – the CDNP completed the development of tailor-made processes and equipment at the end of 2014. This equipment, whose performance satisfied the initial requirements, was transferred to client production units and in due course, can be deployed.

Finally, CDNP work in the area of packaging presented the brands and production companies with new solutions for conditioning and multi-site transport of watchmaking components and finished products, which meet economic, ecological and quality assurance requirements.



BELENOS CLEAN POWER

www.belenoscleanpower.com

4

In 2014, the photovoltaic installation on the roof of the ETA building demonstrated the full functionality of the Belenos micro-inverter. Security aspects were improved and the first necessary certifications were obtained. On the manufacturing side, a complete pilot production was established on the ETA premises in order to assemble the electronic components. A Swiss partner company will perform the final assembly integrating the connectors and the cables. It will also use its worldwide network in the PV industry to market and sell the micro-inverter product under the brand name "Blue AC".

The cathode material developed by Belenos has proven to deliver 50% more energy storage capacity than the best commercially available rechargeable lithium batteries. For that reason, Renata is considering integrating this new cathode for the development of a high-performance rechargeable button cell. Ongoing syntheses of well-tuned nano-crystal electrode materials continued to deliver very promising results. Also, the Belenos battery team was able to realize the first functional solid-state battery avoiding the use of unstable and dangerous liquid electrolytes. All these significant results were protected by international patent filing, providing cutting-edge advantages to the future Belenos battery device.

The hydrogen battery plug-in version of the Fiat 500 was tested for an additional 40 000 km, demonstrating the robustness of the Belenos fuel cell system. Operated as a range extender over 57 000 km in total, the system proved itself able to double the range of the electric vehicle in any conditions. In parallel, a highly efficient 17 kW hydrogen/oxygen fuel cell was integrated into stationary uninterruptable power supply equipment from Newave/ABB with the financial support of the Swiss Federal Office of Energy (SFOE).

A complete electrolyzer system producing 1Nm³/h of hydrogen was designed, built and successfully tested by the Belenos team. Based on the new electrolyzer stack design producing oxygen and hydrogen directly at 30 bar, the system will be installed within a 100 kW mini-electric grid at the Swiss Federal Institute of Technology in Lausanne (EPFL).



INGENIEURS CONSEILS EN BREVETS

ICB

7

The essential missions of ICB Ingénieurs Conseils en Brevets are the protection of Swatch Group's technical innovations, the enhanced value of acquired technological know-how, market intelligence and the fight against counterfeits.

In 2014, ICB continued its activities to identify technical innovations in the various research and development companies and entities of Swatch Group in order to ensure optimal protection of its technological assets. The number of new patent applications filed to protect the developments of the Swatch Group companies was maintained at a high level compared to the previous years. This was the result of the continued awareness of all those involved in research and development of the importance of patents as part of the strategy of an innovative company, and an efficient synergy between ICB and all the engineering and research teams from the different Swatch Group companies. This collaboration was once again particularly important, not only in the watchmaking domain but also in Swatch Group's non-watchmaking activities.

Substantial efforts were made to support the Swatch Group brands in their strategies to penetrate international markets through patent protection. With this in mind, the financial investments to obtain patent protection for their new products abroad continued in a targeted manner in 2014, so as to cover the main markets and production sites.

In collaboration with Swatch Group's legal department, ICB continued to support the various companies and departments to ensure that their rights were defended.

In 2014, ICB management maintained its strategy of controlling its operating costs. It also focused on the stabilization of operational expenses relating to the maintenance and acquisition of patent rights. Consequently, ICB's end of year financial results were positive, and in line with the budget forecast.



SWATCH GROUP QUALITY MANAGEMENT

The mission of Swatch Group Quality Management (SGQM) is to establish the standards for quality assurance and the security of products brought to the market. The aim is to ensure environmental and legal conformity and reliability by making specific knowledge and competencies available to the Swatch Group companies.

LEGAL CONFORMITY

In 2014, SGQM monitored the evolution of the following legislation:

RoHS: Dossiers for the four-yearly renewal of exemptions allocated to the industry within the framework of the European RoHS (Restriction of Hazardous Substances) directive were prepared in 2014 by electronic product manufacturer associations (Digital Europe, TechAmerica and JEITA), with contributions from their members. Through these dossiers, producers ensure that they adjust to technical progress for chemical substance replacement.

REACH: In 2014, ten new substances were added to the other 151 already incorporated into the list of candidate substances for authorization within the framework of the European Regulation regarding chemical substances (Registration, Evaluation, Authorization and Restriction of Chemicals). The requirements concerning the restriction and declaration of substances are strictly respected by the Swatch Group companies and SGQM works with the industrial branches linked to watchmaking in order to ensure that all use of substances meets the authorization criteria established by the authorities. In 2014, nine substances were added to 22 others already on the authorization list (Annex XIV of REACH). A proactive substitution policy continues to be carried out where this is technically possible, which notably made it possible to forgo the use of chromates in production.

ICAO regulations: The International Civil Aviation Organization (ICAO) took a decision to tighten the requirements for the transportation of lithium metal batteries. This is now solely authorized by cargo aircraft. Organizational measures were undertaken by the Swatch Group companies in order to apply the new regulations.

CONTINUOUS IMPROVEMENT

RESULT Initiative: SGQM implemented a procedure (Responsibility of the Supplier for Lot Testing) which, using an Extranet site, provides Swatch Group suppliers with direct access to the legal and technical requirements for materials and testing methods. This new instrument enables optimization of product monitoring in the supply chain.

Standards and specifications: The evolution of technologies and watchmaking products requires periodic revisions or the creation of new criteria suited to consumer needs and future industrial processes. With this in mind, SGQM – together with the support of many internal experts – plays an active part in various Swiss (SN-NIHS), European (CEN) and international (ISO) technical committees.

REACH: Evolution of SVHC candidates + SVHC subject to the authorization for production according to Annex XIV
(SVHC: Substances of very high concern)

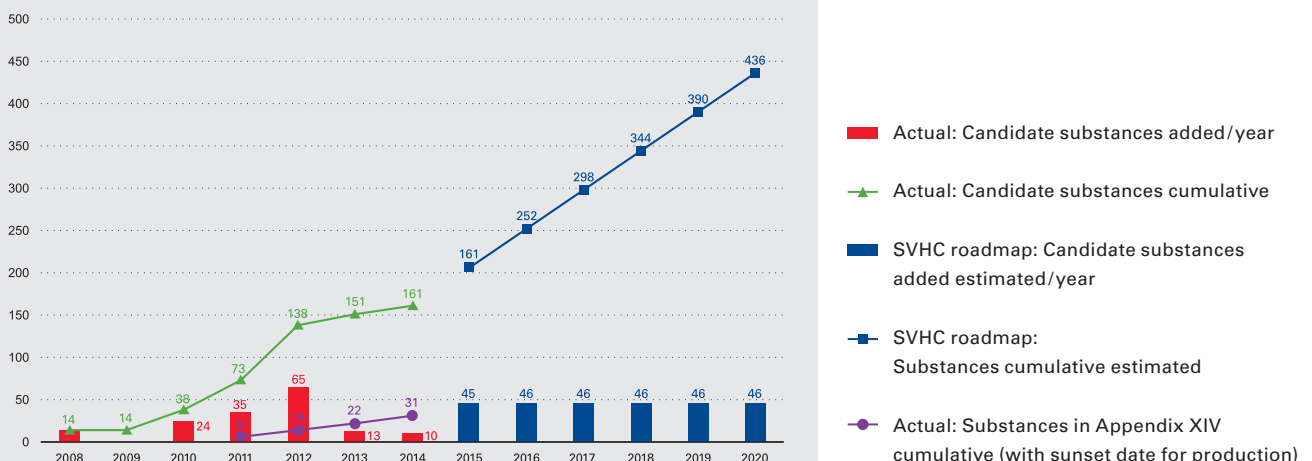



SWATCH GROUP SERVICES

DIVISION EUROPEAN DISTRIBUTION CENTER (EDC)

5

In 2014, European subsidiaries benefitted from the integration of a new service provider. While service quality was maintained at a consistent high level, significant savings on transportation costs were realized. In close collaboration with Swatch Group's brands and subsidiaries, EDC focused on activities and measures to improve logistics efficiency continuously, including order consolidation, improved shipping rhythm and data quality. The EDC warehouse in Biel/Bienne made improvements in internal processes. A new procedure to read information on RFID tags was set up and the handling process for e-commerce was streamlined, which will ultimately lead to better tracking and greater transparency in European countries. EDC constantly adapts its business models to offer potential new customers and countries a range of services enabling them to benefit from its products and synergies. Two new countries are currently under review.

DIVISION SWATCH GROUP LOGISTICS (SGL)

In 2014, the Swatch Group Logistics (SGL) division maintained its targeted efforts regarding improvements at the subsidiaries and the brands, whether they involved planning systems, logistics data management, improvements to productivity or the implementation of KPI (Key Performance Indicators) interfaces. The Replenishment Tool recently developed by SGL has either been implemented or is in the process of being implemented at several subsidiaries. Analysis reports were also developed and the synchronization of order portfolios was finalized. Finally, LIROS (Logistics, Information and Replenishment Ordering System) and WLI (Weekly Logistics Information) systems are currently being adapted.

The SGL division also implemented a warehousing and order processing solution for the new Swatch Group subsidiary in Indonesia. It continued to use support tools for logistics depot creation at the subsidiaries, as well as for the delocalization of infrastructures, in order to accompany, adapt and optimize the process according to local market growth. Certain activities enabled improvements to transport solutions depending on product type. Finally, a new planning system is now operational for one brand, while it is being implemented for others, using the same model.

DIVISION SWATCH GROUP IT SERVICES

6

Swatch Group IT Services continued to work closely with the IT departments of Swatch Group companies worldwide to better correspond to the growing business requirements. Its teams managed about 120 support calls daily and served more than 5200 SAP users and almost 9000 IT workplaces worldwide. The Distribution IT, SAP Competence Center, IT Energy, E-Commerce, Application Development Services, Retail and IT Operations Departments worked on several projects in various domains of enterprise resource planning including logistics and customer service for Glashütte Original, Harry Winston, Swatch Group China, France, Japan, Macau and others. The new Application Operation Department also supported brands in their retail and e-commerce activities by enhancing mobile accessibility of e-commerce and deploying solutions in different countries. The newly-implemented network acceleration technologies enabled secure video and telephone conferences through the corporate network as well as the internet and enabled the provision of cost-effective support on demand to the subsidiaries remotely from Switzerland. Other important projects during the past year were the Olympic Winter Games and Baselworld.

DIVISION SWATCH GROUP CORPORATE CUSTOMER SERVICE (CCS)

8 / 9

The Swatch Group Corporate Customer Service (CCS) division aims to improve the quality of the services provided to the customers. It supports brands' and subsidiaries' Customer Service (CS) teams in their development initiatives, to grow more efficiently while benefiting from corporate synergies. This has a direct and significant effect on achieving services at high quality levels and generates customer satisfaction that impacts the brands' image and reputation.

Swatch Group Subsidiaries and Brands: The continuous development of the markets requires constant evolution of the CS centers. From ideation to implementation, the CCS shares its expertise and helps CS players realize their projects. The China CS strategy was reviewed while the service center in Beijing was moved and the one in Shanghai was expanded. The service centers in Mexico and South Africa moved into new premises according to a new layout organization; the service center in Sweden was relocated, while those in South Korea and Southampton UK were expanded. Customer Service at the Longines headquarters was expanded, reconfigured and completely redesigned. The first Customer Care handbook was compiled meeting best practices and supplying useful resources by combining the experience of the brands, subsidiaries and CCS.

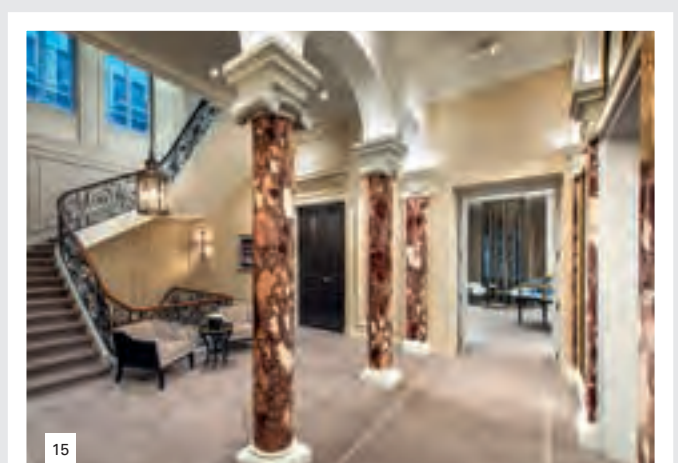



Schools and training programs: In Shanghai, the first class of students following the one-year watchmaking course concluded their training while the Hong Kong school welcomed its first one-year course students at the beginning of 2014. The Swatch Group-certified six-week technician training courses, which enable company employees to perfect their skills in movement exchange techniques, polishing, diagnostics and quality control, were further developed. The Chinese and European Standard Diagnostic & QC Technician pilot courses were successfully completed.

Selective Spare Parts Distribution (SSPD): The program for SSPD, which aims to improve the quality of services for the end customer, was deployed to all European countries with a Swatch Group subsidiary.

IT systems: The most recent developments concerned the integration of customer relations management in the Division's systems and processes. The aCSis customer service program was enhanced with new functions that optimized customer communication.

DIVISION REAL ESTATE DEVELOPMENT

10 / 11 / 12 / 13 / 14 / 15

In 2014, the Real Estate Development Division was characterized by extensive activity with Swatch Group companies both in Switzerland and abroad.

The process of modernizing the real estate portfolio and improving the infrastructure continued, notably at Longines in Saint-Imier (BE) with the implementation of a logistics building and facilities, as well as at Rado in Lengnau (BE), Tissot in Le Locle (NE), Nivarox-FAR in Fontaines (NE), Comadur at Col-des-Roches (Le Locle, NE), MOM Le Prélet at Les Geneveys-sur-Coffrane (NE), and in Biel at Omega, Hamilton, Swatch Group and Swatch Group Services. This work was part of a policy aimed at improving workplace safety and supporting such values as the consolidation of the sustainability of the production facilities. It also stemmed from a desire to optimize and vertically integrate production flows to improve infrastructures for increased product quality, thus concretizing a policy to reduce consumption of fossil and electric fuels.

A number of large-scale projects continued. The project under construction for the Universo and Rubattel et Weyermann buildings in La Chaux-de-Fonds (NE), totalling 45000 square meters, went into production in summer 2014. Implementation of the project at the Omega and Swatch site in Biel/Bienne also began, which in time will result in the construction of a 50000 square-meter surface area. For the Swatch Group companies' industrial park in Boncourt (JU), work began on a second stage that will result in a 25000 square-meter production building.

The Real Estate Development Division also carried out its consulting activities, feasibility studies and design development with the various Swatch Group subsidiaries and brands, coordinating the participation of the latter at Baselworld with the creation of stands amounting to a total of more than 10000 square meters of exhibition and sales space.

Finally, specialists in the Real Estate Development Division contributed to developing or renewing the vast boutique network for Swatch Group's most prestigious brands – and in particular for Breguet in Kuala Lumpur, London and Paris, and for Harry Winston in Cannes, Hong Kong, Honolulu, Las Vegas, Paris, Rome and St. Moritz (GR) – as well as for Tourbillon in Lugano (TI) and the Hour Passion shops in Las Vegas, Łódź, New York and Poznań.

SWATCH GROUP IMMEUBLES

www.swatchimmo.ch

Swatch Group Immeubles' year was characterized by intense activity in the management of a large rental base consisting of more than 5000 rental or farming properties, mainly in the cantons of Berne, Jura, Neuchâtel, Solothurn and Vaud.

The company manages the real estate that is part of the Swatch Group Pension Fund and Fondation d'Ebauches SA, as well as other employer pension funds and several affiliated companies. During the year, its real estate management focused on close monitoring of renovation and sanitization work, as well as brokerage agreements that Swatch Group Immeubles successfully managed on its clients' behalf. This positive development helped reduce the number of objects for rent as well as brokerage agreements that had reached maturity. The company intends to continue advising its clients on real estate matters and on follow-up in the implementation of real estate operations.

SWATCH GROUP

IN THE WORLD



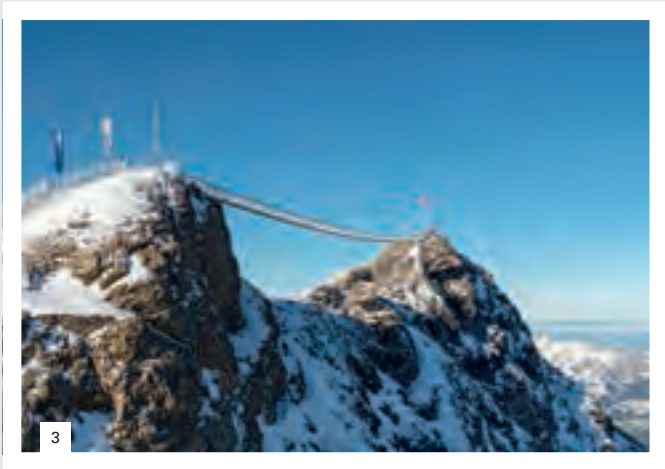

SWISS MARKET

1 / 2 / 3 / 4

In Switzerland, Swatch Group acquired one of the most emblematic buildings on Zurich's Bahnhofstrasse in late 2014. It is the Peterhof, a historic gothic revival building, whose construction was completed in 1913. Located at number 30 on the renowned Zurich street at the corner of Paradeplatz, it is the first commercial building in the direction of the main station and includes 7435 square meters of retail and office space.

In 2014, the Swatch Group brands and retailers continued to develop in the Swiss market, in particular with regard to their activities in the prestigious Tourbillon network, as well as in the Hour Passion, Omega and Swatch boutiques at Geneva Airport, and in the spaces operated in partnership with Manor. Tourbillon renovated its Lugano (TI) and Crans-Montana (VS) boutiques. The brands boosted their presence throughout the year.

Breguet presented a traveling exhibition devoted to its innovations and a special display theme dedicated to silicon and high frequency. The brand hosted wine and fine watch enthusiasts at its boutique in Zurich during the Zürcher Spring Tastings, as well as at the Geneva boutique during the Vendanges de Genève, and at its Gstaad (BE) boutique as part of the Promenade Gstaad Party. It renewed its partnership with the Geneva International Music Competition and partnered with the Mezzo television station for transmission of the 2014 edition. Opened in late 2013, the Harry Winston Salon in Geneva experienced a positive first full year, enticing Swiss and international visitors in search of exceptional high jewelry. Blancpain won the Grand Prix d'Horlogerie de Genève for its Women Heure Décentrée Seconde Rétrograde. Glashütte Original also took part in the Vendanges de Genève in conjunction with Jaquet Droz at their joint boutique on the Rue du Rhône. Wine glasses in hand, guests discovered the art and refinement of timepieces made in Saxony. Jaquet Droz, which enjoyed a record year, stirred considerable wonderment with its Ateliers d'Art and its partnership with the Béjart Ballet Lausanne. Omega focused its communication on its Master Co-Axial technology. Title sponsor of the European Masters, the brand organized a golf tournament for its retailers and invited its partners to the Weltklasse Zürich athletics meet in its capacity as official timer.

Present at the Zurich leg of the Longines FEI World Cup™ Jumping, at the CSI Basel and the CSIO in St. Gallen, Longines also acted as official timer for the Lausanne leg of the Global Champions Tour, as well as for the events at the Alpine Skiing World Cup in Wengen (BE) and Adelboden (BE), and for the finals held in Lenzerheide (GR). It took part in the final of the archery World Cup in Lausanne as well. Rado signed a partnership with the Swiss Indoors Basel tennis tournament, during which the brand was present on the center court with its corner clocks, and also as on Swiss television with a tennis themed clip and presenting its HyperChrome Court Collection.

Strengthening its position as a leader and pioneer, Tissot recorded another year of record results and launched its Tissot T-Touch Solar. The brand inaugurated the "Peak Walk by Tissot", the first suspension bridge in the world between two peaks, as part of its partnership with Glacier 3000. The opening of the first Tissot boutique in Switzerland, on the Bahnhofstrasse in Zurich, was one of the highlights in 2014 as was the integration of a new boutique in one of the biggest department stores of Geneva, which was celebrated with brand ambassador Thomas Lüthi.

For Balmain, the highlight of the year was the election of Miss Switzerland 2014, Laetitia Guarino, who became an ambassador of the brand. Certina recorded an exceptional year, undertaking various activities to increase its reputation. Investing in communication, Mido strengthened its position and once again enjoyed a record year. Partner to the Swiss Aerobatics Champion-

ship 2014, Hamilton also saw its watches make a return to the big screen in *Der Koch (The Chef)*, a Swiss film based on the novel by Martin Suter. Calvin Klein watches + jewelry had an excellent year and continued to expand its shop-in-shop network and improve its presence, strengthening its position as a leader in Swiss-made fashion watches.

Swatch was the title sponsor for Swatch Rocket Air, in which Swatch Proteam member Sam Pilgrim took part, and inaugurated its first flagship boutique in Switzerland, with 91 square meters on the Bahnhofstrasse in Zurich featuring a brightly colored design. The new Irony XLite was launched in a Swiss preview for the local market, accompanied by a campaign featuring the new Swatch ambassador: the XLite robot. Events for Gold & Pioneer members of the Swatch Club took place in Geneva and Zurich.

SWATCH GROUP GERMANY

5 / 6 / 7 / 8

Swatch Group Germany enjoyed an excellent, success-filled year in 2014, making the expansion of shop-in-shop capacity and the concentration of distribution its priorities.

Breguet presented an exclusive selection of watches at a special exhibition in Frankfurt, while Blancpain held a Ladies' Night in its Munich boutique and was presented at a series of automobile races at Nürburgring. Glashütte Original celebrated the launch of its new Caliber 37 for chronographs with an event in Dresden. Jaquet Droz fascinated its clientele with its special decoration at the Tourbillon boutique in Baden-Baden. Omega held an exhibition at Berlin department store, KaDeWe, in partnership with the GoodPlanet Foundation, and became the principal sponsor of the Deutscher Filmball. Longines hosted Steffi Graf in Frankfurt, where the brand ambassador gave a number of exclusive interviews and took part in an autograph session.

Rado held a meet and greet session with its two ambassadors, Agnieszka Radwańska and Julia Görges, at the Porsche Tennis Grand Prix. For the first time, Union Glashütte sponsored the Camaro driven by Tomaz Enge and Prince Albert von Thurn und Taxis at the ADAC GT Masters. Tissot awarded a special prize at the Frankfurt Grand Prix cycling classic and organized an event during the MotoGP where guests met brand ambassador Stefan Bradl. Handpicked Certina guests took part in an exclusive VIP weekend as part of the World Rally Championships. Mido focused on special decorations in frontline positions in Berlin and Munich. Hamilton presented its new collection to a panel of journalists at a press lunch in Munich, while Calvin Klein watches + jewelry distinguished itself in Berlin with highly effective special decoration. Swatch presented its SISTEM51 in Munich and inaugurated its first flagship boutique in Hamburg. Flik Flak launched its new collection at an event in Munich.

SWATCH GROUP AUSTRIA

9 / 10 / 11

In 2014, Swatch Group Austria continued to improve the quality of its operations and to optimize its distribution. Breguet's visibility improved thanks to the activities in its boutique in Vienna. Glashütte Original consolidated its market share and optimized its retailer network. Omega once again enjoyed highly positive development in the market, with highlights including special events for clients at its Vienna boutique, including an informational evening dedicated to Master Co-Axial and a visit by brand ambassador, Bastian Baker. Longines strengthened its position thanks to its presence at national events such as the Alpine Skiing World Cup trials and the Longines Global Champions Tour. Rado partnered the Vienna Design Week and was Official Timekeeper of the Erste Bank Open tennis tournament, won by brand ambassador Andy Murray. In November, Rado's Vienna boutique was refurbished in line with a new design concept. Partner to the Silvretta Classic Rallye, Union Glashütte focused on the acquisition of new clients and the organization of events at retailers. In 2014, Tissot focused on large-scale POS presentations, winning new market share. Certina recorded double-digit growth and strengthened its position, especially in eastern Austria. Calvin Klein watches + jewelry once again partnered the Elite Model Contest and organized an event to present its new releases. Increasing the number of its wholly-owned boutiques, Swatch inaugurated a new shop in a prime location in Salzburg. Flik Flak focused on the back-to-school and Christmas periods.

SWATCH GROUP BELGIUM

12

All Swatch Group Belgium brands continued to strive to improve the quality of their distribution and also organized innovative marketing activities and special events. Breguet hosted an array of eminent Belgian personalities at the Cercle de Lorraine for an event retracing the history of the watchmaking industry from the 18th century to the present day. Blancpain once again made the Spa-Francorchamps Endurance Series the highlight of the year. Omega was present at the Best Dressed Man 2014 competition and conducted an advertising campaign in both the media and on the Internet throughout the year. The Longines Global Champions Tour started in Antwerp at the end of April, followed by other prestigious show jumping events title sponsored by the brand. Rado had a highly successful year with the HyperChrome collection and effective communication. Tissot strengthened its position as leader in its segment with several new shop-in-shops. Elected Miss Belgium 2014, Laurence Langen became the Balmain ambassador in Benelux. Highlighting its new image among its retailers, Certina once again had an excellent year. Hamilton continued the expansion of its distribution network. Calvin Klein watches + jewelry focused on its presentation in the points of sale. Swatch enjoyed a remarkable year thanks to its partnership with Art Brussels and the opening of its megastore next to the famous Grand-Place in Brussels. Our friends Flik and Flak continued to have fun teaching children how to tell the time.

SWATCH GROUP NETHERLANDS

13 / 14

In Netherlands, Omega partnered with the Best Dressed Man Award 2014. Longines created brand awareness in the domestic market through corporate and local events. Rado launched the Esenza Ceramic Touch at a Dutch Design venue in Amsterdam. Union Glashütte and Mido made their entrance in The Netherlands. Tissot launched its online shop. Miss Belgium 2014 became the new ambassador for Balmain in Benelux. Certina gained market share and realized extensive growth. Hamilton sponsored the Volkel in de Wolken Hamilton Airshow and the national Rembrandt Cinema Awards. Calvin Klein watches + jewelry concentrated on its distribution network with a tailor-made window campaign offering extra visibility. Swatch opened an impressive 60 square-meter concept store at De Bijenkorf Amsterdam and organized successful events for the Pastry Chefs, Scuba Libre and SISTEM51 collections as well as for the Swatch Club watch. Flik Flak launched several successful online promotions.

SWATCH GROUP LUXEMBURG

During 2014, Swatch Group Luxemburg's companies further assisted Swatch Group's international growth with their support activities by providing their services in the areas of operation financing, liquidity management and optimization of insured risk, this in a still challenging and volatile financial market environment. Located in the financial heart of Europe, Swatch Group Luxemburg benefits from the vast range of services provided by an internationally recognized and efficient banking and insurance system, which is regulated and supervised by national and European authorities.





15



16



17



18



19



20



21



22

SWATCH GROUP FRANCE

15 / 16 / 17

The daring approach practiced by Swatch Group France in 2014 was a big hit, creating a buzz throughout Paris from the beginning of summer until Christmas.

It all started with an advertisement in the national media about its partnership with the Automobile Club de France, in the context of the renovation of the façade of the prestigious 18th century urban mansion that is home to this very select Parisian club on the Place de la Concorde. A dramatic turn of events in the world of French luxury, this one-year agreement occurred at a time when the Swatch Group brands had already enjoyed high visibility at the Conciergerie in 2011, the Louvre in 2012 and the Hôtel de la Monnaie in 2013. Swatch Group France thus once again achieved a major coup. A prestigious location symbolic of the French Revolution, the Place de la Concorde is one of the most visited places in Paris: its amazing size, obelisk, fountains and the magnificent buildings surrounding it make it a top tourist attraction and, due to its position at the very heart of the French capital, a regular transit point for Parisians.

Occupying 400 square meters on the Place de la Concorde is the perfect way to generate exceptional visibility in a top-notch location and the brands understood this very well! Swatch "got the ball rolling" with a candy pink visual, whose laid-back humor enchanted the media, which heaped praise on the brand's boldness. Tissot subsequently revealed its innovative solar T-Touch, prior to Omega casting a magnificent shadow, caused by the Dark Side of the Moon, over the square. It was Blancpain, however, that made the greatest effort – widely acclaimed by the media and general public alike – to integrate its visuals into the environment, with its sharks intersecting Jacques-Ange Gabriel's *trompe l'œil* columns. Finally, Harry Winston lit up the month of November with a magnificent long sautoir necklace on a wintry blue background, prior to an ultra-thin Breguet Tourbillon appearing to celebrate Christmas on the square!

2014 thus finished off on a high note for the French subsidiary, with satisfactory financial results driven not only by a unique marketing outreach but also by a powerful selective distribution strategy backed by the active development of own-brand distribution.

SWATCH GROUP SPAIN

18 / 19

2014 was a very productive year for Swatch Group Spain. Breguet enhanced its strong musical legacy with its presence at the Royal Theatre. Blancpain reinforced its relationship with gastronomy at the *A Cuatro Manos* event in collaboration with the Tourbillon boutique. Glashütte Original opened a pop-up store at El Corte Inglés. During a golf tournament organized by Omega, Sergio García had the chance to meet clients and journalists. The year was an important one for Longines thanks to the six equestrian events that took place in the country throughout 2014. Rado organized a Touch Event for journalists. Tissot chose Valencia to host the international launch of the T-Race MotoGP 2015 in the presence of its President, François Thiébaud. Certina organized a media presentation around all of its collections. Hamilton organized a presentation for the press before Baselworld. Barcelona was the city chosen by Calvin Klein watches + jewelry for the introduction of its newest products. Swatch began the year with a very sweet presentation with renowned Spanish pastry chef Oriol Balaguer, who created a personal Swatch interpretation of *Charlie and the Chocolate Factory*. Flik Flak finished the year with a Christmas Party for journalists' children.

SWATCH GROUP ITALY

20 / 21 / 22

Breguet's "Innovations That Wrote History" exhibition was presented in Florence at the historic Palazzo Capponi. In December Harry Winston opened its first Salon in the Italian market on Rome's via dei Condotti. In October Blancpain welcomed dealers to the Il Salviatino resort in Tuscany with ambassador Gianluca Genoni. Glashütte Original and Jaquet Droz increased brand awareness, reinforcing their market positions and opening new shop-in-shops. Omega President Stephen Urquhart and ambassador Gene Cernan attended the opening of the Omega boutique on via Montenapoleone and announced a partnership with Museum of Science and Technology during the inauguration of a section devoted exclusively to space. Longines' successful blogger event with ambassador Jane Richard marked the brand's strong equestrian link. Media, VIPs and selected retailers discovered new and historic collections at an event in Milan. Rado strengthened its image and visibility with space in strategic locations and selected shop-in-shops. In September Tissot launched Tissot T-Touch Expert Solar in Milan's Museum of Science and Technology and announced a partnership with the Tinkering Zone. The Power of Light concept was expressed through a light painting performance. Hamilton partnered with the 68th edition of *Nastri d'Argento*, with a special prize given to director Pierfrancesco Diliberto, and also with Rome's International Airshow with special guest Nicolas Ivanoff. Calvin Klein watches + jewelry was back on Italian TV with a sophisticated and sensual spot. Swatch opened its new flagship store on Milan's via Montenapoleone with music star Mika as special guest for the ribbon-cutting and post-event private concert. Flik Flak started a very successful collaboration with Gardaland, Italy's biggest leisure park.

SWATCH GROUP UNITED KINGDOM

23 / 24 / 25

Swatch Group United Kingdom maintained a strong performance in a challenging market. Focusing on retail, new boutiques opened in prime locations and all brands improved existing stores and shop-in-shops. Breguet and Blancpain celebrated the opening of their beautiful flagship boutiques on Old Bond Street, hosting exclusive evenings for press and clients. Omega ambassador Rory McIlroy delighted guests, going straight from winning The Open to an annual golf event at Gleneagles for a private golf clinic. To celebrate the opening of its Oxford Street boutique, ambassador Cindy Crawford joined President Stephen Urquhart for a day of media activity ending with a VIP dinner at The Shard. Longines took center stage at the Glasgow 2014 Commonwealth Games as Official Timekeeper and equestrian sports continued to dominate at Royal Ascot and the Longines Global Champions Tour, which continued to wow guests at the iconic Horse Guards Parade. Rado ambassador Andy Murray stopped traffic as he arrived at Hour Passion Oxford Street for a personal appearance. The brand also invited retailers and press to enjoy hospitality at Queens where it was Official Timekeeper. Tissot focused on retail with its first UK boutique opening on Oxford Street. It also started its partnership as Official Timekeeper for the RBS 6 Nations rugby tournament. Certina highlighted its partnership with the Sauber F1 Team at the Hour Passion boutique in London with a Q&A session with driver Adrian Sutil. Hamilton demonstrated its aviation association as media joined ambassador Nicolas Ivanoff for a flying experience, and celebrated its placement in movie *Interstellar* with a private screening. Calvin Klein watches + jewelry launched a new boutique in Edinburgh and hosted a press event for its new collections. It was a busy year for Swatch, which announced an exciting partnership with the British Fashion Council working across the biggest events in the fashion calendar including London Fashion Week. The brand celebrated the launch of SISTEM51 at the newly redesigned Oxford Street store, opening doors to the public at 9.51 a.m. Flik Flak celebrated the 40th anniversary of Hello Kitty, delighting children who joined in the fun activities.

SWATCH GROUP IRELAND

26

Swatch Group Ireland continued to increase market share. Hour Passion opened a new store in the Dublin Airport Terminal. Longines continued to celebrate its association with equestrian sports at the Dublin Horse Show. Rado focused its marketing activities on the launch of the Rado DiaMaster and advertised on the Irish Times website. Tissot held an event in Arnotts, Dublin's oldest and largest department store, to promote its partnership with MotoGP, installing a bike simulator for shoppers. Swatch invested in an impressive outdoor campaign to promote SISTEM51 and took over prime retail windows in key locations in support of the Pastry Chefs collection. The brand also launched Scuba Libre by hosting an exclusive event for clients in Arnotts. Flik and Flak delighted children at key retail locations across Ireland for the first time.

SWATCH GROUP NORDIC**DENMARK**

27

Swatch Group Denmark's presence in the market again contributed greatly to increased market share in all price segments. Distribution quality improved in 2014 through constant focus on fewer and stronger points of sale. Omega participated in the Copenhagen Fashion Week AW2014 and successfully launched the new Seamaster 300 Master Co-Axial. Through the CSIO Horseshow in Odense, Longines reinforced its strong presence in national and international horse riding. Rado paid special attention to its educational program for retailers. Tissot and Certina focused on shop-in-shop installations with key partners, enjoying tremendous results. Calvin Klein watches + jewelry launched successful models. With its online public relations campaign for SISTEM51, Swatch generated buzz and interest.

FINLAND

28

In spite of a challenging economic environment in Finland, Swatch Group brands gained market share in every segment. Omega's Master Co-Axial demonstrated great potential thanks to its resistance to strong magnetic fields. The first ice hockey game between Tissot and its Finnish retailers was a resounding success. Certina's partnership with the WRC rally again enjoyed high visibility. The launch of the Swatch SISTEM51 generated considerable consumer interest.

NORWAY

29

Swatch Group Nordic developed the brands' market positions. Omega continued its Université of Omega training. Longines had positive sales growth. Rado continued to develop its new models successfully. Tissot T-Touch Solar models were well introduced and the brand served as timekeeper at the MTB WC in Hafjell. Certina benefitted from its partnership with Ole Einar Bjørndalen, named Best Male Athlete at the Sochi 2014 Olympic Winter Games. Calvin Klein watches + jewelry had strong development in the fashion segment.

SWEDEN

30

In Sweden, Omega remained one of the strongest prestige watch brands, with focus on distribution and strong marketing and public relations. Longines continued its support of equestrian sports with the Gothenburg and Falsterbo Horse Shows. Rado focused on the establishment of the HyperChrome family and the launch of the DiaMaster product line. Tissot had high visibility with additional store space, creative window decorations and historical mini exhibitions. Certina maintained its position as one of the strongest brands in its segment. The long-term commitment in motor sports continued with WRC and the Swedish Rally. Calvin Klein watches + jewelry had the best possible points of sales and a strong collection with great sell out. Swatch's main focus was on raising brand awareness through shop-in-shops in strategic locations.





30



31



32



33



34



35



36

SWATCH GROUP GREECE

31 / 32

In a challenging economic climate, Swatch Group Greece achieved excellent growth, focusing on optimizing its sales network, exploiting domestic opportunities and reaping the benefits of a well-organized seasonal market. Omega had outstanding sales both in the Athens boutique and its national distribution. Ambassador Training for retailers enhanced its image and position. Longines grew stronger in the domestic and the touristic markets with a focus on public relations activities, solid advertising and retail training programs. Rado realized successful launches of the Esenza Ceramic Touch and DiaMaster and refreshed its image throughout its POS network. Tissot's growth was supported by retail training, shop-in-shop openings, retail promotions and a launch event in Valencia (Spain) to which Greek retailers were invited. Hamilton increased brand awareness with its participation in the *Jack Ryan: Shadow Recruit* and *Interstellar* films, organizing media and retailer events around its relationship with the film industry. Calvin Klein watches + jewelry outperformed the competition with a solid commercial strategy and a carefully implemented, high-profile brand image in the POS, investing in shop-in-shop renovations and attractive merchandising. Swatch sustained its national retail network, successfully launched SISTEM51 and retained its leadership as a fashion brand. The Swatch Club significantly increased its membership.

SWATCH GROUP TURKEY

33

Swatch Group Turkey continued to consolidate the position of its brands in a growing, inflationary economy, partially influenced by political events in the eastern part of the country. Priority was given to the streamlining of the distribution and qualitative growth. Highlights were the opening of the first three corporate stores for Swatch and Calvin Klein watches + jewelry in Istanbul. The presence in travel retail supported the exploitation of the huge potential of tourists, particularly those visiting the southern area around Antalya. The successful takeover of the distribution of Longines at the beginning of 2014 was supported by the involvement in the 33rd World Championships of Rhythmic Gymnastics in Izmir. Preparations for the introduction of Hamilton and Balmain in 2015 were finalized. Further openings in 2015 of corporate stores in all price segments have been arranged. The customer service quality level is considered by consumers to be among the best in the country.

SWATCH GROUP POLAND

34 / 35 / 36

In 2014, Swatch Group Poland was particularly focused on the development of its proprietary distribution network by concentrating on strategic locations. Awareness of all the brands and image recognition was enhanced through targeted marketing activities, leading to the setting of ambitious goals for growth and success in the coming year. Two corporate multibrand retail stores were inaugurated: Hour Passion Łódź opened its doors in May at prestigious shopping mall Manufaktura. In August, Hour Passion Marszałkowska invited customers to experience its stunning, innovative watch concept on the busiest shopping street in central Warsaw. In late September, the high-end Omega boutique in a magnificent historic townhouse in the heart of Warsaw had a triumphant opening gala with brand president Stephen Urquhart and many Polish celebrities. Longines hosted major international sporting events in Poland, including the FEI Nation Cup in Sopot and Archery World Cup Stage 4 in Wrocław. Agnieszka Radwańska, top10-ranked tennis star and Rado ambassador, held a successful press conference in April. She also met fans at the Hour Passion boutique in Warsaw in December for a meet and greet session. The launch of the Tissot T-Touch Solar was held with great ceremony in the presence of brand president, François Thiébaud. A Calvin Klein watches + jewelry concept store, the very first in Europe, opened in October. Numerous events, VIP guests and celebrations highlighted the year.

SWATCH GROUP RUSSIA

37 / 38 / 39 / 40

In 2014, Swatch Group Russia continued to focus on the promotion of its brands, which once again enjoyed an excellent year and which, notably thanks to large-scale international events, consolidated their positions in the Russian market.

Breguet enjoyed a success-filled year, recording an exceptional increase in its sales and organizing a large number of events. In Moscow, the "Breguet, The Innovator" exhibition enabled the presentation of three authentic antique Breguet tourbillons; while in St Petersburg, the brand led two charity activities in the form of an auction and a concert, organized in support of the Artist Foundation, and in which stars from the Russian theatre world took part. Strengthening its position as a prestige brand, Jaquet Droz presented "The Enchanted Journey" exhibition at the State Historical Museum on Moscow's Red Square, a retrospective that was attended by more than 10 000 visitors in just a month. Omega had an intense campaign coinciding with the Sochi 2014 Olympic Winter Games, at which the brand was Official Timekeeper, and sponsored the "Designing 007: Fifty Years of Bond Style" at the Moscow Multimedia Art Museum. Omega also held an exhibition in Ekaterinburg, in conjunction with astronaut Alexey Leonov, to celebrate the 45th anniversary of the first lunar landing as well as a presentation of its Speedmaster Professional Apollo 11 "45th Anniversary Limited Edition" in tribute to the mission led by astronauts Neil Armstrong and Buzz Aldrin.

Events held by Swatch Group brands in Russia enjoyed first-class media coverage. In this respect, there were considerable returns from the presentation of the Longines Conquest collection at the famous GUM department store on Red Square as there was with Rado's sponsorship of the Kremlin Cup tennis tournament.

The mid-segment brands also very actively demonstrated their respective characteristics, putting considerable efforts into consolidating and extending their distribution networks and training sales staff, which contributed to increased sales and stronger images. Tissot enjoyed the benefit of excellent visibility thanks to its partnership with the Russian Ice Hockey Championships and to a travelling exhibition that visited the largest cities in the country. Certina promoted its commitment to the world of Formula 1. Hamilton held a presentation of vintage pieces in the Hour Passion boutique in Moscow.

For Swatch, 2014 was marked by the launch of Blossoming Love on International Women's Day with a kiosk at GUM and through the most recent Scuba Libre collection. The inauguration of the Swatch flagship boutique on prestigious Stoleshnikov Lane in Moscow constituted another highlight, as did the opening of a pop-up store dedicated to the SISTEM51, the first to be set up outside of Switzerland.

Finally, the implementation of a training center under the auspices of Swatch Group Russia customer service constituted a veritable milestone. The aim of this entity is to train watchmakers on site and to develop Swatch Group's own local skill-set.

All of these elements combined to create a solid basis for the future development of Swatch Group in Russia.

SWATCH GROUP USA

41 / 42 / 43 / 44 / 45

In 2014, Swatch Group USA reached a milestone of 100 retail locations in operation.

Tourbillon strengthened its US presence with the addition of a boutique in Houston, bringing the number of retail stores to nine. Hour Passion celebrated the store opening in Aria Resort & Casino, Las Vegas with tennis legend and Longines ambassador, Stefanie Graf. NBA All-Star and Tissot ambassador, Tony Parker, visited Hour Passion 34th Street, New York.

Breguet and the Fine Arts Museums of San Francisco announced their preparations for an exhibition comprised of the largest collection of timepieces and measuring instruments ever seen in the Americas. Blancpain relocated its New York flagship boutique to Fifth Avenue and opened its second boutique in the US shortly after at the Forum Shops at Caesars in Las Vegas. Glashütte Original presented a new exhibit, "The Art of the Chronograph", featuring the new movement, Caliber 37, which premiered in New York City and Chicago. To celebrate its 275-year history, Jaquet Droz brought "The Enchanted Journey" exhibition to Las Vegas, displaying some of the brand's most historic pieces. Omega launched the Speedmaster Dark Side of the Moon with Patrick Wilson, Taylor Schilling, and Coco Rocha and celebrated the 45th anniversary of the first lunar landing with astronaut Buzz Aldrin, as well as with Teo Halm and Sergio Harford. VIP clients attended the PGA Championship, which featured a James Bond exhibit. Omega's retail network has now reached 31 doors.

Longines continued as Official Timekeeper and Watch of the Triple Crown and brokered new partnerships with The Breeders' Cup and the Saratoga Race Course. Longines supported show jumping with the first annual Longines LA Masters and The Hampton Classic. Rado continued its tennis involvement as Andy Murray competed at the Paribas Tennis Showdown in New York City. Fans also enjoyed a meet and greet session with Agnieszka Radwańska at Hour Passion and the Rado-sponsored The Taste of Tennis culinary event.

Tissot opened its first two boutiques in the US on Fifth Avenue and Wall Street and celebrated with brand ambassadors Tony Parker, Danica Patrick and Nicky Hayden. Tissot remains the Official Timepiece of Madison Square Garden and *Men's Health* Urbanathlon. Mido placed new shop-in-shops in retailers in New York City, Miami and Los Angeles and expanded distribution to new states, Pennsylvania and Nevada. Hamilton bolstered its position in aviation and cinema by sponsoring EAA AirVenture, watching the Hamilton plane at the Red Bull Air Races and celebrating the 8th Annual Hamilton Behind The Camera Awards. Calvin Klein watches + jewelry enjoyed double-digit growth for 2014, ensuring a strong platform for future success.

Swatch continued its story of Revolution with the launch of SISTEM51, which made its national debut this year. The brand also sponsored the Swatch Women's Pro Trestles and the Swatch Freeride World Tour, and opened a new store in Indianapolis.





SWATCH GROUP CARIBBEAN

46

Swatch Group Caribbean enjoyed a very successful year with most of its brands achieving record results. Omega opened new boutiques in Saint Thomas, Aruba, and Nassau. Longines continued its dynamic growth and opened its first Caribbean boutique on Sint Maarten's famous Front Street. Rado, Tissot, and Swatch opened additional boutiques in Saint Thomas, a major touristic destination, particularly for cruise ship passengers. Mido, Hamilton and Calvin Klein watches + jewelry also experienced very strong growth and concentrated their efforts on the quality and personalization of their distribution. The business aboard cruise ships also expanded in quality and performance. It included the introduction of new brands like Swatch as well as new boutique concepts for Omega and Longines on mega-ships like the *Costa Atlantica*. In the second half of the year, Swatch Group Caribbean integrated into its area of responsibility the majority of the brands in the Latin American market that had previously been represented from Panama.

SWATCH GROUP CANADA

47 / 48

Swatch Group Canada continued its strategy to ensure high qualitative visibility at both the distribution and POS levels, paving the way for a record-breaking year. Dynamic public relations and marketing resulted in greater brand awareness. Breguet strengthened its leadership and continued its growth. Selective distribution reinforced Blancpain's presence in the luxury segment. Glashütte Original launched its first boutique-in-shop. Jaquet Droz continued to raise brand awareness. Omega's successful new shop-in-shops secured a leading presence at the POS level. Its Vancouver boutique took center stage with its Sochi Event. Longines launched The Elegant Collection, which contributed to a solid gain in market share. Rado realized significant growth through strategic investments in shop-in-shops. Tissot continued its qualitative focus and launched the Tissot T-Touch Expert Solar collection with great success. Hamilton now has one-third of its distribution with the brand colors. Calvin Klein watches + jewelry began its distribution through Calvin Klein Inc. Swatch drew strong focus to its own retail network with the opening of stores in Laval and in Montreal's iconic shopping district.

SWATCH GROUP BRAZIL

49 / 50

2014 was a busy year for Omega in Brazil, as it invested energy in its strong relationships with customers and press at boutique events in São Paulo, Rio de Janeiro and Brasília. It also hosted Buzz Aldrin for a special week of activities in the country. Tissot reached a new level, becoming one of the two top Swiss brands in the Brazilian market, thanks to new high-end product participation and impeccable distribution. Mido celebrated the launch of the new Barocelli collection and its link to the beauty of the Galleria Vittorio Emanuele in Milan, recalling on this occasion that the brand was the official sponsor of the photography exhibition held in that Italian city, with evocative views of its architectural icons. The 80th anniversary of the Multifort was celebrated in style, rewarding Mido's leadership position in the automatic mid-price segment. Swatch's fantastic Concept Stores in São Paulo and Rio de Janeiro showed Brazil a new face of the brand.

SWATCH GROUP MEXICO

51 / 52

After 13 years of commitment to its spirit of innovation and excellence, Swatch Group Mexico moved to a new location with a striking state-of-the-art Customer Service department. Breguet reinforced its presence opening shops in Guadalajara and Cancún. Linked to *l'art de vivre*, Blancpain was official watch sponsor at the luxury world's Millesime event. Omega celebrated the opening of its fourth Mexican boutique in Cancún. At the successful Longines Handicap de las Américas, the winner was presented a Conquest Classic. As the indisputable master of high-tech ceramic and with the launch of the DiaMaster, Rado set its sights on the next level. In the presence of press and prominent clientele, Tissot launched the Tissot T-Touch Expert Solar Collection at the Swiss Embassy. Creating high expectations, the Mido Multifort commemorated its 80th Anniversary. Hamilton reinforced its position in the market by positioning itself in a strong distribution chain. Calvin Klein watches + jewelry open day for editors and bloggers, highlighting the new products presented at Baselworld 2014, received outstanding media coverage. With creative experience, strategy and retail expansion, Swatch opened a new store in a prestigious mall in Mexico City.

SWATCH GROUP AUSTRALIA

53 / 54 / 55

For Swatch Group Australia, the focus in 2014 remained on raising the distribution platform for all brands, resulting in positive quantitative and qualitative results. Breguet achieved exceptional growth in sales and distribution, enhancing its market presence with increased public relations, advertising activities and high-profile events. Blancpain experienced substantial growth by strengthening its retail presence, expanding its marketing and public relations activities and solidifying its *art de vivre* connection through a VIP event. Omega achieved strong sales growth; key focus was placed on events throughout the year and creative integrated marketing campaigns. In a year of strong growth, Longines announced an equestrian partnership as Official Watch and Timekeeper of the Australian Turf Club and launched a robust campaign to promote the brand. Rado focused on collection management, improved market presence, and increasing brand awareness. The national rollout of a Rado Ambassador Program had a positive impact on sales. Tissot improved its qualitative presence at retail with the rollout of new shop-in-shops in key locations. Sponsorship of the Australian Football League and the title sponsorship of the Australian MotoGP remained central to brand communications. In 2014 Calvin Klein watches + jewelry opened its first boutique in Melbourne and a kiosk concession operation in Myer Melbourne. It improved brand visibility and presence through branded shop-in-shop furniture, consistent training and increased public relations. Swatch expanded its retail operations, focusing on store openings in key locations and on travel retail for greater visibility at airport locations. The product highlight of the year was the launch of the SISTEM51 with broad-based marketing support.

SWATCH GROUP CHINA

56 / 57 / 58 / 59 / 60

The Breguet boutique in the heart of Shanghai was the first stop of the "Innovations That Wrote History" 2014 exhibition featuring some of the inventions that have forged the brand's identity for nearly 240 years. Blancpain, which was present in 42 stores in 27 cities in China, enhanced its "Innovation is our tradition" essence with the "Fifty Fathoms Ocean • Legends" exhibition and its partnership with The Historical Diving Society Hans Hass Award Committee. Celebrating modern women with the Pavonina collection and sharing the unique artistry of German watchmaking with Chinese consumers, Glashütte Original opened its third boutique in China. Jaquet Droz had a wonderful year with the development of a new market in Kunming and the expansion of Xintiandi boutique in Shanghai. Its partnership with the Béjart Ballet Lausanne kept it in the spotlight. Omega maintained its leading position in the Chinese luxury market thanks to innovative watchmaking, social responsibility highlighted by the partnership with Orbis International and sports timekeeping at the Nanjing 2014 Youth Olympic Games. Expansion of the Beijing Oriental Plaza and Swatch Art Peace Hotel boutiques enhanced the brand's image.

Longines furthered its leading position with a remarkable sales performance, supported by marketing efforts at the Longines Global Champions Tour of Shanghai and the 45th Artistic Gymnastics World Championships in Nanjing. Rado actively explored markets all over China with new flagship boutiques and launched its latest collections, leading the trend in high-tech ceramic watches.

As Official Timekeeper of the 17th Asian Games Incheon 2014, Tissot proudly launched its PRC200 Chrono Quartz Asian Games

Special Edition and the Luxury Asian Games LTD watches, which increased brand exposure and generated sales. In response to fast-changing lifestyles, Balmain interacted with customers on social media platforms. Its new Iconic collection was an immediate hit. Certina became widely known in China with the re-launch of its corporate identity and the influence of the DS Powermatic 80. Mido celebrated the 80th anniversary of the Multifort, which has one of its collections' longest histories. It opened a new boutique in Tianjin. The 3rd Hamilton Behind The Camera Awards took place in Shanghai. Known for its leading roles in aviation and cinema as well as its innovative timekeeping technology, Hamilton returned to the big screen in the epic adventure *Interstellar*. Calvin Klein watches + jewelry reinforced its position as a contemporary, iconic, urban, sensual and sophisticated brand through creative visual campaigns and key product launches.

Swatch achieved solid growth sustained by a healthy increase in retail, focusing strongly on retail culture, incentive plans, a standard operating system and a talent pool across some 23 cities. In addition to the fabulous launch of the Pastry Chefs Special, Scuba Libre and Full-Time Fun collections, the groundbreaking appearance of SISTEM51 turned the watch world on its head. Flik Flak's brand image was reinforced through presentations in Swatch stores and an emphasis on the development of children's ability to tell time and on safety features designed especially for children.

On October 31st 2014, a press conference was followed by the grand opening of the "Faces & Traces" exhibition, launched both inside the Swatch Art Peace Hotel and along the Bund in Shanghai to celebrate the third anniversary of the Swatch Art Peace Hotel. From noon to midnight, over 600 guests from all corners of the world visited this Swatch Group residence that, to date, has accommodated and inspired 139 artists from 34 countries. The historic hotel, with 20 varied programs, was filled with vitality, the spirit of fun and positive provocation. The "Faces & Traces" exhibition at the Swatch Art Peace Hotel opened to the public from November 1st 2014 to March 1st 2015.





61



62



63



64



65



66



67



68

SWATCH GROUP HONG KONG

61 / 62 / 63

In a very dynamic environment, Swatch Group brands continued their long-term investments in retail network expansion, staff training, improved operations and exciting opportunities in marketing and communications. Breguet invited watch enthusiasts to attend a watch presentation in the boutique, followed by a Collectors' Dinner. It also hosted a gala dinner with the Musicus Society to promote cultural collaboration through music. Blancpain organized a media luncheon, a VIP Cocktail and an exhibition of new Baselworld products in its boutique at 1881 Heritage. The new collection was presented by renowned actress Eliza Sam. Blancpain and Omega opened new boutiques at Hong Kong International Airport. In September, Glashütte Original joined Elegant Watch & Jewellery to host the "Art of the Chronograph" exhibition, presenting a range of chronographs that have been made in Glashütte (Saxony) since the late 19th century. To demonstrate the latest timepieces and the exquisite craftsmanship of automaton, Jaquet Droz sponsored The World in 2015 Gala Dinner hosted by *The Economist* at the JW Marriott Hotel, and became the event's Official Timekeeper. Omega held a VIP Luncheon to launch the Master Co-Axial Collection driven by anti-magnetic movements and an event at the Emperor Centre in Tsim Sha Tsui East with Jennifer Tse and Simon Yam. A second Omega boutique on Canton Road was opened just before Christmas.

Longines, for the third year, became the Title Sponsor and Timekeeper of Longines Hong Kong International Races and Longines Hong Kong Masters. Rado's new ambassador Tang Wei starred in the new advertising campaign photo shoot in Hong Kong, which was launched widely in many prime locations. Longines opened three boutiques and Rado opened a flagship store.

To celebrate Tissot as the Official Timekeeper of the 17th Asian Games Incheon 2014, events and roadshows were organized extensively and successfully. Balmain presented the Arabesque, which symbolized the remarkable beauty in sophistication and feminine elegance. Certina introduced the exclusive PreciDrive™ movement, strengthening the brand's positioning in the market. Mido enjoyed sustained growth in 2014. Tissot unveiled three flagship stores and Mido opened two more boutiques. Hamilton held promotional events for two Hollywood blockbusters, *Jack Ryan: Shadow Recruit* and *Interstellar*. A gala premiere of *Interstellar* was held in November. A life-size Hamilton plane was exhibited in Discovery Park, Tsuen Wan, showcasing the brand's aviation heritage. Calvin Klein watches + jewelry continued to deliver promising sales growth in retail channels; further expanded its distribution, two shop-in-shops were opened.

The voyage of discovery of SISTEM51 began with a pop-up store in the Swatch flagship store in Central, which generated excellent sales results and noise in the city. Swatch continued to unveil two more stores.

The first batch of 14 students graduated from the Hong Kong Nicolas G. Hayek Watchmaking School in December.

SWATCH GROUP MACAU

64

Swatch Group Macau saw extraordinary development with new and expanded resorts focusing on gaming, hospitality and shopping. The brands expanded their footprints through accelerated openings of corporate flagship stores supported by emotional marketing activities. Breguet, Jaquet Droz and Rado joined the "In Full Bloom" exhibition at the Shoppes at The Venetian Macao. Blancpain had billboards in Macau International Airport featuring the L-evolution and Women collections. Glashütte Original's latest masterpieces, including the Senator Chronograph, were presented at the Masters of Time event organized by the DFS Macau department store. To ensure the best shopping experience for Macau customers, Omega enhanced and expanded its boutique at The Venetian Macao.

Longines' strategic outdoor advertising campaigns supported business development; the brand added a POS. Rado invested in large billboards featuring the new advertising campaign with Tang Wei. Tissot and Swatch opened new stores at the Galaxy Macau resort. Balmain had constant expansion with encouraging sales growth. During the Macau Grand Prix, Certina promoted DS Powermatic through an outdoor advertising campaign. Mido achieved steady growth and opened two new POS at Fisherman's Wharf and Macau International Airport.

Hamilton strengthened its distribution network with a new POS. Calvin Klein watches + jewelry was promoted at Winman Department Store. The swirl of SISTEM51 went to Macau with a pop-up store staged in the Swatch store at The Venetian Macao.

SWATCH GROUP TAIWAN

65 / 66 / 67 / 68

Swatch Group Taiwan had positive growth thanks to its focus on retail development and improved distribution. Breguet presented the "Innovations That Wrote History" exhibition; the Marie-Antoinette No 1160 watch was displayed in Taipei for the first time. Blancpain opened a shop-in-shop and renovated two others and its Taipei 101 boutique's façade doubled in size. Glashütte Original presented the new Pavonina ladies' collection and invited retailers to a launch event in Beijing. Omega continued its distribution development, adding two boutiques. Successful events were held to launch the De Ville Butterfly. Longines had strong growth and opened a second corporate store in Taipei 101 in May; the museum collection exhibition opened in August. Rado generated quality media exposure and stimulated sales through investments in shop-in-shops and targeted advertising. Tissot gained market share by investing in shop-in-shops and boutiques and through strategic marketing campaigns and merchandising decoration. Mido had strong growth with the release of the Multifort Limited Edition Taiwan GMT. Hamilton teamed up with first-tier department store Mitsukoshi with a pop-up store and plane exhibition. Sixteen stores were renovated and two new ones were opened by Calvin Klein watches + jewelry. Swatch sustained solid growth through distribution and retail expansion. The Zhongxiao Road megastore opening event and SISTEM51 pop-up store enhanced visibility. Flik Flak enjoyed a strong presence on Children's Day and Christmas.

SWATCH GROUP MALAYSIA

72 / 73

Swatch Group Malaysia kicked off the year well, benefiting from a strengthened distribution platform thanks to its quality network of corporate boutiques. Sadly, two unprecedented aviation disasters in March and July caused drastic declines in tourist arrivals, especially from China. Despite the turbulent conditions, which greatly weakened Malaysia's tourism industry, the company continued to focus on long-term strategies to increase its domestic clientele and posted reasonable growth for the year. The grand opening of Breguet's majestic flagship store in Starhill Gallery in May was attended by the brand's Museum curator, Emmanuel Breguet. In the same month, Blancpain co-hosted the Asia series kick-off of the Lamborghini Blancpain Super Trofeo 2014, featuring 28 drivers from ten different countries. By June, Omega had completed a major facelift of its boutique in KL Pavilion and presented its new products at Marini's-on-57 in the Kuala Lumpur City Centre (KLCC). The grand opening event of Longines' second boutique in prestigious Suria KLCC welcomed brand ambassador Eddie Peng and drew huge crowds of fans in November. Rado sponsored the increasingly popular ATP 250 Malaysia Tennis Open in September, which had a record number of viewers. Tissot held a series of roadshows in conjunction with the 17th Asian Games Incheon 2014 for which the brand was the Official Timekeeper. Swatch successfully launched the highly anticipated SISTEM51 collection in the third quarter of 2014.

SWATCH GROUP SINGAPORE

69 / 70 / 71

Despite difficult trading conditions in 2014 due to falling tourism numbers after the Malaysian aviation tragedies and the political crisis in Thailand, in addition to a resilient local currency, Swatch Group Singapore persevered with continuous marketing activities and the strengthening of its retail network in order to increase its brands' market share with local clients. Select watch collectors were treated to an evening cocktail at the Breguet Marina Bay Sands boutique to view the brand's latest timepieces. Blancpain impressed VIPs and media with its Baselworld 2014 collection presented in a heritage-rich mansion setting. Omega celebrated beauty and femininity in luxury horology with an evocative exhibition at Ion Orchard. Longines Singapore Gold Cup returned for its fifth run at Singapore Turf Club, with His Excellency, President Tony Tan Keng Yam and Eddie Peng, Longines Ambassador of Elegance gracing the event. Media partners were invited to preview the first Rado Esenza Ceramic Touch watch while being pampered with a relaxing manicure session at the new Marina Bay Sands Store. Tissot celebrated the 17th Asian Games Incheon 2014 with roadshows in leading malls to showcase its limited edition watches. Mido strengthened its brand positioning with exciting window animations and billboards along Orchard Road. Hamilton's *Interstellar* movie campaign created a great buzz on the featured watch. Swatch's SISTEM51 was a huge success when the collection was launched at the brand's megastore on Orchard road.

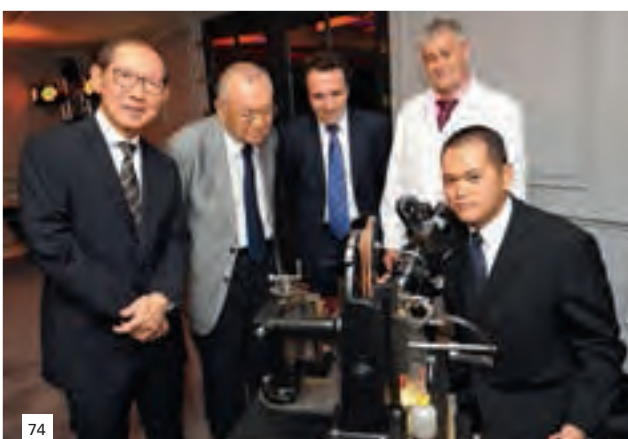



76



77



78



79



80



81



82



83

SWATCH GROUP THAILAND

74 / 75

After enjoying phenomenal sales in 2013, Swatch Group Thailand faced a challenging market in 2014 in view of the political turmoil that struck the country in the first half of the year. Breguet hosted The Art of Breguet Astonishes Bangkok in June, where more than 100 VIP guests discovered the brand's craftsmanship. The focus was on decorative dials through an exclusive demonstration of the art of cameo carving and engine-turning by hand. In October, Omega celebrated the 45th anniversary of the first lunar landing with the launch of the Speedmaster Apollo 11 45th Anniversary Limited Edition at an event at Siam Paragon square. Guests were treated to a sumptuous dinner under the stars as Thailand's top musicians performed for them. Longines held a customer event with local luxury retailer Pendulum at Central Chiangmai in November, highlighting the brand's history and promoting The Longines Heritage Collection. As official timekeeper of the 17th Asian Games Incheon 2014 in South Korea, Tissot invited leading Thai media to an exclusive behind-the-scenes tour of the timekeeping facilities. Calvin Klein watches + jewelry opened its first corporate kiosk in July at Central World and Swatch introduced its groundbreaking SISTEM51 collection in the second half of the year.

SWATCH GROUP SOUTH KOREA

76 / 77 / 78

Swatch Group South Korea enjoyed another record year with success driven by the continuous improvement of its quality distribution and by strategic marketing. Breguet reinforced its exclusive position through high-complication watches and the "Art of Watchmaking" exhibition. Blancpain's "The Women of Grace" exhibition showcased the brand's glamour and a new boutique in Galleria delivered solid results. Omega had one of the market's best performances. It celebrated the De Ville Butterfly collection at a high-profile event with Nicole Kidman in Seoul. Longines achieved exceptionally good sales in every channel, opening two boutiques in major department stores. Rado's streamlined distribution and its first South Korean boutique communicated its premium image. Tissot set a sales record despite fewer retail addresses. It served as the 17th Asian Games Incheon 2014 Official Timekeeper and maximized brand exposure through two pop-up stores in trendy areas and the use of brand ambassadors like fencing gold medalist Kim Ji Yeon. Mido achieved remarkable sales growth with dynamic road-show exhibitions in department stores. Hamilton celebrated its strong presence by launching the Seoul Limited Edition watch with actor and brand ambassador Daniel Henney. Calvin Klein watches + jewelry strengthened its positioning and identity through the Discover 2014 event. Swatch successfully launched SISTEM51, affirming its image as an innovative and creative Swiss watch brand, earning excellent feedback, and opening its second megastore. Two new Hour Passion boutiques opened in the fourth quarter, introducing its concept to excited South Korean consumers.

SWATCH GROUP JAPAN

79 / 80 / 81

Swatch Group Japan had a record year in 2014. Riding on the wave of an exceptional first quarter for the luxury segment, the brands continued to gain market share month after month in all price segments. Exciting new products communicated through high-scale events and innovative marketing campaigns formed the basis of Swatch Group's success in the country.

Prestige brands enjoyed outstanding sales growth, particularly in their Nicolas G. Hayek Center boutiques. Breguet and Glashütte Original renovated their boutiques with their latest concepts, treating VIP guests and the Japanese media to successful events. At one, top actress Dan Lei presented the Breguet Les Volants de la Reine high jewelry collection to an admiring audience. An upscale event in collaboration with Château Robuchon contributed to the Blancpain's outstanding performance. In the 150th anniversary year of the trading relationship between Japan and Switzerland, Jaquet Droz invited more than 200 guests to a sumptuous performance by the Béjart Ballet Lausanne at the NHK Hall in Tokyo.

Omega started its Olympian record year in Japan by welcoming top Olympic athletes to the Nicolas G. Hayek Center for a well-attended press conference ahead of the Sochi 2014 Olympic Winter Games. The brand continued to gain market share throughout the year, which culminated in a ground-breaking event for the launch of its new antimagnetic Master Co-Axial calibers. On a scale rarely seen in Japan, more than 200 guests, including top celebrities, gathered 30 meters underground to celebrate this major innovation in the cave location of the Oya Stone Museum on the outskirts of Tokyo.

Longines had an outstanding year that peaked on November 30th 2014 with the Japan Cup in association with Longines in the presence of more than 100 000 spectators and brand ambassador Lin Chi-ling. The event enhanced the brand's image in Japan. Rado successfully partnered with the Rakuten Japan Open Tennis Championships and tennis amateurs and fans enjoyed the new Rado creations.

Tissot continued its growth, and started its successful year with a well-attended exhibition at the Tokyo Contemporary Museum. The successful launch of the Tissot T-Touch Expert Solar contributed to the brand finishing the year in style. Hamilton, Japan's leader in its price segment, had a dedicated event for women. Over 150 magazine editors and bloggers enjoyed the world of Hamilton at Tokyo's trendy, newly-opened Andaz Hotel. Calvin Klein watches + jewelry concentrated its efforts on organizing in-store promotions, to the delight of its customers.

Finally, it was a great year for Swatch with the long-awaited launch of SISTEM51, which had a tremendous success in the market thanks to a perfectly-timed marketing campaign. SISTEM51 pop-up stores opened in Tokyo and Osaka, thrilling Swatch fans who lined-up to get their latest Swatch.

SWATCH GROUP INDONESIA

82 / 83

Swatch Group Indonesia was incorporated in March 2014, making it the first fully-owned subsidiary of a Swiss watch company in Indonesia. Six brands have joined the subsidiary so far. The core aims are to strengthen and elevate the brands' messages, positioning and market penetration, while broadening and deepening the distribution networks.

The subsidiary forms the operating core with fully functioning departments; a customer service division will be integrated in 2015 to provide state-of-the-industry quality services to Swatch Group's expanding customer base throughout Indonesia.

An enthusiastic, energetic, focused team has been assembled to enhance brand strategies, streamline the distribution channel of quality independent retailers and to lead the market to excellence. In line with these, Certina was newly launched in October and additional brands will be integrated in the years to come.

SWATCH GROUP INDIA

84 / 85 / 86

Swatch Group India increased sales in challenging economic conditions with continued focus on qualitative distribution, new POS and retail along with exciting marketing and public relations campaigns. Breguet, Blancpain and Jaquet Droz organized shared exhibitions of exquisite masterpieces in Delhi, Mumbai and Chennai for watch *aficionados*. Breguet and Blancpain entered the Mumbai market with two shop-in-shops each while Jaquet Droz had one. Breguet continued to hold its leadership position in its segment. Omega, with brand ambassador Abhishek Bachchan, celebrated the launch of the Speedmaster Dark Side of the Moon watch and the Speedmaster legacy at a glittering evening in Chennai. Along with opening two boutiques in Kolkata and Pune, Omega held a blogger meeting and several boutique activities to showcase new collections to VIP customers. Longines opened ten shop-in-shops and conducted media events in Hyderabad and Chennai to launch The Longines Elegant Collection. The brand's second boutique in Mumbai was inaugurated by ambassador Aishwarya Rai Bachchan. Rado opened five new boutiques and organized well-attended launch events in Delhi with brand ambassador Hrithik Roshan for DiaMaster and Lisa Ray for Esenza Ceramic Touch. Exhibition of Rado watches in smaller cities helped build awareness. Tissot opened three new boutiques and is now present in 268 POS. Extensive media coverage was generated through store visits by brand friends in metro and tier two cities. Balmain, now in 70 POS, conducted its first national training program with awards for sales excellence. Calvin Klein watches + jewelry, available in 190 POS, showcased its latest watch and jewelry collection to key media and retailers in Mumbai at its first event in India. Swatch held interesting and innovative events to launch the Pastry Chefs, Fall Winter and Big Classic collections. There was continued focus on qualitative distribution, improving store productivity and customer activation events in the major malls.

SWATCH GROUP MIDDLE EAST

87 / 88 / 89

Swatch Group Middle East had an excellent year, as brands strengthened their positions in their respective segments with focused distribution and strategic marketing.

Breguet remained the clear leader in the prestige segment and demand for its products far exceeded supply. The United Arab Emirates (UAE) flagship boutique in the Dubai Mall was refurbished to reflect the brand's latest concept. Harry Winston increased its visibility, bringing its magnificent jewels and innovative timepieces to new luxury audiences. An event in Kuwait highlighted the Bridal Collections, confirming the brand's position as the ultimate destination for diamond engagement rings. Blancpain's Fifty Fathoms collection was well received by high-end connoisseurs and diving enthusiasts. Highlights displayed in the Dubai Aquarium & Underwater Zoo attracted many visitors. Glashütte Original launched the Caliber 37 and boutiques in Dubai were among the first retailers to offer chronographs equipped with this innovative creation. Awareness of Jaquet Droz was raised by the installation of new shop-in-shops. VIP visitors were delighted by an enamel painting workshop. Omega strengthened its market leadership position with the opening of its first boutique in Jordan. It also extended its title sponsorship of the Dubai Desert Classic and Dubai Ladies Masters to 2017.

Longines continued to build its presence with the openings of boutiques in the region. It was also the Official Timekeeper of the Longines Global Champions Tour final stage, the first leg of the Furujiyya FEI Nations Cup and the HH Sheikh Mohammed Bin Rashid Al Maktoum Endurance Cup. Rado renewed its partnership with the Mubadala World Tennis Championship for another three years and also celebrated the launch of the eye-catching DiaMaster collection and continued its strong partnership with Rivoli.

Mid-price market segment leader Tissot upgraded its distribution network, rolling out flagship boutiques in the UAE and new generation shop-in-shops across the region. Its visibility was enhanced through effective advertising focusing on the new Powermatic 80 movement. Balmain had great exposure with additional shop-in-shops, especially in Saudi Arabia and the UAE. In September, an event at Avenues Mall in Kuwait with Dominique Rinderknecht, Miss Switzerland, enhanced brand awareness. The implementation of Certina's new corporate identity was finalized and its impact was felt across all markets, signaling a positive year, particularly in the UAE. Hamilton had another strong year, working closely with key markets to maximize the impact of its roles in important movies. Enhancing the brand's presence in the stores was a major target and several shop-in-shops were installed in the region. Calvin Klein watches + jewelry enjoyed great brand awareness and strong demand for its products. It once again expanded its shop-in-shop network and reinforced its visibility.

Swatch reinforced its position in the region thanks to steady focus on a larger distribution network. Regional training contributed to higher sales and a sense of belonging to the brand. Targeted marketing contributed to the good reception given to Pastry Chefs, Big Classic and SISTEM51 collections, the last of which was also supported with special pop-up stores. In December, a unique Swatch store opened in Dubai featuring "Ladder" furniture in an environment blending marketing and sales strategies. It is in Boxpark, where minimalistic pop-up architecture meets contemporary urban chic.



84



85



86



87



88



89



90



91

SWATCH GROUP SOUTH AFRICA

90 / 91

In a successful year, Swatch Group South Africa showed positive growth and continued to build market share with all brands strengthening their positions in their respective market segments.

Breguet ended an exceptional year by hosting the first ever event held in Johannesburg, cementing the brand positioning achieved during the course of the year. Blancpain experienced increased growth and established its strong position by concentrating on shop-in-shop displays as well as targeted media campaigns. Omega focused on various training programs and proudly announced the first Ambassador Training, which was held in Cape Town in July.

Longines enjoyed exceptional growth and gained great exposure by inviting top local retail partners to the Glasgow 2014 Commonwealth Games. The very first South African Rado Star Prize, combined with participation and sponsorship of the World Design Capital® held in Cape Town, gave Rado credibility and a strong association with design in South Africa.

Tissot continued to increase brand awareness and also organized a training program attended by 125 members of staff. The year was concluded with the opening of a stand-alone kiosk in Cape Town. Calvin Klein watches + jewelry placed its focus both on positioning itself in the fashion arena and on the Swiss Made environment, through strong advertising campaigns.

In November Swatch opened its largest store to date in the tourist area of Victoria & Alfred Waterfront, Cape Town.

Peterhof, Bahnhofstrasse, Zurich – Swiss market



GOVERNANCE

ENVIRONMENTAL
POLICY
SOCIAL POLICY
CORPORATE
GOVERNANCE



ENVIRONMENTAL POLICY

ENVIRONMENTAL AND SAFETY POLICY

Environmental protection and safety represent key principles for all sectors of Swatch Group. These principles are followed, promoted and implemented daily by every employee. Each takes great care to respect our environment and to pay the greatest respect to both the environment and safety considerations in general. These guiding principles are part of environmental, social and corporate governance values (ESG) that are of the highest value to everyone, as is also expressed in the various sections of this Annual Report.

As a matter of principle, resources are used efficiently and sparingly in order to ensure the ecological and sustainable production and commercialization of the products. Even at the very beginning of the planning and development phases of new products, only easily recyclable raw and auxiliary materials as well as ecological production methods are taken into consideration.

In particular, actions are implemented to reduce energy consumption, whether through production installations equipped with intelligent energy management systems or through the energy optimization and thermal insulation of facilities. The most recent technologies and thermal insulation were used for the construction of new sites, such as Universo in La Chaux-de-Fonds (NE), the ETA facilities in Boncourt (JU) and in Grenchen (SO), and for renovation projects, in order to improve their ecological and energy consumption, which once again resulted in great progress in this regard during the reporting period.

All the relevant values related to operational ecology are annually collected, consolidated and analyzed. The data are incorporated into the analysis of the results achieved and provide a benchmark for new objectives to be achieved.

PROGRESS ACHIEVED

The targeted measures once again focused on environmentally-relevant areas such as energy, water, air and waste management. As in previous years, the parameters observed in the various affiliated companies showed significant contrasts, thus reflecting the wide variety of activities covered by the Swatch Group companies. Overall, the development recorded during the year under review was very encouraging, taking into consideration the new increase in production in the watchmaking and jewelry sectors, as well as the production of movements and watchmaking components, in addition to the continued expansion of distribution networks.

Here are a few examples of the progress achieved:

CO₂ EMISSIONS RESULTING FROM ENERGY CONSUMPTION

Compared to the previous year, total consumption of fossil energies decreased by 7.0 million kWh, or 6.7%. This highly positive result was achieved thanks on one hand to a reduction in the con-

sumption of heating oil and natural gas and on the other, to an increase in the share of renewable energy sources, such as solar power and hydraulic energy.

In spring 2013, Swatch Group decided to have its entire production site participate in a program to reduce CO₂ emissions. Within this framework, a voluntary program of economic and ecological measures required to reduce energy consumption and the resulting CO₂ emissions was agreed upon with the Swiss Federal Office for the Environment (FOEN). The aim of this agreement is to further reduce energy consumption from 2013 to 2020.

In collaboration with the Swiss Economic Energy Agency (EnAW), energy audits were conducted in 2013 by internal specialists at each one of the sites concerned and new possibilities of reducing CO₂ emissions were identified. A catalogue of the most appropriate activities to be implemented to achieve the set objectives was thus developed. The measures defined have since been systematically implemented, enabling a considerable reduction in CO₂ emissions with a number of production sites consequently being exempt from CO₂ tax. The catalogue of measures is regularly reexamined and updated, meaning that a further significant contribution can still be made to climate protection.

ELECTRICAL CONSUMPTION BY FLOOR SPACE (KWH / M²)

Compared to the previous year, consumption of electricity by floor space unit increased by 4.5%. This increase in consumption can be explained by the tremendous increase in production, the integration of new production workshops and the continued expansion in the number of points of sale. The implementation of new machines and installations with improved energy consumption in several production units, as well as significant investments with regard to lighting, the renovation of the existing systems and the introduction of LED technologies, enabled a proportionately lesser increase in electrical consumption compared with the overall increase in activities.

ENERGY CONSUMPTION BY FLOOR SPACE (KWH / M²)

Measured in kWh per m², energy consumption by floor space using heating oil, natural gas and remote heating decreased by 11.5% during the reporting year, notwithstanding the increase in production volumes in all segments and the extension of the distribution network. This encouraging result was achieved thanks to ultra-modern heating technology incorporated into new buildings and the replacement of different air-conditioning and water-cooling systems, as well as the renovation of heating systems and the implementation of new heat recovery systems. These regular investments over the past decade have enabled energy consumption by floor space to be reduced by more than half.

WASTE MANAGEMENT

Due to the increase in production volumes, the amount of special waste (excluding watch batteries) increased by 27.6%, and the

share of recovered or recycled special waste increased by 8.7%. Following the significant increase in production, other industrial waste such as paper, cardboard, synthetic material and electronic components, increased by 11.5%, while the proportion of recycling of industrial waste rose during the same period to more than 19.7%.

BATTERY RECYCLING

During the reporting year, the quantity of batteries collected and delivered to registered companies specialized in recycling increased to more than 10.7 tons, excluding the elimination of expired batteries and the liquidation of end-of-series at Renata.

WATER MANAGEMENT

Considerable progress was once again made in this area too. Compared to the previous year, consumption of drinking water only increased by 1.6% despite the increase in production and the increase in staff numbers and work teams (consumption of drinking water per person), as well as the increase in the number of air-conditioning installations. On the other hand, consumption of non-potable water decreased by 1.6%. Special mention should be made of the reduction in waste water achieved by the installation of closed water circuits and the improved yield of wastewater treatment plants as well as the use of rainwater recovery systems and the use of this rainwater for cooling and sanitary systems.

EMISSIONS OF VOCs (VOLATILE ORGANIC COMPOUNDS)

The increase in production volumes during the reporting year, compared to the previous year, was responsible for the increase in the consumption of VOC products. This was due primarily to an increased use of acetone, alcohol and benzene as cleaning agents for produced components. This meant that VOC emissions increased, while 22.9% of the additional VOCs were recovered or recycled, notably due to the implementation of processes for recovering benzene and other volatile solvents. The increase in VOC emissions was also contained by further replacement of volatile substances with processes using aqueous solutions that do not contain solvents or less volatile substances.

RISK MANAGEMENT

Risks deemed to be decisive factors are constantly identified and covered within the framework of the Corporate Risk Management System. Appropriate measures are elaborated and implemented in order to eliminate potential incidents. A main focus is placed on Business Continuity Management. Experts pinpoint the important operational units and their interdependence, as well as the principal risks (fire, flooding, chemical substances, interruption of production), and identify the necessary measures to ensure business continuity. Preventive and emergency measures are key elements in Swatch Group's risk management, of which the policy of interdependence is an essential aspect. This implies, therefore, that wherever it is deemed useful, the company reduces its dependence with regard to its suppliers, distribution partners or financial service providers. The measures taken in this respect notably include maintaining sufficient inventory stock levels, developing and modernizing production capacities, diversifying supply sources, acquisitions and a high equity ratio.

The highest levels of attention are given to staff health and safety. Legal requirements in this regard are strictly adhered to and all the necessary resources are thus committed to achieving this objective.

Environmental, ethical and social criteria are also an integral part of the procurement policy of Swatch Group, which is con-



scious of its responsibilities with regard to the procurement of specific raw materials used in the industry, such as precious metals, diamonds and exotic leathers. In addition, the company has therefore freely decided to renounce the use of wood from threatened species of trees and to use only wood from sustainable plantations, in order to make an additional contribution to improving the ecological balance. Swatch Group also requests, to the extent possible, that its suppliers guarantee that precious metals delivered are sourced from regions with irreproachable ethics and exempt from armed conflict, and that they comply with all legal supply chain requirements. In the same way, the company ensures that the diamonds used for its products are sourced only from suppliers strictly complying with and following the certification system stemming from the Kimberley Process. Finally, with regard to the requirement for exotic leathers, the company is careful to use only materials from controlled breeders.

With respect to sustainable production methods and products, Swatch Group fully complies with the applicable regulations, notably those of the European Union, such as the directive regarding the limitation of the use of certain dangerous substances (RoHS), the regulation governing the registration, evaluation, authorization and restriction of chemical products (REACH) and the directive regarding the elimination of electrical and electronic equipment waste (DEEE).

Complementary information on energy and ecology is provided by Belenos on page 106 of this report, while Swatch Group Quality Management covers environmental protection and safety measures on page 107.

SOCIAL POLICY

One of the main factors in the sustainability and success of a company is the commitment and efficiency of its employees. Strong believers in this principle, Swatch Group and the various management boards of all its companies strive to ensure the development and fulfillment of their employees on a daily basis, and are committed to providing dynamic, motivational modern framework conditions for them.

JOBS

Regarding jobs, 2014 will be remembered as the year in which Swatch Group moved to another level, as the staff complement on December 31, 2014 exceeded 35000 employees, which represents the creation of 1500 jobs compared to the end of 2013. In addition, the staff complement outside of Switzerland represents 50% of the job total. This is the first time that this proportion has been reached.

This significant increase in the number of jobs created at the international level is due to the dynamism of Swatch Group's retail activity, with the opening of a large number of points of sale in most countries where the company has subsidiaries.

This parity between the number of jobs in Switzerland and abroad also demonstrates Swatch Group's openness to the world and its commitment to its multi-cultural dimension as well as an increasingly important foothold in markets considered to be significant to the development of watchmaking.

STAFF DEVELOPMENT

Representing an entire mosaic of technical and personal competencies practiced by each and every employee in their workplaces, human capital is unquestionably one of the factors essential to a company's success in the long term.

To maintain and strengthen this essential resource, all individuals must be offered the opportunity to mobilize and develop their knowledge. In order to achieve this, Swatch Group continued to make considerable investment in the acquisition and mastery of know-how in all key areas in 2014.

INITIAL PROFESSIONAL TRAINING

Swatch Group has always believed in the importance of dual training, which alternates between the acquisition of practical knowledge within a firm and theoretical courses given at school, convinced that this enables it to perpetuate technical know-how in the regions in which it operates for professions ranging from the most traditional crafts to the most avant-garde technology.

Passing the mark of 500 apprentices, in nearly 40 different apprenticeship courses, working in companies in Switzerland at the start of the new academic year in autumn 2014 is concrete proof of this belief and the result of long-term commitment. This was in fact recognized in November 2014, when the Hans Huber Foundation Grand Prix for Occupational Training was awarded to Swatch Group as "the most important training company in the watchmaking industry and which represents an example to follow!" Aside from the honor it bestows, this award confirms the soundness of the choices made with regard to professional training and the relevance of the apprenticeship programs introduced

several years ago and regularly expanded. The entire Hans Huber prize will be invested in favor of apprentices who will be offered the option of applying for unique language training abroad.

Swatch Group is also committed to being an ambassador for dual formation and once again put considerable effort into raising awareness among youth through different events, such as Swiss Skills in Bern, which welcomed 155000 visitors in five days. This very first national professional training competition-exhibition provided an occasion for a great many contacts to be made with potential future apprentices who were introduced to the professions for which training is provided within the framework of Swatch Group companies.

NICOLAS G. HAYEK WATCHMAKING SCHOOLS

In 2014, the six Nicolas G. Hayek Watchmaking Schools across the world again enjoyed increasing success. Consequently, training capacities were increased with the recruitment of trainers and the creation of new apprenticeship positions in order to respond to the enthusiasm they generate and meet the demand they create. These schools play an essential role for all Swatch Group brands around the world that need to have access to professionals able to support customers and take charge of products in all phases of sales, advice, expertise and after-sales service.

PROFESSIONAL DEVELOPMENT

In 2014, Swatch Group also pursued its activities in the area of continuous education for the employees in its companies, and particularly at most production sites, in order to encourage the acquisition of new competencies and the ability to adapt to technological developments, means of production and products. This particularly involves observation workshops, competency assessments and improvement plans tailored to employee development and the evolving needs of their organizations.

SOCIAL PARTNERSHIP AND WORKING CONDITIONS

Listening, respect and mutual trust are among the fundamental values upheld by Swatch Group. This concern leads to collaboration and ongoing contact with staff committees internally and social partners externally. This social dialogue is essential to working together smoothly, a goal that the company systematically sets for itself.

In terms of working conditions, questions related to mobility remain a key focus. Activities conducted over the past few years were thus strengthened in 2014 through encouraging car-pooling and organizing group trips as well as supporting public transport and exchange car parks.

Finally, questions related to ergonomics have always naturally been taken into consideration in the establishment of jobs in order to offer every employee the best possible environment for the development of their talents.



CORPORATE GOVERNANCE

1. Group structure and shareholders

1.1 Group structure

The Swatch Group is active worldwide and represented in all market and price segments in the watch sector with 20 brands and in the jewelry sector. In addition, it holds an outstanding industrial position with a high degree of verticalization in the Production sector as well as the strategically important sector of Electronic systems. In the Corporate sector, the operational units which provide services for the whole Group are centralized.

The Swatch Group has lean and efficient management structures at all levels. While the Board of Directors deals with the overall management, strategic and supervisory tasks, the operative executive duties are incumbent on the Executive Group Management Board, which is supported by the Extended Group Management Board.

An overview of the operational and of the distribution organizations is given on pages 4 and 5. The fully consolidated companies, of which none but The Swatch Group Ltd is listed on the Stock Exchange, are given on pages 201 to 204 with each company's name, domicile, share capital and the percentage of shares held.

The shares of The Swatch Group Ltd are listed on the SIX Swiss Exchange AG. The bearer shares are listed under the ISIN number CH0012255151 at the SMI, SPI as well as SLI indices. The registered shares are listed under the ISIN number CH0012255144 at the SPI, SPI Extra and SMIM indices.

ISIN:	CH0012255144	registered shares
	CH0012255151	bearer shares
Reuters:	UHRN.S	registered shares
	UHR.VX	bearer shares
Telekurs:	UHRN, 1	registered shares
	UHR, 1	bearer shares

Since February 2007 the shares of the Swatch Group are also listed on the BX Berne eXchange.

Further information concerning market capitalization and earnings per share is shown on page 217.

The corporation's registered office is located in Neuchâtel, Faubourg de l'Hôpital 3. The administrative headquarters are in Biel/Bienne, Seedorstadt 6.

1.2 Significant shareholders

As of 31 December 2014, the Hayek Pool, related parties, institutions and persons control 63 169 930 registered shares and 1650 bearer shares, totalling 40.8% (previous year 40.8%) of the votes.

The Hayek Pool comprises the following members:

Name/Company	Location	Beneficial owners
Community of heirs of N. G. Hayek represented by Marianne Hayek	Meisterschwanden	Community of heirs of N. G. Hayek
WAT Holding AG	Meisterschwanden	Community of heirs of N. G. Hayek
Ammann Group Holding AG	c/o Ernst & Young AG, Bern	Descendants U. Ammann-Schellenberg sen.
Swatch Group Pension Fund	Neuchâtel	—

The companies and institutions close to the Hayek Pool but which do not formally belong to the Hayek Pool are:

Name/Company	Location	Beneficial owners
Hayek Holding SA	Meisterschwanden	Community of heirs of N. G. Hayek
Community of heirs of N. G. Hayek and family members		Community of heirs of N. G. Hayek
Personalfürsorgestiftung der Hayek Engineering AG	Meisterschwanden	—
Families Ammann (pension funds, foundations and individuals, Madisa AG)	c/o Ernst & Young AG, Bern	Represented by Daniela Schneider
Fondation d'Ebauches SA et des maisons affiliées	Neuchâtel	—
Various employer-funded foundations ¹⁾	Various	—

¹⁾ Wohlfahrtsstiftung der Renata AG, ETA Wohlfahrtsstiftung, Fonds de prévoyance d'Universo, Fondation Technocorp, Fondation de prévoyance de The Swatch Group Les Boutiques SA and CP Caisse cadre

The community of heirs of N. G. Hayek controls directly, through related parties and institutions and in the context of the Pool 40.3% (previous year 40.4%) of the votes; third party Pool members are represented therein, they comprise 4.2% of the Swatch Group voting rights.

CORPORATE GOVERNANCE

Mrs Esther Grether's group controls 5.9% (previous year 7.1%) of the votes registered at 31 December 2014 in the share register. The reduction is due to a change in the group structure of Mrs Grether, which was notified to the SIX Swiss Exchange AG on 4 November 2014.

On 31 December 2014, no other individual shareholder or group of shareholders holding more than 5% is known to the Company.

1.3 Cross-shareholdings

The Swatch Group holds no cross-shareholdings.

2. Capital structure

2.1 Capital

On 31 December 2014, the capital structure of The Swatch Group Ltd was as follows:

124 045 000 Registered shares at CHF 0.45 par value	CHF	55 820 250.00
30 840 000 Bearer shares at CHF 2.25 par value	CHF	69 390 000.00
Total share capital as of 31.12.2014	CHF	125 210 250.00

2.2 Authorized and conditional capital

No authorized and conditional capital existed as of 31 December 2014.

2.3 Changes in capital

Over the past three years the share capital of The Swatch Group Ltd changed as follows:

Balance sheet date	Registered shares	Bearer shares	Share capital in CHF
31.12.2012	124 045 000 at CHF 0.45	30 840 000 at CHF 2.25	125 210 250.00
31.12.2013	124 045 000 at CHF 0.45	30 840 000 at CHF 2.25	125 210 250.00
31.12.2014	124 045 000 at CHF 0.45	30 840 000 at CHF 2.25	125 210 250.00

The detailed evolution of equity, reviewed by the auditors for the consolidated financial statements for the years 2013 and 2014, is published on page 167. For The Swatch Group Ltd, it is published for the year 2014 in note 11 on page 211. With regard to the previous years we refer to the annual reports 2011, 2012 and 2013.

2.4 Shares and participation

The shares of the Company listed in point 2.1 are fully paid in. Each share carries one vote. Both categories of shares confer equal entitlement to dividends according to their nominal value. No participation notes have been issued.

2.5 Benefit certificates

No benefit certificates exist.

2.6 Limitations on transferability and nominee registrations

The Articles of Association of the Swatch Group stipulate that the Board of Directors shall refuse the registration of new shares, if the new shareholder fails to give an express written declaration to the effect that he or she acquired the shares in his/her own name and for his/her own account. Furthermore, the Board of Directors refuses a registration if the purchaser, either alone or in conjunction with related persons, already holds 5% or more of the registered share capital (either directly or indirectly) at his disposal, or would exceed this threshold with the new acquisition (Art. 9 para. 3 of the Articles of Association). The Board of Directors may approve exceptions to this rule in special cases. No such exceptions were requested in the period under review.

Insofar as an individual or a legal entity was already entered in the share register before the reporting date of 31 May 1997 with 5% or more of the registered share capital, the Board of Directors must approve even though the percentage limits have been exceeded. The same exception applies for related persons (spouse, descendant, brother, sister), transfers due to inheritance or matrimonial property rights as well as certain transfers between legal entities or individuals subject to the exception (Art. 9 para. 6 and 7 of the Articles of Association).

Where a share purchaser presents an application for recognition as a shareholder of the company, he shall be regarded as a shareholder without voting rights until the company has recognized him as a shareholder with voting rights. If the company fails to refuse the purchaser's application for recognition within 20 days, he shall be acknowledged as a shareholder with voting rights. A shareholder who has no voting right may exercise neither the voting right nor the other associated rights.

2.7 Convertible bonds

The Swatch Group currently has no outstanding convertible bonds.

CORPORATE GOVERNANCE

2.8 Options

In 1986, a block of shares was reserved in favor of a management stock option plan in connection with the takeover of control of the Swatch Group by the Hayek Pool. On 31 December 2014, the content of this portfolio amounted to 1 154 463 registered shares; this corresponds to 0.41% of the total share capital (previous year 1 396 771 registered shares, 0.5% of the total share capital). In 2014, 242 308 registered shares (or 0.09% of the total share capital per 31.12.2014) were consequently sold at a preferential price of CHF 4.– per registered share in accordance with the following details:

Year of issue	Number of registered shares	Number of beneficiaries	Year of subscription/payup
2012	80 091	218	2014
2013	81 855	224	2014
2014	80 362	216	2014
Total	242 308		

In addition, the Group gave participating managers the following options to subscribe in future to further registered shares at the following preferential prices:

Year of issue	Number of registered shares	Number of beneficiaries	Year of subscription/payup
2013	80 365	216	2015
2014	80 112	214	2015
2014	80 331	214	2016
Total	240 808		

The allocation results from personnel reviews and proposals for employees who stood out through special achievements in the past year and have performed with above-average commitment. The allocation is then approved by the Board of Directors / the Compensation Committee. It allows a first purchase of a third of the promised number of registered shares in the current year, which can be paid up and claimed immediately, and another third in one and two years respectively. With the exception of Mrs Nayla Hayek and Mr G. N. Hayek no members of the Board of Directors received options or shares under this plan.

CORPORATE GOVERNANCE

3. Board of Directors

3.1 Members of the Board of Directors (incl. 3.2 and 3.3)

The Board of Directors on 31 December 2014 is composed as follows:

Nayla Hayek, Swiss citizen, Dr h.c. European University Montreux, Montreux, is Chairwoman of the Board of Directors of the Swatch Group since June 30, 2010. Mrs Nayla Hayek has been on the Board of Directors of the Swatch Group since 1995; from May 12, 2010 she was Vice-Chairwoman of the Board of Directors. As a member of the World Arabian Horse Organization (WAHO), and as international Arabian horse judge, Mrs Hayek's top-level contacts contribute to many of the business and promotional activities of the Swatch Group and she is responsible for the local organization in Dubai (Swatch Group Middle East) on site. In the middle of 2007, her advisory mandate was converted into an employment agreement. Following the acquisition of Harry Winston (26.03.2013), Mrs Hayek was appointed president and CEO of this new business entity. As Board member of the Hayek Group, she is responsible for Hayek Engineering AG, Hayek Immobilien AG and Hayek France SA. Mrs Hayek is Chairwoman of the Board of Directors of the Rivoli Group, Dubai and represents the interests of Swatch Group. She is also a member of the Board of Directors of Belenos Clean Power Holding Ltd. She holds no official function or political office.

Ernst Tanner, Swiss citizen, has been on the Board of Directors of the Swatch Group since 1995. He has been Vice-Chairman of the Board of Directors since June 29, 2011. Mr Tanner is Chairman and Delegate of the Board of the Lindt & Sprüngli Group. Before his activity with Lindt & Sprüngli, he was for over 25 years in leading management positions with the Johnson & Johnson Group in Europe and the USA, ending up as Company Group Chairman Europe. In addition, he is a member of the Board of Directors of the German Krombacher Brauerei GmbH & Co. KG. Otherwise, he exercises no other executive or advisory functions and holds no official function or political office.

Nick Hayek, Swiss citizen, pursued two years' study at the University of St. Gallen (HSG), then attended the Film Academy CLCF in Paris. President of the Executive Group Management Board since 2003 and member of the Board of Directors since 2010. Mr Hayek has worked with the Swatch Group since 1994, firstly as Swatch Ltd Marketing Manager, then as Swatch Ltd President and finally as Delegate of the Board of Directors of Swatch Ltd. In the mid-eighties, he founded his own production company, Sesame Films in Paris, and worked in Switzerland and abroad. His involvement in a number of film productions (e. g. a series of documentaries for Swiss Television), then the production of a number of short films (e. g. 1st prize at the Thessaloniki Film Festival, an official contribution to the Cannes Film Festival, etc.) and his activity as producer and manager of two feature films, «Das Land von Wilhelm Tell» and «Family Express» with Peter Fonda (a film that earned him the prize for the best Swiss comedy at the Charlie Chaplin Comedy Film Festival in Vevey) resulted in his being called upon to advise on various Swatch projects in the early '90s and to assume responsibility for several Swatch exhibitions (such as that of Lingotto in Turin). Mr Hayek is a member of the Board of Directors of the CSEM (Centre suisse d'électronique et de microtechnique) and of Belenos Clean Power Holding Ltd.

Prof. Dr h. c. Claude Nicollier, Swiss citizen, graduated in Physics and Astrophysics from the Universities of Lausanne and Geneva. Mr Nicollier has been a member of the Board of Directors since 2005. Mr Nicollier resigned from his activities as astronaut at the European Space Agency ESA in March 2007. As an astronaut he was particularly active in the space missions Atlantis 1992, Endeavour 1993, Columbia 1996 and Discovery 1999. The aim of the Endeavour and Discovery missions was the execution of reparation works on the Hubble Space Telescope which were a complete success. The Universities of Geneva and Basel and the École Polytechnique Fédérale de Lausanne, where Mr Nicollier teaches as a titular professor at the school of engineering, have conferred honorary doctorates on him. Mr Nicollier is involved in the «Solar Impulse»-Project and is responsible for the test flights. He is member of the Board of Directors of Belenos Clean Power Holding Ltd. Mr Nicollier does not exercise any operative functions at Swatch Group, does not have any business relationship with Swatch Group and holds no political office.

Dr Jean-Pierre Roth, Swiss citizen, Dr oec. Graduate Institute (HEI) Geneva, has been a member of the Board of Directors since 2010. Following postgraduate studies at the Massachusetts Institute of Technology in the USA, Mr Roth taught at the University of Geneva and at the Graduate Institute (HEI). In 2009 the University of Neuchâtel conferred him a honorary doctorate in economics. Jean-Pierre Roth joined the Swiss National Bank in 1979 where he was active in various areas in Zürich and Bern. On May 1, 1996 he was appointed Vicepresident of the board and director of the II. Department (equity market, bank notes, business relationships with the federal government, administration of the gold reserves) in Bern by the Swiss federal council. On January 1, 2001 he was elected President of the board and chief of the 1. Department (political economics, international affairs, law and services) in Zürich. Jean-Pierre Roth was Swiss governor of the International Monetary Fund (IMF) in Washington. From March 1, 2006 until end of February 2009 he was Chairman of the Board of Directors of the Bank of International Settlements (BIS) in Basel. From end of March 2007 until end of 2009 he represented Switzerland in the Financial Stability Forum, an international committee consisting of representatives from the ministries of finance, central banks and regulatory authorities to tighten the collaboration on surveillance of the international financial system. At the end of 2009, Mr Roth resigned as President of the Swiss National Bank. Mr Jean-Pierre Roth was elected as member of the Board of Swiss Re and of Nestlé Ltd in 2010. In 2014, he was elected as member of the Board of MKS (Switzerland). Since July 1, 2010, Mr Roth is President of the Banque Cantonale de Genève (BCGE).

CORPORATE GOVERNANCE

3.4 Elections and terms of office

The members of the Board of Directors are elected at the Ordinary General Meeting of the shareholders for a term of one year. The period between two Ordinary General Meetings is regarded as one year. The members of the Board shall be eligible for re-election at any time. There is no limit on the age and/or term of office. According to Article 18 of the Swatch Group Articles of Association the votes and elections take place openly, except where the Chairman orders a written election or vote. One or more shareholders, who together dispose of not less than 10% of the represented votes, may require written votes or elections.

First-time election and remaining term of office of the members of the Board of Directors:

	First-time election	Term of office
Nayla Hayek	1995	Up to 2015
Georges Nicolas Hayek	2010	Up to 2015
Prof. Dr. h.c. Claude Nicollier	2005	Up to 2015
Dr. Jean-Pierre Roth	2010	Up to 2015
Ernst Tanner	1995	Up to 2015

On the occasion of the General Meeting 2013 the members of the board of directors were re-elected for another term of three years. Since, the Ordinance Against Excessive Compensation in Listed Stock Corporations (Compensation Ordinance) has entered into force on 1.1.2014, pursuant to which directors may only be elected for a term of office of one year. Accordingly, the members of the board of directors (and the Chairwoman) were again proposed for re-election and elected at the General Meeting 2014 (each individually and for a one year term of office).

Mr Jean-Pierre Roth has been designated as the representative of the bearer shareholders and Mrs Nayla Hayek as representative of the registered shareholders.

Changes in the Board of Directors

At the General Meeting 2014, Mrs Esther Grether tendered her resignation, respectively declined to serve a further term, due to health reasons. As this did not cause the number of directors to fall below the lower limit as determined by the Swatch Group Articles of Association, the board of directors dispensed with a proposal to the General Meeting for a replacement for the time being.

3.5 Internal organizational structure of the Board of Directors

At the General Meeting 2014, the Chairwoman of the Board of Directors (Mrs Nayla Hayek) was for the first time elected by the shareholders, in accordance with the Compensation Ordinance (for the period until the next General Meeting). For the rest, the Board of Directors is self-constituting. It has appointed a Vice-Chairman (Mr Ernst Tanner) from its midst. The office of Secretary to the Board of Directors is carried out by Mrs Meyer-Kluge. The Secretary to the Board of Directors is not a member of the Board. The term of office of the Chairman, the Vice-Chairman and the Secretary is, in each case, one year. They are all re-eligible for a further term of office. If an officer is substituted, the successor completes the remainder of the term of the predecessor. The Board of Directors has an Audit Committee and a Compensation Committee at its disposal. These committees, which sit separately (normally immediately following an ordinary meeting), because of the relatively small number of company directors, comprise all the members of the Board of Directors. The Audit Committee is chaired by Mrs Nayla Hayek. Until the General Meeting 2014, the Compensation Committee was also headed by Mrs Nayla Hayek. After the election of the members of the Compensation Committee by the General Meeting, which took place for the first time, Mr Ernst Tanner was entrusted with the Chair of the Compensation Committee by the Board of Directors.

The Audit Committee is mainly responsible for the supervision of the financial reporting and for the evaluation of the internal and external audit. The Audit Committee has particularly fulfilled the following functions:

- Review of the Audit reports,
- Reinforcement of points which the auditing firm raised,
- Determination of the audit focal points,
- Discussions of the efficiency of the internal control system including risk management,
- Appraisal of the performance, remuneration and independence of the external auditors,
- Dealing with special questions of the financial statements (for further details see also point 8.4).

The Compensation Committee concerns itself with the compensation policy of the company. It supports the Board of Directors in determining the compensation systems and the principles of compensation as well as the preparation of proposals to the General Meeting with regard to the approval of compensation. The Compensation Committee can submit proposals and recommendations to the Board of Directors in all compensation matters.

With the entry into force of the revised Swatch Group Articles of Association, the Compensation Committee will deal with all questions in the field of compensation and propose solutions to the attention of the Board of Directors. The Board of Directors is the decision-making body. It submits the required resolutions to the General Meeting for approval.

Further details can be found in the separate Compensation Report which is made for the first time covering the business year 2014.

CORPORATE GOVERNANCE

The Board of Directors does not have a Nomination Committee at its disposal. The tasks of the Nomination Committee (determination of the criteria for the selection of candidates for election as members of the Board of Directors, selection procedure, etc.) are carried out directly by the Board of Directors, in view of the small number of members.

In the year under review, the Board of Directors met five times. The meetings lasted approximately three to four hours. The Compensation Committee and the Audit Committee both met twice.

The members of the Executive Group Management Board regularly attend the ordinary meetings of the Board of Directors (second part). Beside the President (CEO) of the Executive Group Management Board, the Chief Financial Officer (CFO) and the Chief Legal Officer (CLO) and, if necessary, any other members of the Executive Group Management Board, attend the meetings of the Audit Committee. The Chief Legal Officer (CLO) participates in the meetings of the Compensation Committee as he attends to the personnel issues of the members of the Executive Group Management Board and Extended Group Management Board. Where there are discussion points concerning a person present, such person withdraws from the meeting.

3.6 Definition of areas of responsibility

The Board of Directors is the highest executive body responsible for the overall administration of the Group. It adopts strategic decisions and defines the means necessary for attaining the long-term goals. It determines, inter alia, the participation and appointment of the members of the Executive Group Management Board, the Extended Group Management Board and the heads of the main Group companies. Moreover, the Board of Directors approves the annual budget of the Group and its affiliated companies and decides on investments over CHF 3 million, as well as on each commercial operation of the affiliated companies which exceeds CHF 10 million. The Board of Directors prepares the General Meeting and drafts the annual report as well as the half-year report.

The Board of Directors has delegated the current operative business to the Executive Group Management Board, the Extended Group Management Board and to the Holding Company Management.

The Executive Group Management Board is responsible for implementing Group strategies. It sets strategies and objectives for the Group companies and supervises their management.

The Extended Group Management Board supports and advises the Executive Group Management Board in its operative tasks. It makes suggestions for the development of the Group strategy.

The individual members of the Executive and Extended Group Management Boards manage their allocated areas within the framework of the Group policy and in accordance with guidelines set by the Executive Group Management Board.

The Holding Company Management is responsible for the current operative business of the Holding Company.

3.7 Information and control instruments

Each member of the Board of Directors can request to receive information on all issues concerning the Company and on important issues concerning the Group companies.

The members of the Executive Group Management Board report at the Board of Directors meetings on current business and important business issues. In particular, the members of the Board of Directors regularly receive detailed information regarding turnover and results trends for the Group and Group Divisions. Furthermore, important business issues, new products and the Group's financial status are reported in detail. Moreover, extraordinary occurrences are immediately brought to the attention of the Board.

Outside meetings, each member of the Board of Directors may seek information on the general progress of business from authorized management (after informing the Chairwoman). With due authorization of the Chairwoman, they may also demand direct information on individual business transactions. Should the Chairwoman reject an application for information, a hearing or an inspection (which has never occurred so far), the entire Board of Directors shall decide at the request of the applicant.

The Chairwoman of the Board of Directors has an Audit-Team available, which she may deploy in specific cases.

4. Group Management (Executive Group Management Board/Extended Group Management Board)

At December 31st, 2014

4.1.a Members of the Executive Group Management Board (incl. 4.2)

Nick Hayek, Swiss citizen, pursued two years' study at the University of St. Gallen (HSG), then attended the Film Academy CLCF in Paris. President of the Executive Group Management Board since 2003 and member of the Board of Directors since 2010, Mr Hayek has worked with the Swatch Group since 1994, firstly as Swatch Ltd Marketing Manager, then as Swatch Ltd President and finally as Delegate of the Board of Directors of Swatch Ltd. In the mid-eighties, he founded his own production company, Sesame Films in Paris, and worked in Switzerland and abroad. His involvement in a number of film productions (e. g. a series of documentaries for Swiss Television), then the production of a number of short films (e. g. 1st prize at the Thessaloniki Film Festival, an official contribution to the Cannes Film Festival, etc.) and his activity as producer and manager of two feature films, «Das Land von Wilhelm Tell» and «Family Express» with Peter Fonda (a film that earned him the prize for the best Swiss comedy at the Charlie Chaplin Comedy Film Festival in Vevey) resulted in his being called upon to advise on various Swatch projects in the early '90s and to assume responsibility for several Swatch exhibitions (such as that of Lingotto in Turin). Mr Hayek is a member of the Board of Directors of the CSEM (Centre suisse d'électronique et de microtechnique) and of Belenos Clean Power Holding Ltd.

CORPORATE GOVERNANCE

Florence Ollivier-Lamarque, French citizen, is a lawyer and has been a member of the Extended Group Management Board since 1992 and of the Executive Group Management Board since 2005. She is President of Swatch Group France, Swatch Group France Les Boutiques, responsible for Swatch Group Italy, Swatch Group Spain, Swatch Group Belgium and Swatch Group Netherlands as well as for the watch brand Flik Flak. She has been with the Group since 1988 when it took over the Société Inthor, Paris, which distributed some of the Group's watches in France. At that time, she worked as Swatch and Tissot Brand Manager. In 1990, she took over the management of Swatch Group France and in 2002 the management of Swatch Group France Les Boutiques. She is member of Board of the Colbert Committee, Paris.

Pierre-André Bühler, Swiss citizen, technical education, member of the Extended Group Management Board since 2008 and of the Executive Group Management Board since 2013, responsible for ETA. Mr Bühler started his career within the Group in 1977 as manager of the industrialisation division at Michel SA in Grenchen. Later Mr Bühler held executive functions at ETA (Technical manager of the division Michel) and at Nivarox (Production manager). Before taking over the general management of ETA, Mr Bühler worked as managing director of Nivarox-Far (Le Locle). He represents the Swatch Group on the Executive Board of the Federation of the Swiss Watch Industry FH and is a member of the Board of Directors of CSEM.

Dr Mougahed Darwish, Swiss citizen, holds a doctorate in Physics from the ETHL. He has been a member of the Extended Group Management Board since 1994 and of the Executive Group Management Board since 2005, responsible for EM Microelectronic, Micro Crystal, Renata and Oscilloquartz. Mr Darwish has been with the Group since 1979, starting as Project Manager for the Xicor-Ébauches joint venture. Previously, he had been active in research and development for the Centre électronique horloger (CEH, today Centre Suisse de l'électronique et de microtechnique SA, CSEM). From 1985 to 2007 he managed EM Microelectronic as CEO. Mr Darwish represents the Group on the Board of Directors and the Science Council of the CSEM as well as on the Board of FLRH; he is a member of the Swiss Academy of Technical Science. Since 2008, Mr Darwish actively accompanies the project Belenos Clean Power; since July 2010 he is a delegate of the Board of Directors of Belenos Clean Power Holding AG.

Marc Alexander Hayek, Swiss citizen, Dr h.c. European University Montreux, Montreux, holds a bachelor degree in Economics and has undergone training in Marketing and Economics. He became a member of the Extended Group Management Board in 2002 and of the Executive Group Management Board in 2005 with responsibility for Blancpain, the Caribbean, Central and South America, François Golay and Deutsche Zifferblatt Manufaktur and furthermore, since July 2010 for Breguet and Jaquet Droz. He joined Blancpain as Marketing Manager in 2001. Mr Hayek had previously worked as an independent entrepreneur (Restaurant Colors, Zurich) and had been employed by Swatch in the PR area and by Certina in marketing.

Dr Thierry Kenel, Swiss citizen, holds a doctorate in Economics, a degree in Mechanical Engineering and a postgraduate degree in Management of Technology. As a Member of the Extended Group Management Board since 2009 and of the Executive Group Management Board since 10.02.2012, he is responsible for Corporate Finance, Reporting and Investor Relations. Mr Kenel has been with the Swatch Group since 2003, first as Group Controller in the business segment Electronic Systems and subsequently as head of Finance, IT and Administration at Montres Breguet SA. Prior to joining the Swatch Group, Mr Kenel was a lecturer and researcher in the field of economics at the University of Lausanne; earlier, he was a member of the Board of Directors and the management of the Flumroc-Spoerry group of companies. Mr Kenel represents the Swatch Group in the Board of the Convention Patronale and in the Federation of the Swiss Watch Industry FH, where he presides over the Economic Commission. Mr Kenel continues to be a private lecturer of Finance and Financial Reporting at the University of Lausanne (HEC) as well as at the Swiss Institute of Certified Accountants and Tax Consultants. He is also a member of the Liaison Committee University-Industry at the University of Lausanne (HEC).

Dr Hanspeter Rentsch, Swiss citizen, holds a doctorate in Law and a degree in Economics (from HSG St. Gallen and Bern University). As member of the Extended Group Management Board since 1991 and of the Executive Group Management Board since 1995, he is responsible for legal affairs, licenses, strategic projects and patent matters (ICB), as well as for Swatch Group Greece and Swatch Group Poland. He joined the legal department of ASUAG in 1978. From 1980, he headed the legal and trademark department of the General Watch Co. Ltd and, after the merger, became General Counsel to the new group. He subsequently assumed additional functions in the areas of licenses, real estate and as Human Resources Responsible. Before joining the Swatch Group, he had been active as scientific assistant (Prof Dr W. R. Schlupe, Economic, Commercial and Competition Law chair) at Zurich University. He represents the Swatch Group on the Executive Committee of Economiesuisse, on the Executive Board of the Swiss Employers Association, on the Executive Board of the Swiss section of the International Chamber of Commerce (ICC), and on the Executive Board of the Federation of the Swiss Watch Industry FH. Since 20.09.2012 he performs the role of a Vice President of the Executive Board of the FH.

François Thiébaud, French citizen, studied at the ICG Institut Contrôle de Gestion, Paris and Law at the University of Besançon, and he has been a member of the Extended Group Management Board since 1998 and of the Executive Group Management Board since 2006, with responsibility for Tissot, Mido, Certina as well as Swatch Group Brazil and the Swiss market. He joined the Swatch Group in 1996 as Manager of Tissot. Previously, he had been active as Delegate of the Board of Directors of Juvenia and Manager of Breitling. He represents the Group in the AMS Association des fournisseurs d'horlogerie, marché suisse (Vice-Chairman), he is member of the Baselworld Consulting Committee and President of the Baselworld Swiss Exhibitors Committee.

CORPORATE GOVERNANCE

4.1.b Members of the Extended Group Management Board (incl. 4.2)

Raynald Aeschlimann, Swiss citizen, graduated with a degree in economics and an MBA from the University of St. Gallen (HSG). He was appointed to the Swatch Group's Extended Group Management Board in 2013. Mr. Aeschlimann has been Vice President and International Director of Sales, Retail and Distribution at Omega SA since 2001. He joined Omega in 1996 as Sales and Marketing Project Manager. He was also Brand Manager of Omega and Blancpain Spain in 2000 and has been the Group Coordinator for the Swatch Group's Indian subsidiary since 2010. Mr. Aeschlimann is on the Executive Board of the Federation of the Swiss Watch Industry FH. He had previously worked at Longines and Complemta AG in St. Gallen from 1992 to 1996.

Matthias Breschan, Austrian citizen, graduated from the Vienna School of Economics, has been a member of the Extended Group Management Board since 2005 and is responsible for Rado, Hamilton, for Swatch Group Mexico and Swatch Group Austria. Mr Breschan manages Rado since January 1, 2011. Before he managed Hamilton for seven years and worked as Area Sales Manager for three years at Swatch Telecom. Between his activity for Hamilton and Swatch Telecom he was Managing Director of Aldi in France (Aldi Marché Est). Before joining Swatch Group Mr Breschan worked for Texas Instruments and Alcatel Mobile Phones in the product marketing, international marketing and sales areas.

Jean-Claude Eggen, Swiss citizen, holds an engineering degree from the University of Applied Sciences (HES) in Biel/Bienne. He completed additional studies in business economics and automation and also obtained an Executive MBA. A member of the Extended Group Management Board since 2013, Mr. Eggen began his career at the Swatch Group in 1992 as director of SMH Engineering SA in Grenchen. He subsequently directed the MIM (Metal Injection Molding) activities for the production of steel cases at ETA Manufacture Horlogère Suisse SA. Prior to taking up a position as Vice President Swatch & Quartzline at ETA, Mr. Eggen also worked as Director of Operations for Phonak Communications SA, where he was responsible, inter alia, for organizing production in Vietnam.

Yann Gamard, French citizen, holds an MBA from Lausanne and has been a member of the Extended Group Management Board since 1998, responsible for Swatch Group Germany and Swatch Group Nordic (Denmark, Finland, Sweden, Norway). Mr Gamard is also responsible for the distribution logistic in Europe, as well as being responsible for Glashütte Original. He joined the Swatch Group in 1995 (Finance Department, Swatch AG). He subsequently assumed responsibility for the telecom business of the Swatch Group and was thereafter appointed as Country Manager for the USA. Before joining the Group, Mr Gamard held various posts with Procter & Gamble and Cartier.

Hans-Rudolf Gottier, Swiss citizen, holds an electrical engineering degree from the University of Applied Sciences (HES) in Biel/Bienne and is a member of the Swatch Group's Extended Management Board since 2013, where he is responsible for the segment Electronic Systems. Mr Gottier began his career in Swatch Group in 1980 as head engineer of the quartz production. Since 1990, he is the CEO of Micro Crystal Ltd. During this period, Micro Crystal was developed from being an internal quartz supplier for the watch business to being a worldwide quartz supplier. Over the recent years, Mr Gottier has led various companies within Swatch Group Electronic Systems and completed their restructuring. Prior to joining Swatch Group, Mr Gottier worked in South America where he was responsible for the technical implementation in connection with the importation of large machinery and installations.

Walter von Känel, Swiss citizen, with a commercial training, has been member of the Extended Group Management Board since 1991, with responsibility for Longines. He entered Longines in 1969 and became its President in 1988. Before joining Swatch Group Mr von Känel worked for a watch-dial factory and with the Federal Customs Administration. Mr von Känel is a member of the «Conseil du Jura Bernois».

Thomas Meier, German citizen, is a graduate engineer FH from the University of Applied Sciences Karlsruhe (Micromechanics and Microelectronics), with additional training in Business Administration at the University of Munich and an apprenticeship as watchmaker. He has been a member of the Extended Group Management Board since 2005. Mr Meier began his activities for Swatch Group in 1994 as project manager at Mido. Later he became project manager for Swatch Access. After a break he returned to Swatch Group in 1999 as project manager and later as production manager a.i. of Breguet. From 2004 until 2008 he was responsible for ETA and subsequently a member of the management of Frédéric Piguet. Since 2010, Mr Meier is responsible for the manufacture of the Breguet watch cases. Before joining Swatch Group, Mr Meier worked as development engineer for Jungheins in Germany.

Calogero Polizzi, Italian citizen, holds a diploma in information technology from the Industrial Technical Institute L. Cobiainchi in Verbania, Italy and is a member of the management of The Swatch Group Services Ltd. He was appointed to the Swatch Group's Extended Group Management Board in 2013. He has been responsible for the IT systems at Swatch Group since his appointment as CIO (Chief Information Officer) in 2005. Previously he worked as IT Manager in the Italian subsidiary of Swatch Group and as Head of IT at The Swatch Group Distribution LTD. Between his activities for Swatch Group Italy and Swatch Group Distribution he was Chief Information Officer at Tod's S.p.A. Before joining Swatch Group, Mr Polizzi worked at Whirlpool where he was engaged in various information technology positions at the international level.

CORPORATE GOVERNANCE

Kevin Rollenhagen, American citizen, graduated in Economics (BA) at the Michigan State University, has been a member of the Extended Group Management Board since 2005 and is responsible for Swatch Group China and Swatch Group Taiwan, Swatch Group Australia and Country Manager of Swatch Group Hong Kong (he represented these countries from 2000 onwards in the Extended Group Management). Mr Rollenhagen joined Swatch Group in 1989. He started his career as trainee at Tissot and became Regional Sales Manager for Tissot and Omega. Since 1994 he has been active in Hong Kong and China (first as Brand Manager Omega). Before joining Swatch Group Mr Rollenhagen worked with Caterpillar in sales. Mr Rollenhagen represents Swatch Group in the Hong Kong Watch Importers Association where he acts as Treasurer.

Dr Peter Steiger, Swiss citizen, who has a doctorate in Public Economics, has been a member of the Extended Group Management Board since 2002, with responsibility for The Swatch Group Corporate Controlling and Logistics, Swatch Group Malaysia, Swatch Group Singapore, Swatch Group Indonesia, Swatch Group Thailand and Swatch Group South Africa. He started his career with the Group in 1989 as Head of Finance and Administration with PC Quartz. Later, Mr Steiger held leading finance and logistics posts with various Group companies (among others Swatch and Longines). Before joining the Swatch Group, he had worked with international groups in Switzerland and abroad (Shell, Philips).

Stephen Urquhart, Swiss and British citizen, who studied Industrial Management at the University of Neuchâtel, has been a member of the Extended Group Management Board since 2000 and is President of Omega. Mr Urquhart began his career at Omega in 1968. From 1974 to 1997 he pursued his career with Audemars Piguet, where he became Joint Chairman and Delegate of the Board of Directors from 1989 onwards. Mr Urquhart returned to the Swatch Group in 1997 as President of Blancpain.

Employment Contracts

The contracts of employment with the members of the Executive and the Extended Group Management Board are entered into for an indefinite period of time and can be terminated by both parties with a six month notice period. In case of a cancellation no termination payment will be due. No entry bonus is paid by Swatch Group when entering new contracts (Golden Hellos).

In case of retirement there are no other entitlements to any compensation.

CORPORATE GOVERNANCE

4.1.c Changes in the Executive Group Management Board resp. Extended Group Management Board

During the year under review, there were no changes in the composition of the Executive Group Management Board and the Extended Group Management Board.

4.4 Management Contracts

Within the framework of a global contract, Hayek Engineering AG, Zurich, placed its management personnel in particular at the disposal of the operational activities of Lascor S.p.A., as well as in the areas of real estate and logistics.

Country Panel

At the beginning of 2014, a Country Panel was constituted with the task of supporting the Executive Group Management Board, in particular in the fields of distribution and international business development.

The Country Panel meets at least twice per business year. The meetings are chaired by the president of the Executive Group Management Board.

The function of the Country Panel is purely advisory. It is made up of the Country Managers of 11 important country organisations. In addition, there are 5 further members who are appointed by the Executive Group Management Board from among the presidents of the further country organisations (rotation principle).

At the end of 2014, the Country Panel consisted of the following persons:

G. Nick Hayek, Helmut Saller, Hazem Sbayteh, André Hernandez, Susan Chen, Roland von Keith, Partha Dattagupta, Laura Burdese, Christophe Savioz, Gaël Vallade, Stefan Peter, David Ponzo, Gonzalo de Cevallos, Frédéric Nardin, Frank Furlan, Julia Choi and Jose de Cardoso.

5. Compensation, shareholdings and loans

5.1 Compensation

On January 1, 2014, the Compensation Ordinance entered into force, requiring material alterations and adaptations as regards the compensation of the members of the Board of Directors and the Executive Group Management Board.

Thus, for the first time, a separate Compensation Report needs to be made for the business year 2014. The Compensation Report sets out the material elements of the compensation principles, of the tasks and competences in the field of compensation, of the composition and function of the Compensation Committee and of the various compensation elements, etc.

The separate Compensation Report also covers the loans and share programs and is thus referred to here.

At the General Meeting 2015, a revision of the Swatch Group Articles of Association will be proposed to the shareholders, accommodating the requirements of the Compensation Ordinance and implementing specific solutions of the company.

As part of the revision of the Swatch Group Articles of Association, the Board of Directors proposes to the General Meeting that the total compensation of the members of the Board of Directors and the Group Management be decided as follows:

- Resolution concerning the fixed compensation of the members of the Board of Directors for the period until the next Ordinary General Meeting,
- Resolution concerning the fixed compensation of the members of the Group Management (KL/EKL) for the current business year,
- Resolution concerning the variable compensation of the executive members of the Board of Directors for the completed business year,
- Resolution concerning the variable compensation for members of the Group Management (KL/EKL) for the completed business year.

5.2 Participation programs

The aims of the management stock option plan of the Swatch Group are to honour performances of the main Management members, strengthen the motivation and the sense of responsibility in the Group, further the loyalty to the firm as well as the stability of the managing employees and promote a favorable wealth increase. The allocation of shares results from an individual performance report. The voting rights of the shares in possession of the plan will not be exercised.

The share program is described in the Compensation Report.

An overview of the shares and options owned by the members of the Board of Directors, Executive Group Management Board and Extended Group Management Board and persons being closely related to them at 31 December 2014 may be consulted on page 214.

5.3 Loans

Loans to members of corporate bodies are considered in the Compensation Report.

CORPORATE GOVERNANCE

6. Shareholders' participation

6.1 Voting rights and representation restrictions

For the exercise of voting rights, no shareholder may combine, either directly or indirectly, more than 5% of the total shareholders' equity in respect of his own shares and those represented by him. This limitation does not apply to the shares which are excluded from the registration prohibition (point 2.6 above). Nor does this restriction apply to the exercise of voting rights by independent voting-right representatives.

Furthermore, pursuant to Art. 16(4) of the Swatch Group Articles of Association, the Board of Directors is entitled to make exceptions to the limitations in special cases. No exceptions were requested or granted during the business year. A change of the representation restrictions is only possible through a change of the provisions of the Articles of Association. For such change a decision of the General Meeting with a relative majority is required.

Shareholders may arrange to be represented at the General Meeting only by other shareholders who duly hold a written power of attorney. Registered shareholders may only be represented by other registered shareholders.

6.2 Statutory quorums

In addition to the special quorum regulations provided in Art. 704 CO, the Articles of Association also apply the same quorum regulation (two-thirds of the votes represented and an absolute majority of the par values of shares) for dismissing members of the Board of Directors.

6.3 Convocation of the General Meeting of Shareholders

The General Meeting is convened pursuant to Articles 13 and 14 of the Swatch Group Articles of Association. Shareholders who together own at least 10% of the share capital can, at any time, request in writing the convening of an extraordinary general meeting. Such an extraordinary general meeting shall be held within 40 days of the date of receipt of such a request.

6.4 Agenda

Shareholders who represent shares with a par value of one million Swiss francs may submit a written request for a meeting to be held to discuss a particular subject; the motions tabled shall likewise be indicated (see Article 13.2 of the Swatch Group Articles of Association in conjunction with Art. 699 and 700 OR).

6.5 Entries in the share register

The share register is closed for entries 20 days before each General Meeting.

7. Changes of control and defence measures

7.1 Duty to make an offer

Art. 10 of the Articles of Association provides that a shareholder who acquires shares either directly or indirectly or in agreement with third parties and by so doing exceeds the limit of 49% of voting rights, including the shares that he already possesses, regardless of whether those rights can or cannot be exercised, shall be required to make an offer to purchase all the listed shareholding papers of the Company (Art. 32 BEHG).

7.2 Clauses on changes of control

There are no agreements with members of the Board of Directors, the Executive Group Management Board or other managerial staff for the case of a change in the shareholder structure.

CORPORATE GOVERNANCE

8. Auditors

8.1 Duration of the mandate and term of office of the lead auditor

«PriceWaterhouseCoopers Ltd» performs since 1992 the function of external auditor of the Group. Before that, the predecessor organizations already served as auditors for the Group and many of its companies. Gerhard Siegrist, as head auditor (Engagement Partner), has been responsible for the audit and Group audit since the 2011 accounting year.

8.2 Auditing fees and additional fees (incl. 8.3)

The following auditor's fees have been charged to the 2014 annual accounts:

(CHF million)	Audit	Taxes	Other Services	Total
PriceWaterhouseCoopers	4.2	0.3	0.2	4.7
Other Auditing Companies	0.9	0.5	0.7	2.1
Total 2014	5.1	0.8	0.9	6.8
Total 2013	5.0	0.7	0.8	6.5

8.4 Supervisory and control instruments pertaining to the audit

The supervision and final verification of the external audit is exercised by the Audit Committee, and by the full Board of Directors, respectively (see also the duties and functions as described under 3.5). The Audit Committee evaluates together with the Group Management the performance of the auditors and recommends the independent external auditor to the Board of Directors for election by the General Assembly. The Audit Committee meets annually with the auditors. The auditors prepare a report for the Audit Committee regarding the findings of the audit, the financial statement and the internal control. At the annual meeting the audit focus points for the following review period are determined and the audit related key risks established by the auditors are discussed. In collaboration with Group Management the independence of the auditors is evaluated annually. In particular and for this purpose the worldwide fees of the audit are presented, discrepancies with the estimated costs analysed and explained and the budget for the following audit period is determined. The appointment of the auditor is subject to an approval procedure.

CORPORATE GOVERNANCE

9. Information policy

The Swatch Group reports on the business of the Group at the following times:

- February 5, 2015 Key figures 2014
- March 12, 2015 Press conference and annual report
- May 28, 2015 General Meeting of Shareholders
- August 6, 2015 Half-year figures 2015

The information is always published in the Swiss and international press and also published and processed in the publications of leading international banks.

This information can also be obtained from the Swatch Group website at www.swatchgroup.com, and in particular under the «Investor Relations» section. The annual report can also be viewed and downloaded using the link www.swatchgroup.com/annual_report. In addition, the swatchgroup.com homepage allows for the possibility of subscribing to the Push-and-Pull information service in order to receive ad-hoc-financial announcements.

For queries, there is a contact form at www.swatchgroup.com/contactus. Queries may also be sent by post (The Swatch Group Ltd., Seedorstadt 6, CH-2501 Biel) or by fax to +41 32 343 69 11 or by telephone on +41 32 343 68 11.

FINANCIAL STATEMENTS 2014

CONSOLIDATED
FINANCIAL
STATEMENTS

FINANCIAL
STATEMENTS
OF THE HOLDING



TABLE OF CONTENTS

Consolidated financial statements	156–205
Financial review	157
Consolidated income statement	163
Consolidated balance sheet	164
Consolidated statement of cash flows	166
Consolidated statement of changes in equity	167
Notes to the consolidated financial statements	168–204
1. General information	168
2. Summary of significant accounting policies	168
3. Financial risk management	176
4. Segment information	177
5. Revenues and expenses	180
6. Income taxes	181
7. Earnings per share	183
8. Dividends paid and proposed	183
9. Cash and cash equivalents	184
10. Marketable securities and derivative financial instruments	184
11. Trade receivables	185
12. Other current assets	185
13. Inventories	186
14. Prepayments and accrued income	186
15. Property, plant and equipment	187
16. Intangible assets	188
17. Investments in associates and joint ventures	189
18. Business combinations	189
19. Other non-current assets	191
20. Financial debts and derivative financial instruments	192
21. Other liabilities	192
22. Accrued expenses	193
23. Provisions	193
24. Retirement benefit obligations	194
25. Commitments and contingencies	195
26. Share capital and reserves	196
27. Acquired goodwill	197
28. Details to the consolidated statement of cash flows	198
29. Employee stock option plan	198
30. Related party transactions	199
31. Events after the balance sheet date	200
32. The Swatch Group Companies	201
Report of the statutory auditor on the consolidated financial statements	205
Financial statements of the Holding	206–216
The Swatch Group Ltd securities	217

FINANCIAL REVIEW

Key financial developments in 2014

- **Gross sales:** Gross sales for the Group exceed CHF 9 billion for the first time, a plus of 4.6% over the previous year, despite negative exchange rate impact. In the Watch & Jewelry segment, without Production, gross sales increase by 5.6%, and net sales by 3.9%.

- **Net sales:** Growth of 3.0% to CHF 8 709 million in net sales.

- **Operating profit:** Operating profit of CHF 1 752 million and operating margin of 20.1% (previous year 27.4% including the one-time special effect of the compensation of over CHF 400 million related to the Tiffany case). In the second half of 2014, deliberate increase in marketing investments in growth markets USA, Japan and Mainland China, with an impact of over 3 percentage points on the operating margin.

- **Net income:** Net income of CHF 1 416 million, with a return on net sales of 16.3% (previous year 22.8% also including the special effect of Tiffany).

- **Headcount:** Creation of over 2 100 new jobs, of which 770 in Switzerland.

- **Equity:** Equity increases to CHF 10.7 billion, equivalent to an increase in the previous year's equity ratio of 82.3% to 83.7% in 2014.

- **Dividend:** Despite the currency turbulence, an unchanged dividend of CHF 7.50 per bearer share and CHF 1.50 per registered share will be proposed.

Financial review

1. Key figures Group	(CHF million)	2014	2013	Change in %		Total
				at constant rates	currency effect	
Gross sales		9 219	8 817	+ 6.1%	– 1.5%	+ 4.6%
Net sales		8 709	8 456	+ 4.5%	– 1.5%	+ 3.0%
Operating profit		1 752	2 314			– 24.3%
– in % of net sales		20.1%	27.4%			
Net income		1 416	1 928			– 26.6%
– in % of net sales		16.3%	22.8%			
Equity		10 674	9 574			+ 11.5%
– as % of total assets		83.7%	82.3%			

FINANCIAL REVIEW

2. Environment /
Financial year

Development operating results

(CHF million)	2014			2013		
	Third	Group	Total	Third	Group	Total
Gross sales						
Watches & Jewelry	8 935	1	8 936	8 531	1	8 532
Electronic Systems	277	22	299	279	20	299
Corporate and elimination	7	-23	-16	7	-21	-14
Total	9 219	-	9 219	8 817	-	8 817
Net sales						
Watches & Jewelry	8 428	1	8 429	8 172	1	8 173
Electronic Systems	274	22	296	277	20	297
Corporate and elimination	7	-23	-16	7	-21	-14
Total	8 709	-	8 709	8 456	-	8 456
Operating result						
	2014	% of		2013	% of	
		sales			sales	
Watches & Jewelry	1 860	22.1%		2 424	29.7%	
Electronic Systems	-9	-3.0%		-12	-4.0%	
Corporate and elimination	-99			-98		
Total	1 752	20.1%		2 314	27.4%	

The Swatch Group, with its 20 brands, generated gross sales of CHF 9 219 million in 2014, growing a further 4.6%, and net sales increased 3.0% to CHF 8 709 million, despite the ongoing and extremely difficult currency situation which impacted gross sales with a negative exchange rate effect of CHF 138 million over the entire year. In addition, the fire at ETA already negatively affected sales in the first half year of 2014 by approximately CHF 200 million.

In Watches & Jewelry, without Production, growth in gross sales of 5.6% and in net sales of 3.9% was generated, despite an ongoing long-term defensive price adjustment policy. In comparison, exports of wristwatches for the entire Swiss watch industry to the end of December 2014 increased by 1.7%, which in turn indicates a clear gain again in market share by the Swatch Group. This underscores the long-term strategy followed by the Group, which is characterized by a defensive price adjustment policy and a high level of investment, in contrast to short-term profit thinking. Therefore, all brands deliberately undertook more marketing investment, not only in the first half 2014 during the Olympic Winter Games in Sochi, but also in the second half of the year, by investing in the growth markets of the USA, Japan and Mainland China. In particular, Omega signed a renewal contract until 2022 for the US PGA Golf tour, and Longines massively increased its presence in equestrianism, mainly in Japan and the USA.

In the year under review, production ramped up in the new plants in Boncourt, Grenchen and Villeret. Also, the new Universo plant in La Chaux-de-Fonds started production. In connection with the fire at ETA, the production flow was newly defined and reorganized in order to rule out, as far as possible, any such interruption in future, particularly in the electroplating department. As expected, there were far fewer adverse effects resulting from the fire in the production at ETA in the second half of the year than there were in the first half. As a result, production could again be stabilized as of November, however, lost production and additional costs due to the fire could not be recovered.

The Electronic Systems segment generated gross sales growth of 9.0% in the second half of 2014, adjusted for the disposal of Oscilloquartz SA, which is an extremely positive result in view of strong price pressure and unfavorable exchange rates. This was achieved through significant innovations in batteries and integrated circuits. The latter also recorded higher sales volumes, driven by electronic consumer goods such as fitness bands, for example, which brought sales in this segment to CHF 299 million. The companies of the Swatch Group belong to the most innovative players worldwide in the Smart Objects sector, and the list of well-known smart and mobile device producers which these Swatch Group companies supply with components is long.

In 2014, the Group's operating profit reached CHF 1 752 million, reflecting an operating margin of 20.1%.

FINANCIAL REVIEW

Development net income

(CHF million)	2014	2013
Interest income	7	28
Result from marketable securities at fair value	12	29
Net currency result	-2	-27
Other financial expense	-4	-5
Interest expense	-2	-2
Share of result from associates and joint ventures	3	13
Net financial result	14	36

(CHF million)	2014	2013
Net income	1 416	1 928
- in % of net sales	16.3%	22.8%
- Change from previous year in %	-26.6%	20.2%
Basic earnings per share – expressed in CHF per share:		
- Registered shares	5.10	7.08
- Bearer shares	25.49	35.41

In the year under review, the net financial result was CHF 14 million (compared to CHF 36 million in 2013). The decrease is mainly due to lower interest income and reduced earnings from marketable securities at fair value. However, an almost balanced net foreign exchange result was achieved (2013 resulted in a foreign exchange loss of CHF 27 million). With the decision of the Swiss National Bank on 15 January 2015 to abandon the Euro minimum exchange rate after three years, the negative exchange rate impact for 2015 was already anticipated.

In relation to the profit before taxes, the income tax charge amounted to 19.8% in the reporting year, compared to 18.2% in the previous year. An analysis of the income tax charge is set out in Note 6 of the consolidated financial statements.

Overall, net income was CHF 1 416 million, which corresponds to a 16.3% net return on sales.

Basic earnings per share amounted in the current year to CHF 5.10 (2013: CHF 7.08) for registered shares and CHF 25.49 (2013: CHF 35.41) for bearer shares, respectively. As in previous years, dilution of earnings is not material. Detailed information can be found in Note 7.

Group wide, over 2 100 new jobs were created. Switzerland alone accounted for 770 new jobs, mainly in the production area and to a lesser extent in the retail business. This underscores the Group's commitment to its manufacturing base Switzerland as well as the further strengthening of "Swiss Made". In total, Swatch Group employed more than 35 500 employees at the end of December 2014.

The 2014 result and the current outlook for 2015 have prompted the Board of Directors of the Swatch Group to propose an unchanged high dividend of CHF 7.50 per bearer share and CHF 1.50 per registered share at the Annual General Meeting on 28 May 2015.

FINANCIAL REVIEW

Development balance sheet structure

(CHF million)	2014	2013
Total current assets	8 946	8 673
Total current liabilities	1 308	1 338
Equity	10 674	9 574
– as % of total assets	83.7%	82.3%
Average return on equity (ROE)	14.0%	21.2%

Current liabilities are covered by current assets by a factor of 6.8 (2013: 6.5). This factor shows that the consolidated balance sheet is very solid.

As per end of December 2014 equity increased to CHF 10.7 billion to an extremely solid capitalization, with an equity ratio of 83.7%.

Development liquidity

(CHF million)	2014	2013
Cash and cash equivalents at 1.1.	908	1 520
Cash flow from operating activities	1 848	1 309
Cash flow from investing activities	– 1 122	– 1 309
Cash flow from financing activities (incl. foreign exchange rate differences on cash)	– 432	– 612
Cash and cash equivalents at 31.12.	1 202	908

Operating cash flow of CHF 1 848 million was very high due to the very good incoming payments over the course of the entire year, although there was still consistent investment in inventories. The latter went mainly to expansion of the Harry Winston brand, the launch of the new Omega Master Co-Axial with anti-magnetic movement, the preparation for the worldwide launch of the new AluSwatch XLite and the opening of new monobrand stores.

In addition, approximately 10% more was invested in facilities, production and retail stores than in the previous year. Including the acquisition of the Peterhof commercial building on the Bahnhofstrasse in Zurich made at the end of the year, total investments reached CHF 1 203 million. This represents approximately 70% more than the previous year, of which CHF 867 million in Switzerland.

The dividend payment of CHF 407 million (2013: CHF 366 million) was the main cash flow from financing activities.

Overall, the Group's cash position increased in 2014 by CHF 294 million to CHF 1 202 million at year-end.

FINANCIAL REVIEW

3. Outlook

After a strong December 2014 in Swiss francs, 2015 started very auspiciously with a strong January, of course computed in local currency. With the decision of the Swiss National Bank on 15 January 2015 to abandon the Euro minimum exchange rate after three years and to introduce higher negative interest on current accounts, the negative exchange rate impact for 2015 was already anticipated; within a day the Swiss franc rose to parity with or even slightly higher than the Euro.

With its 20 brands, its own production and its worldwide distribution network, the Group is in a very strong position. Marketing investments and selling expenses in foreign currencies, or companies such as Harry Winston in the USA or Rivoli in the Middle East, whose costs are also recorded in local currency, absorb part of the negative effect of the overvalued Swiss franc. In addition, several Group brands are reacting with price adjustments of between 5% and 7% in select markets, which will also compensate for the very unfavorable currency situation.

The number of Swatch Group patent applications reached a new record again in 2014; this will be reflected in the numerous innovative product launches in all segments in 2015.



CONSOLIDATED INCOME STATEMENT

	Notes	2014		2013	
		CHF million	%	CHF million	%
Gross sales		9 219	105.9	8 817	104.3
Sales reductions		- 510	- 5.9	- 361	- 4.3
Net sales	(4, 5a)	8 709	100.0	8 456	100.0
Other operating income	(5b)	231	2.6	518	6.1
Changes in inventories		397	4.6	586	6.9
Material purchases		- 2 240	- 25.7	- 2 456	- 29.0
Personnel expense	(5c)	- 2 343	- 26.9	- 2 144	- 25.3
Depreciation on tangible assets	(15)	- 324	- 3.7	- 276	- 3.3
Amortization on intangible assets	(16)	- 34	- 0.4	- 28	- 0.3
Other operating expenses	(5d)	- 2 644	- 30.4	- 2 342	- 27.7
Operating profit		1 752	20.1	2 314	27.4
Other financial income and expense	(5f)	13	0.2	25	0.3
Interest expense	(5f)	- 2	- 0.0	- 2	- 0.0
Share of result from associates and joint ventures	(5f, 17)	3	0.0	13	0.1
Ordinary result		1 766	20.3	2 350	27.8
Non-operating result	(5g)	- 1	- 0.0	6	0.1
Extraordinary result		-	0.0	-	0.0
Profit before taxes		1 765	20.3	2 356	27.9
Income taxes	(6a)	- 349	- 4.0	- 428	- 5.1
Net income		1 416	16.3	1 928	22.8
Attributable to equity holders of The Swatch Group Ltd		1 384		1 921	
Attributable to non-controlling interests		32		7	
Earnings per share (EPS) – expressed in CHF per share:	(7)				
Registered shares					
Basic earnings per share		5.10		7.08	
Diluted earnings per share		5.09		7.08	
Bearer shares					
Basic earnings per share		25.49		35.41	
Diluted earnings per share		25.47		35.38	

The accompanying notes form an integral part of the consolidated financial statements.

CONSOLIDATED BALANCE SHEET

Assets	Notes	31.12.2014		31.12.2013	
		CHF million	%	CHF million	%
Current assets					
Cash and cash equivalents	(9)	1 202	9.4	908	7.8
Marketable securities and derivative financial instruments	(10)	263	2.1	325	2.8
Trade receivables	(11)	1 108	8.7	1 073	9.2
Other current assets	(12)	135	1.1	256	2.2
Inventories	(13)	5 943	46.6	5 426	46.6
Prepayments and accrued income	(14)	295	2.3	685	5.9
Total current assets		8 946	70.2	8 673	74.5
Non-current assets					
Property, plant and equipment	(15)	3 010	23.6	2 272	19.5
Intangible assets	(16)	150	1.2	136	1.2
Investments in associates and joint ventures	(17)	70	0.5	65	0.6
Other non-current assets	(19)	201	1.6	156	1.3
Deferred tax assets	(6d)	370	2.9	337	2.9
Total non-current assets		3 801	29.8	2 966	25.5
Total assets		12 747	100.0	11 639	100.0

The accompanying notes form an integral part of the consolidated financial statements.

CONSOLIDATED BALANCE SHEET

Equity and liabilities	Notes	31.12.2014		31.12.2013	
		CHF million	%	CHF million	%
Current liabilities					
Financial debts and derivative financial instruments	(20)	35	0.3	15	0.1
Trade payables		371	2.9	383	3.3
Other liabilities	(21)	158	1.2	164	1.4
Provisions	(23)	83	0.7	74	0.6
Accrued expenses	(22)	661	5.2	702	6.1
Total current liabilities		1 308	10.3	1 338	11.5
Non-current liabilities					
Financial debts	(20)	38	0.3	44	0.4
Deferred tax liabilities	(6d)	604	4.7	576	4.9
Retirement benefit obligations	(24)	38	0.3	33	0.3
Provisions	(23)	47	0.4	45	0.4
Accrued expenses	(22)	38	0.3	29	0.2
Total non-current liabilities		765	6.0	727	6.2
Total liabilities		2 073	16.3	2 065	17.7
Equity					
Share capital	(26a)	125		125	
Capital reserves	(26b)	- 1 037		- 1 062	
Treasury shares	(26c)	- 301		- 268	
Goodwill recognized		- 1 372		- 1 369	
Translation differences		- 6		- 115	
Retained earnings		13 174		12 197	
Equity of The Swatch Group Ltd shareholders		10 583	83.0	9 508	81.7
Non-controlling interests		91	0.7	66	0.6
Total equity		10 674	83.7	9 574	82.3
Total equity and liabilities		12 747	100.0	11 639	100.0

The accompanying notes form an integral part of the consolidated financial statements.

CONSOLIDATED STATEMENT OF CASH FLOWS

	Notes	2014 CHF million	2013 CHF million
Operating activities			
Net income		1 416	1 928
Reversal of non-cash items	(28a)	739	712
Changes in working capital and other items included in operating cash flow	(28b)	92	- 965
Dividends received from associated companies	(17)	3	21
Interest received		28	9
Interest paid		- 2	- 4
Income tax paid	(6c)	- 428	- 392
Cash flow from operating activities		1 848	1 309
Investing activities			
Investments in property, plant and equipment	(15)	- 1 040	- 574
Proceeds from sale of property, plant and equipment		4	19
Investments in intangible assets	(16)	- 48	- 48
Proceeds from sale of intangible assets		1	-
Investments in other non-current assets	(19)	- 115	- 84
Proceeds from sale of other non-current assets		2	10
Acquisition of subsidiaries – net of cash	(18)	- 4	- 759
Divestments of businesses	(18)	3	-
Investments in associated companies and joint ventures	(17)	-	- 14
Divestments of associated companies and joint ventures		-	0
Purchase of marketable securities		- 187	- 207
Sale of marketable securities		262	348
Cash flow from investing activities		- 1 122	- 1 309
Financing activities			
Dividends paid to shareholders	(8)	- 407	- 366
Dividends paid to non-controlling interests		- 14	- 5
Purchase of treasury shares	(26b)	- 107	- 2
Sale of treasury shares		78	123
Change in non-current financial debts		- 5	- 260
Change in current financial debts		- 1	- 88
Cash flow from financing activities		- 456	- 598
Net impact of foreign exchange rate differences on cash		24	- 14
Change in cash and cash equivalents		294	- 612
Change in cash and cash equivalents			
– At beginning of year		908	1 520
– At end of year	(9)	1 202	908
		294	- 612

The accompanying notes form an integral part of the consolidated financial statements.

CONSOLIDATED STATEMENT OF CHANGES IN EQUITY

(CHF million)	Attributable to The Swatch Group Ltd shareholders						Total	Non-con- trolling interests	Total equity
	Share capital (Note 26)	Capital reserves (Note 26)	Treasury shares (Note 26)	Goodwill recognized ¹⁾	Translation differences	Retained earnings ¹⁾			
Balance at 31 December 2012	125	- 1 128	- 343	- 701	- 41	10 642	8 554	19	8 573
Net income						1 921	1 921	7	1 928
Currency translation of foreign entities					- 74		- 74	- 1	- 75
Compensation of goodwill Group companies (Note 18)				- 668			- 668		- 668
Minority interests from business combinations (Note 18)								46	46
Dividends paid						- 366	- 366	- 5	- 371
Share-based compensation (Note 29):									
– Value of employee services (net of tax)		20					20		20
– Proceeds from sale of shares		1					1		1
Sale of treasury shares		45	77				122		122
Repurchase of treasury shares			- 2				- 2		- 2
Balance at 31 December 2013	125	- 1 062	- 268	- 1 369	- 115	12 197	9 508	66	9 574
Net income						1 384	1 384	32	1 416
Currency translation of foreign entities					109		109	7	116
Compensation of goodwill Group companies (Note 18)				- 3			- 3		- 3
Dividends paid						- 407	- 407	- 14	- 421
Share-based compensation (Note 29):									
– Value of employee services (net of tax)		21					21		21
– Proceeds from sale of shares		1					1		1
Sale of treasury shares		3	74				77		77
Repurchase of treasury shares			- 107				- 107		- 107
Balance at 31 December 2014	125	- 1 037	- 301	- 1 372	- 6	13 174	10 583	91	10 674

¹⁾ As of 31 December 2012 goodwill from acquisitions is no longer offset against retained earnings but is recognized in a separate position in the statement of changes in equity.

The accompanying notes form an integral part of the consolidated financial statements

NOTES TO THE CONSOLIDATED FINANCIAL STATEMENTS

1. General information

The Swatch Group Ltd (the Company) and its subsidiaries (collectively the Group) is active worldwide and represented in the finished watches and jewelry sector with 20 brands in all market and price segments. In addition, it holds an outstanding industrial position with a high degree of vertical integration in the sector of watch movements and components as well as in the electronic systems sector.

The Company is a limited company incorporated and domiciled in Switzerland. Its registered office is located in Neuchâtel, Faubourg de l'Hôpital 3. The administrative headquarters are in Biel, Seedorf 6.

The shares of The Swatch Group Ltd are listed in Switzerland on the Main Market of the SIX Swiss Exchange, under the ISIN numbers CH0012255144 (registered shares) and CH0012255151 (bearer shares). Bearer shares are included in the indices SMI, SPI as well as SLI and registered shares in the indices SPI, SPI Extra and SMIM. In addition, Swatch Group shares are also listed on the BX Berne eXchange.

These consolidated financial statements were approved for issue by the Board of Directors on 20 February 2015 and will be submitted to the Annual General Meeting of Shareholders for approval on 28 May 2015.

2. Summary of significant accounting policies

a. Basis of preparation

These financial statements provide a true and fair view of the Swatch Group's assets, financial position and earnings, and have been drawn up in accordance with all of the existing guidelines of the accounting and reporting recommendations of Swiss GAAP FER. The Group already adopted FER 31 for listed companies (published in January 2013 and applicable as of 1 January 2015) as of 1 January 2013. The financial statements of the Group are based upon the financial statements of the Group companies as at 31 December and are established in accordance with the standardized reporting and accounting policies. The financial statements are based on the principle of historical acquisition costs (except for securities and derivative financial instruments recognized at fair value) and on the going concern principle. The statements are presented in Swiss francs (CHF). Unless otherwise indicated, all amounts have been rounded to the next million.

b. Consolidation policies

The Group companies include all companies that are directly or indirectly controlled by The Swatch Group AG. In this respect, control is defined as the power to control the financial and operating activities of the respective company, so as to obtain benefits from its operations. This control is normally evidenced by the holding of more than half of the voting rights on share capital of an entity. Group companies are consolidated from the date on which control is transferred to the Group. Subsidiaries intended for disposal are excluded from the consolidation from the date on which control ceases.

Companies acquired over the course of the year are revalued and consolidated in accordance with Group principles upon the date of acquisition. The difference between the acquisition costs and the proportional revalued net assets is referred to as goodwill. Within the scope of acquisitions, potentially existing but until now not capitalized intangible assets such as brands, usage rights and client lists are not recognized separately, but instead remain part of goodwill. Goodwill may also arise from investments in associated companies and is defined as the difference between the acquisition costs of the investment and its proportional revalued net assets. The goodwill resulting from acquisitions is recognized directly in Group equity. The Notes to the financial statements disclose the effects that a theoretical capitalization and amortization of the acquired goodwill would have (see Note 27).

In the event that shares of Group or associated companies are sold, the difference between the proceeds from the sale and the proportional book value of the net assets, including historical goodwill, is recognized as a gain or loss in the income statement. Non-controlling interests in equity and in net income are disclosed separately in the consolidated balance sheet and the consolidated income statement. Changes in ownership interests in subsidiaries are recognized as equity transactions, provided that control continues. Intercompany transactions, balances and unrealized gains and losses from transactions between Group companies are eliminated in full.

Associates are all companies on which the Group exerts significant influence, but does not control. This is generally evidenced when the Group holds voting rights of 20% to 50% of a company. Representation on the board of directors or access to the current financial information of a company are also indicators of significant influence. Investments in associated companies are accounted for using the equity method and are initially recognized at cost. Unrealized gains and losses from transactions with associated companies are eliminated to the extent of the Group's participation in the associated company. The accounting policies of associated companies are adjusted where necessary in order to ensure consistency with the policies observed by the Group. Participations in joint ventures are also reported using the equity method.

NOTES TO THE CONSOLIDATED FINANCIAL STATEMENTS

- c. Scope of consolidation** At 31 December 2014, the Group's consolidation structure comprised 172 legal entities (previous year: 185) including two joint ventures (previous year: two) and six associated companies (previous year: six). The decrease resulted primarily from Group internal mergers and liquidations. Information on acquisitions and disposals of companies is available in Note 18. Note 32 includes a complete list of Group companies.
- d. Accounting estimates and judgments** The preparation of consolidated financial statements in conformity with Swiss GAAP FER requires the use of certain accounting estimates and judgments. Estimates and judgments are continuously evaluated and are based on historical experience and other factors, including expectations of future events that are assumed to be reasonable under the given circumstances. Real results may differ from these estimates. Management continuously reviews and, if necessary, adapts the estimates and underlying assumptions. Any changes are recognized in the period in which the estimate is revised.
- e. Changes in accounting policies**
- Changes not yet in force to existing Standards**
The Group did not adopt early the following changes to existing Standards which were published by the end of 2014 and which are binding as of 1 January 2015 or later:
- New guideline on revenue recognition: changes in Swiss GAAP FER Framework, FER 3 and FER 6**
New rules in the area of revenue recognition specify how revenue is to be recognized, valued and disclosed. To this end, the Framework, FER 3 and FER 6 were adapted. The amendments stipulate that revenue is to be recognized when a service was provided or an asset was delivered, and the risks and rewards as well as the control have been transferred to the purchaser. In addition, net revenues from sales and services are defined as revenues from ordinary business activities which include the value of the services provided, less sales reductions. In the case of agents, only the value of own services performed is to be recognized. Separately identifiable elements of business transactions are to be recognized and valued separately. In addition, the most significant sources of revenue and their recognition are to be disclosed in the notes. The new rules come into force on 1 January 2016 (early adoption is permitted). The Group is currently evaluating the effect of these changes, but anticipates no major impact on the manner in which the Group recognizes revenue.

NOTES TO THE CONSOLIDATED FINANCIAL STATEMENTS

f. Foreign currency translation

Translation in the financial statements of the Group companies

The financial statements of individual Group companies are measured in the currency of the economic environment in which these companies predominantly operate (functional currency). Transactions in foreign currencies are converted to the functional currency at the prevailing exchange rate on the transaction date. Balance sheet items in foreign currency are converted using the year-end exchange rate. Any resulting gains and losses are recorded in the income statement. Foreign exchange gains or losses from the conversion of intercompany loans of an equity nature are recognized in equity without affecting the income statement. Exchange differences resulting from the conversion of investments in associated companies are also reported in equity. There are no investments in hyperinflationary countries.

Translation of individual financial statements to be consolidated

The financial statements of the Swatch Group are presented in the reporting currency of Swiss francs (CHF). The financial statements of the individual companies to be consolidated are translated into Group currency at the effective date with the current rate method. This currency translation is carried out for the assets and liabilities at the year-end exchange rates, for equity at historical exchange rates, and for the income statement and statement of cash flows at average annual exchange rates. Any translation differences are recognized in equity without affecting the income statement.

In the event that a foreign entity is sold, the cumulative translation differences recognized in equity, which are a result of the translation of the financial statements and intercompany loans, are reversed from the accounts and reported in the income statement as part of the gain or loss on the sale.

The main exchange rates used are:

Currency	Unit	Average rates	Prevailing rates	Average rates	Prevailing rates
		2014	31.12.2014	2013	31.12.2013
		CHF	CHF	CHF	CHF
CNY	1	0.1496	0.1598	0.1510	0.1475
EUR	1	1.2139	1.2030	1.2317	1.2280
HKD	1	0.1190	0.1277	0.1196	0.1152
JPY	100	0.8683	0.8300	0.9499	0.8500
USD	1	0.9226	0.9905	0.9277	0.8930

g. Sales and revenue recognition

The Group records the gross amounts of invoices for sales of goods and services, excluding VAT, as gross sales. All differences between the gross amounts invoiced and the agreed net price, such as rebates and price reductions, are recorded as sales reductions. Net sales comprise the fair value of the sale of goods and services, and therefore represent revenue.

All intercompany sales are eliminated upon consolidation.

Revenues are reported if a Group company has transferred the significant risks and rewards of ownership of products sold to the client, and the collectability of the related receivables is reasonably secured. Accruals for discounts granted to clients are established during the same period as the sales which gave rise to the discounts under the terms of the contract. Revenue from services is recognized in the accounting period in which the service is rendered.

h. Cash and cash equivalents

Cash and cash equivalents in the balance sheet comprise petty cash, cash at banks and short-term deposits with an original maturity of three months or less. They are recorded at their nominal value. In the cash flow statement, cash and cash equivalents consist of cash and cash equivalents as defined above, less current account overdrafts (Fund "Net Cash").

NOTES TO THE CONSOLIDATED FINANCIAL STATEMENTS

i. Marketable securities Purchases and sales of securities are recognized in accordance with the settlement date principle. The securities are initially measured at cost, and the transaction costs are charged to the income statement. Subsequently, the listed securities are recorded in the balance sheet at market value on the balance sheet date. Private equity investments are adjusted to the current net asset value on the balance sheet date. All realized and unrealized gains and losses resulting from variations in market values and foreign currencies are recorded in the income statement.

j. Trade receivables Trade receivables are recognized and carried at the original net invoice amount less an allowance for any specifically impaired receivables. Provision is made for balances overdue more than 12 months or for receivables where specific risks have been identified. Bad debts are written off when there is objective evidence that the Group will not be able to collect the receivables.

k. Inventories Inventories are valued at the lower of cost or net realizable value. Any discounts received are treated as cost reductions. Manufacturing costs comprise all costs directly attributable to material and production, as well as overhead costs incurred in building up the inventory at its current location and/or to its current condition. Acquisition costs are determined according to the weighted average method. Some production companies value their inventories using the standard cost method. As these costs are regularly reviewed and updated, this method approximates the result of the weighted average method. Inventories with unsatisfactory inventory turnover are revalued accordingly.

l. Property, plant and equipment Property, plant and equipment (including investment property) are recorded in the balance sheet at historical cost less accumulated depreciation and any impairments. Acquisition costs comprise the purchase price as well as the costs directly attributable to the utilization of the property, plant and equipment. Investments in existing property, plant and equipment are only capitalized if their value in use is sustainably increased or their useful life is extended considerably. Self-constructed assets are only capitalized if they are clearly identifiable and the costs can be reliably determined, and if the assets generate measurable benefits for the Group over a period of several years. Maintenance and repair costs that do not add value are charged directly to the result for the period.

Depreciation is calculated on a straight-line basis over the estimated useful life of the assets, as follows:

– Land	no depreciation
– Investment properties	50 years
– Administrative buildings	40 years
– Production plants and workshop buildings	30 years
– Machines and technical equipment, workshop equipment	9 to 15 years
– Measuring instruments, tools, processing equipment, automation components	5 to 9 years
– Furniture, office machinery, motor vehicles	5 to 8 years
– IT equipment	3 to 5 years

The residual values and the remaining useful life of property, plant and equipment are reviewed yearly and adjusted where necessary. Investment property mainly comprises residential buildings rented to third parties. The position Plant and equipment under construction includes buildings under construction and non-refundable down payments on land and buildings. The Group does not capitalize any interest expenses incurred during the construction period.

NOTES TO THE CONSOLIDATED FINANCIAL STATEMENTS

m. Intangible assets

Goodwill

The difference between the acquisition costs and the actual value of the net identifiable assets of the acquired company at the time of the purchase represents goodwill from business combinations. The goodwill resulting from acquisitions is recognized in Group equity at the time of the acquisition. The Notes to the financial statements disclose the effects that a theoretical capitalization and amortization of the goodwill would have (see Note 27).

Goodwill may also arise from investments in associated companies, calculated as the difference between the acquisition costs of the investment and its proportional revalued net assets.

Capitalized development costs

Research costs are expensed when incurred. Development costs are only capitalized if they can be identified as intangible assets that will generate economic benefits in the future and the costs can be measured reliably. Other development costs are expensed when incurred. Once a product enters commercial production, the capitalized development costs are amortized on a straight-line basis over the estimated useful life (max. five years).

Other intangible assets

In addition, the heading intangible assets includes:

- Licences purchased granting rights to use new technologies and software. They are amortized over their useful life (max. five years).
- Internally developed software and software implementation costs. These costs are recognized as intangible assets if it is likely that they will generate future economic benefits. The costs include software development employee costs and the direct portion of related overhead costs. The capitalized costs are amortized on a straight-line basis over the estimated useful life (max. five years).
- Key money for strategically located retail stores. If its value can be demonstrated by the existence of a market, it is capitalized as an intangible asset and amortized on a straight-line basis over the location's useful life of max. 20 years. In contrast, key money that is not refundable or only refundable under specific circumstances is treated as prepaid rent and recorded under Other non-current assets (see Note 19).

n. Impairment of assets

The recoverable value of non-current assets (including goodwill recognized in equity) is verified on every balance sheet date. If there are indications of a sustained impairment, the recoverable amount of the respective assets will be determined. The recoverable amount is the higher of the net selling price and value in use.

If the recoverable amount of an individual asset cannot be determined, the Group estimates the recoverable amount of the smallest group of assets to which the individual asset belongs. If the book value of an asset exceeds the recoverable amount, an impairment loss is recognized separately in the income statement. As the goodwill is already recognized in equity at the time at which it was acquired, a goodwill impairment would not result in a charge being recorded in the income statement, but leads to a disclosure in the Notes to the financial statements. In the event that a Group company is sold, any goodwill acquired at an earlier point in time and recognized in equity is taken into consideration when determining the gain or loss in the income statement.

NOTES TO THE CONSOLIDATED FINANCIAL STATEMENTS

o. Provisions

Provisions are recognized:

- when the Group has a present legal or constructive obligation as a result of past events
- when it is probable that an outflow of resources will be required to settle the obligation, and
- when a reliable estimate of the amount of the obligation can be made.

Where the Group expects some or all of a provision to be reimbursed, for example under an insurance contract, the reimbursement is recognized as a separate receivable, but only when the reimbursement is virtually certain. The expense relating to any provision is presented in the income statement, net of any reimbursement. If the effect of the time value of money is material, provisions are discounted, using a current discount rate that reflects, where appropriate, the risks specific to the liability. Where discounting is used, the increase in the provision in function of time is recognized as interest expense.

p. Financial debts

Financial debts are recognized as nominal values. Any transaction costs incurred are posted directly in the income statement. Financial debts are shown on the balance sheet as current liabilities, unless the Group has an unconditional right to postpone the settlement of the debt until at least 12 months after the balance sheet date.

q. Derivative financial instruments

Derivative financial instruments are recognized at fair value at the trade date; the associated transaction costs are recorded as expenditure in the income statement. The method of recognizing the gain or loss from subsequent revaluations depends on the purpose for the hedging and the underlying transaction.

Cash flow hedges

The Group may hedge certain cash flows for projected intragroup transactions. This is documented accordingly upon conclusion of the transaction. In this case, the effective portion of changes in the fair value of derivatives that are designated as cash flow hedges is recognized in equity. The gain or loss relating to the ineffective portion is recognized immediately in the income statement under financial result.

Amounts recognized in equity are recycled in the income statement in the periods when the hedged item affects gain or loss. The gain or loss from the effective portion of the hedging instrument related to flow of goods is recorded in the income statement under material purchases.

When a forecasted transaction is no longer expected to occur, the cumulative gain or loss reported in equity is immediately transferred to the income statement.

Other derivative financial instruments

Derivative financial instruments not designated as hedging instruments are accounted for at fair value through gain or loss. Changes in the fair value are recognized immediately in the income statement.

r. Income taxes

The tax expense for the period comprises current and deferred tax. Tax is recognized in the income statement, except to the extent that it relates to items recognized directly in equity. In this case, the tax is also recognized directly in equity.

Current income tax

Current tax liabilities and assets for the current and prior periods are measured at the amount expected to be paid to or recovered from the taxation authorities. The tax rates and tax laws used to compute the amount are those that are enacted or substantively enacted at the balance sheet date.

NOTES TO THE CONSOLIDATED FINANCIAL STATEMENTS

Deferred tax

Deferred tax is recognized in full, using the balance sheet approach, on temporary differences arising between the tax bases of assets and liabilities and their carrying amounts in the financial statements.

Deferred tax is determined using tax regulations and rates that have been enacted or substantively enacted by the balance sheet date and are expected to apply.

Deferred tax assets are recognized for all deductible temporary differences, carryforward tax losses and tax credits to the extent that it is probable that future taxable profits will be available against which they can be utilized.

Deferred tax is recognized on temporary differences arising on investments in subsidiaries and associates, except where the timing of the reversal of the temporary difference is controlled by the Group and it is not intended that the temporary difference will reverse in the foreseeable future.

Deferred tax assets and deferred tax liabilities are offset if a legally enforceable right exists to offset current tax assets against current tax liabilities and the deferred taxes relate to the same taxable entity and the same taxation authority.

s. Pensions and other post-employment benefits

Pension obligations

Group companies operate various pension schemes, which conform to the legal regulations and provisions in force in the respective countries. The actual economic effects of pension schemes on the Group are calculated at balance sheet date. An economic obligation is recognized as a liability if the requirements for the recognition of a provision are met. An economic benefit is capitalized provided that this can be used for future Group pension expenses. Freely available employer contribution reserves are capitalized.

Employees of Swiss Group companies are insured as part of the "Swatch Group Pension Fund", which is a separate legal entity and is financed by contributions from both employers and employees. Surpluses or deficits are calculated based on the Pension Fund's financial statements, which have been drawn up in accordance with Swiss GAAP FER 26. The Group's pension costs include the employer contributions accrued in the period as well as any economic effects from the excess/shortfall and the change in employer contribution reserves.

Pension schemes outside of Switzerland are of comparatively minor importance. Some companies operate fully financed pension funds. These funds are treated in the same way as the Swiss plan in terms of accounting, i.e. paid contributions are basically recorded as expenses. In some countries, there are also pension plans that do not have their own assets, whereby the corresponding benefit provisions are recognized directly in the balance sheet and any changes are recognized in the income statement.

Other post-employment benefits

A small number of Group companies provide post-retirement medical care benefits to their employees. The entitlement to these benefits is usually conditional on the employee remaining in service up to retirement age and the completion of a minimum service period. The expected costs of these benefits are accrued over the period of employment.

Termination benefits

Termination benefits are payable when employment is terminated (in normal employment conditions) in advance of the terms of the contract, or whenever an employee accepts voluntary redundancy in exchange for these benefits. The Group recognizes such benefits when it is demonstrably committed to either terminating the employment of current employees according to a detailed formal plan without the possibility of withdrawal, or providing benefits as a result of an offer made to encourage voluntary redundancy. Benefits falling due more than 12 months after the balance sheet date are discounted to present value. The company does not make severance payments.

NOTES TO THE CONSOLIDATED FINANCIAL STATEMENTS

t. Share capital and treasury shares

Shares issued by The Swatch Group AG are recognized in equity. Incremental costs directly attributable to the issue of new shares or options are shown in equity as a deduction, net of tax, from the proceeds. Share capital consists of registered shares, each with a nominal value of CHF 0.45, and bearer shares, each with a nominal value of CHF 2.25. Other than the higher voting power of registered shares, no differences in terms of shareholder rights exist between the two categories.

Own equity instruments that are reacquired (treasury shares) are deducted from equity. No gain or loss is recognized in the income statement on the purchase, sale, issue or cancellation of the Group's own equity instruments. In the event of a resale at a later point in time, a gain or loss is recognized as an addition to or reduction of capital reserves.

u. Dividends

Dividend payments to shareholders are recognized in the Group's financial statements in the period in which the Annual General Meeting of the holding company has given its approval.

v. Share-based payment transactions

The Group operates an equity-settled, share-based compensation plan. Under the terms of this plan, share options are granted to managers and employees who distinguished themselves by a particular strong commitment to the company or an above-average performance. The fair value of the employee services received in exchange for the grant of the options is recognized as an expense. The total amount to be expensed over the vesting period is determined by reference to the fair value of the options granted (market value at grant date). At each balance sheet date, the Group revises its estimates of the number of options that are expected to become exercisable. It recognizes the impact of the revision of original estimates, if any, in the income statement, and a corresponding adjustment to equity.

A block of treasury shares has been specifically reserved for this stock option plan. No new shares were issued under this plan. The proceeds received net of any transaction cost are credited to equity when the options are exercised.

The dilutive effect of outstanding options is reflected as additional share dilution in the computation of earnings per share (see Note 7).

w. Leases

Finance leases

Property, plant and equipment are only leased in exceptional circumstances. A finance lease is where the lessor transfers to the lessee practically all of the risks and rewards associated with the ownership of the leased item. At the beginning of the term of the lease contract, the lower of fair value of the leased item or net present value of the future lease payments is shown in the balance sheet as assets and liabilities. Each lease payment is apportioned between the finance charges and the reduction of the lease liability, so as to achieve a constant rate of interest on the remaining balance of the liability. Finance costs are recorded directly in the income statement as expenditure. Capitalized leased assets are depreciated over the lower of estimated economic useful life of the asset or contract period.

Operating leases

An operating lease is where a significant portion of the risks and rewards of ownership are retained by the lessor. Operating lease payments are recognized as expenses in the income statement on a straight-line basis over the lease term.

NOTES TO THE CONSOLIDATED FINANCIAL STATEMENTS

3. Financial risk management

a. Financial risk factors

In view of the global and varied nature of its activities, the Group is exposed to different financial risks, including foreign currency, market, credit and liquidity risks. The Group's financial risk management is essentially focused on identifying and analyzing exchange rate risk, mainly against the US Dollar, the Chinese Renminbi, the Euro and the Japanese Yen, with the aim of minimizing its impact on Group net income. In order to hedge exchange rate risk, the Group may use derivative financial instruments such as forward currency contracts or currency options. Currently no cash flow hedging is used.

Risk management is conducted by the central treasury department (Group Treasury), which follows the directives issued by the Group's management bodies. Risks are assessed in collaboration with the operating units and the hedging methods are decided and implemented under the regular supervision of the Group's Top Management.

Credit risk

Credit risks in respect of customers arise when they may not be able to settle their obligations as agreed. The credit standing of commercial partners defined in the Group's client credit policy is periodically reviewed at Group level. As there is no independent rating for most customers, their credit quality is assessed by local credit control departments taking into account their financial position, past experience and other factors. There is no concentration of credit risk with respect to trade receivables, as the Group has a large number of customers, internationally dispersed.

In the context of securities trading, the Group guards against the risk of default by implementing directives that impose minimum credit ratings for investments in tradable securities. In general, issuer risk is minimized by only buying securities which are investment grade rated.

Counterparty risk is also minimized by ensuring that all derivative financial instruments, money market investments and current account deposits are placed with financial institutions whose credit ratings are usually at least A-. Exposure to this type of risk is closely monitored by Group management and is contained within strict and pre-determined limits.

Given the very high standards of creditworthiness applied to the commercial and financial partners, the default risks to which the Group is exposed are estimated to be limited.

Liquidity risk

Liquidity risk is defined as the risk that the Group could not be able to meet its financial obligations on time. The close monitoring of liquidity at Group level and of the asset allocation allows the Group's treasury department to maintain adequate levels of liquidity at all times. In order to meet any exceptional liquidity requirements, the Group maintains lines of credit with a number of financial institutions.

At the balance sheet date, the available liquidity is summarized as follows:

(CHF million)	31.12.2014	31.12.2013
Cash and cash equivalents	1 202	908
Marketable securities and derivative financial instruments	263	325
Short-term accessible liquidity reserves	1 465	1 233
Committed credit facilities	539	519
./ Utilized credit facilities	- 40	- 47
Total short-term accessible liquidity reserves and undrawn credit facilities	1 964	1 705

b. Capital management

The primary objective of the Group with regard to capital management is to preserve a strong equity base in order to maintain investor, creditor and market confidence and to sustain future development of the business. As at 31 December 2014, equity represented 83.7% (31 December 2013: 82.3%) of total assets.

The Group's Top Management reviews the capital structure of the Group and the equity of its subsidiaries on a regular basis. To preserve or adjust the capital structure, the Group may adjust the dividend payment to shareholders, return capital to shareholders, issue new debt or redeem existing debt. There were no changes in the Group's approach to capital management during the year.

NOTES TO THE CONSOLIDATED FINANCIAL STATEMENTS

4. Segment information

a. Operating segment information

Operating segments are reported consistent with the internal reporting provided to the Management Board. Although the Group's operations are worldwide, the main entrepreneurial focus remains on the product portfolio. This is reflected by the Group's divisional management and organizational structure and the Group's internal financial reporting systems.

The Group's activities are organized into numerous individual business units (Profit Centers) which are aggregated in the following reportable operating segments:

– Watches & Jewelry	Production and sale of watches and jewelry
– Electronic Systems	Design, production and commercialization of electronic components, Sports timing activities

The reportable operating segments generate their revenue mainly from the manufacture and sale of products to third parties or to other Group segments.

Corporate services does not qualify as a segment but is shown separately. It includes the activities of the Group's holding, finance, research and development, real estate and several other companies. Elimination of inter-segment sales, income and expense as well as assets and liabilities is shown in the column "Elimination".

Internal Group sales are recognized at arm's length. Segment expenses are those that can be directly attributed to the segment. Centralized costs relating to Group Management, Corporate Communication, Group Human Resources, Corporate Finance, Treasury, Tax and Legal Services are not reallocated to the operating segments and remain under the heading "Corporate".

Income statement

2014 (CHF million)	Watches & Jewelry	Electronic Systems	Corporate	Elimination	Total
– Third parties	8 935	277	7		9 219
– Group	1	22	6	– 29	–
Gross sales	8 936	299	13	– 29	9 219
– Third parties	8 428	274	7		8 709
– Group	1	22	6	– 29	–
Net sales	8 429	296	13	– 29	8 709
Operating result	1 860	– 9	– 99	–	1 752
– As a % of net sales	22.1	– 3.0			20.1
– As a % of total	106.2	– 0.5	– 5.7		100.0

2013 (CHF million)	Watches & Jewelry	Electronic Systems	Corporate	Elimination	Total
– Third parties	8 531	279	7		8 817
– Group	1	20	6	– 27	–
Gross sales	8 532	299	13	– 27	8 817
– Third parties	8 172	277	7		8 456
– Group	1	20	6	– 27	–
Net sales	8 173	297	13	– 27	8 456
Operating result	2 424	– 12	– 98	–	2 314
– As a % of net sales	29.7	– 4.0			27.4
– As a % of total	104.8	– 0.5	– 4.3		100.0

NOTES TO THE CONSOLIDATED FINANCIAL STATEMENTS

Balance sheet and other information

2014 (CHF million)	Watches & Jewelry	Electronic Systems	Corporate	Elimination	Total
Balance sheet					
– Segment assets	11 440	397	4 225	– 3 385	12 677
– Investments in associated companies and joint ventures	6	–	64		70
Total assets	11 446	397	4 289	– 3 385	12 747
Total liabilities	– 4 472	– 91	– 895	3 385	– 2 073
Net assets	6 974	306	3 394	–	10 674

Other information

Investments in property, plant and equipment	607	13	431		1 051
Investments in intangible assets	44	5	2		51
Investments in other non-current assets	115	0	0		115
Depreciation on property, plant and equipment	– 288	– 25	– 11		– 324
Amortization on intangible assets	– 29	– 2	– 3		– 34
Impairment charges	–	–	–		–

2013 (CHF million)	Watches & Jewelry	Electronic Systems	Corporate	Elimination	Total
Balance sheet					
– Segment assets	10 239	453	3 768	– 2 886	11 574
– Investments in associated companies and joint ventures	5	–	60		65
Total assets	10 244	453	3 828	– 2 886	11 639
Total liabilities	– 3 925	– 118	– 908	2 886	– 2 065
Net assets	6 319	335	2 920	–	9 574

Other information

Investments in property, plant and equipment	559	8	15		582
Investments in intangible assets	44	1	3		48
Investments in other non-current assets	84	0	0		84
Depreciation on property, plant and equipment	– 238	– 27	– 11		– 276
Amortization on intangible assets	– 23	– 2	– 3		– 28
Impairment charges	0	0	–		0

NOTES TO THE CONSOLIDATED FINANCIAL STATEMENTS

b. Information on geographical regions

(CHF million)	2014		2013	
	Net sales	Non-current assets	Net sales	Non-current assets
Switzerland	971	2 473	1 064	1 837
Other Europe	1 820	342	1 809	254
Total Europe	2 791	2 815	2 873	2 091
Greater China	3 224	248	3 208	215
Other Asia	1 814	237	1 527	222
Total Asia	5 038	485	4 735	437
Total America	737	122	709	92
Total Oceania	85	3	81	3
Total Africa	58	1	58	1
Total	8 709	3 426	8 456	2 624

For the geographical presentation, sales are reported according to the destinations that appear on the invoices. Non-current assets presented in the geographical information are broken down by location.

NOTES TO THE CONSOLIDATED FINANCIAL STATEMENTS

5. Revenues and expenses

a. Analysis of sales revenue	(CHF million)	2014	2013
	Sale of goods	8 680	8 424
	Rendering of services	29	32
	Total net sales	8 709	8 456

b. Other operating income In 2014, other operating income amounted to CHF 231 million and was mainly related to timekeeping services for the Olympic Games. In 2013, other operating income amounted to CHF 518 million and was mainly related to compensation from the successful outcome of the legal case against Tiffany & Co. USA.

c. Personnel expense	(CHF million)	2014	2013
	Wages and salaries	1 902	1 747
	Social security costs	316	292
	Share-based compensation (Note 29)	21	19
	Pension costs (Note 24)	104	86
	Total personnel expense	2 343	2 144

The development of the headcount is summarized in the following table:

(Unaudited)	2014	2013
Average annual headcount	34 492	31 114
Total headcount at 31 December	35 623	33 590
Men	17 035	15 986
Women	18 588	17 604
Swiss contracts	17 408	16 704
Non-Swiss contracts	18 215	16 886

Headcount is expressed as the number of employment contracts. The number of employees includes home workers, trainees and auxiliary staff.

d. Other operating expenses	(CHF million)	2014	2013
	Marketing, sales and administration	1 347	1 261
	Subcontracting and other direct costs of sales	304	313
	Maintenance, rents and energy	843	703
	Other operating expenses	150	65
	Total other operating expenses	2 644	2 342

e. Research and development costs Research and development (R&D) costs amounted to CHF 187 million in 2014, representing 2.1% of net sales (previous year: CHF 184 million or 2.2%).

f. Net financial result	(CHF million)	2014	2013
	Interest income	7	28
	Result from marketable securities at fair value	12	29
	Net currency result	-2	-27
	Other financial expense	-4	-5
	Other financial income and expense	13	25
	Interest expense	-2	-2
	Share of result from associates and joint ventures	3	13
	Net financial result	14	36

g. Non-operating result Only net income from investment property is included in the non-operating result position.

NOTES TO THE CONSOLIDATED FINANCIAL STATEMENTS

6. Income taxes

a. Income tax expenses	(CHF million)	2014	2013
Current income taxes		344	403
Adjustments recognized for current income taxes of prior periods		-1	10
Deferred taxes		6	15
Total income taxes		349	428

b. Reconciliation of the Group's effective tax rate

Since the Group operates worldwide, it is subject to income taxes in many different tax jurisdictions. The Group calculates its average expected tax rate as a weighted average of tax rates in the relevant tax jurisdictions.

	2014	2013
	%	%
Group's average expected tax rate	19.1	17.3
Tax effect of:		
- Change in the applicable tax rate on temporary differences	-0.7	-0.2
- Recognition of unused tax losses from prior years	-0.1	-0.6
- Utilization of previously unrecognized tax losses	0.0	-0.3
- Unrecognized current year tax losses	0.4	1.0
- Non-taxable income	-0.2	-0.1
- Non-tax-deductible expenses	0.7	0.6
- Items taxable at reduced rates	-0.3	-0.3
- Adjustments recognized for current taxes of prior periods	0.0	0.4
- Other items	0.9	0.4
Group's effective tax rate	19.8	18.2

The effective tax rate based on the ordinary result in the year under review was 19.8% (previous year: 18.2%).

c. Current income tax

	(CHF million)	2014	2013
Net current income tax liability			
Balance at 1 January		-171	-150
Recognized in income statement		-343	-413
Recognized in equity		-	-
Income taxes paid		428	392
Translation differences		-3	0
Balance at 31 December		-89	-171
thereof current income tax assets		45	19
thereof current income tax liabilities		-134	-190

d. Deferred tax

Deferred tax assets and liabilities are offset within legal entities when there is a legally enforceable right to offset current tax assets against current tax liabilities and when the deferred taxes relate to the same taxation authority.

The deferred tax assets and liabilities relate to the following balance sheet items:

(CHF million)	31.12.2014			31.12.2013		
	Assets	Liabilities	Net amount	Assets	Liabilities	Net amount
Inventories	303	-414	-111	281	-427	-146
Trade and other receivables	2	-24	-22	4	-17	-13
Property, plant and equipment	16	-128	-112	17	-113	-96
Intangible assets	15	-9	6	8	-8	0
Provisions	14	-45	-31	10	-43	-33
Retirement benefit obligations	4	-2	2	5	0	5
Tax losses	36	-	36	57	-	57
Other	61	-63	-2	47	-60	-13
Total deferred tax assets (liabilities)	451	-685	-234	429	-668	-239
Deferred tax assets			370			337
Deferred tax liabilities			-604			-576

NOTES TO THE CONSOLIDATED FINANCIAL STATEMENTS

Deferred tax assets resulting from deductible temporary differences, tax credits or carryforward tax losses are recognized only to the extent that realization of the related tax benefit is probable.

The gross value of unused carryforward tax losses which have, or have not, been recognized as deferred tax assets, with their expiry dates is as follows:

(CHF million)	Not recognized	Recognized	Total 2014
One year	2	1	3
Two years	3	12	15
Three years	3	12	15
Four years	4	7	11
Five years	3	2	5
Six years	0	11	11
More than six years	129	82	211
Total at 31.12.2014	144	127	271

(CHF million)	Not recognized	Recognized	Total 2013
One year	2	3	5
Two years	6	3	9
Three years	5	12	17
Four years	4	12	16
Five years	12	7	19
Six years	16	1	17
More than six years	195	154	349
Total at 31.12.2013	240	192	432

The potential tax effect resulting from the utilization of previously unrecognized carryforward tax losses amounted to CHF 44 million in the year under review (previous year: CHF 65 million).

NOTES TO THE CONSOLIDATED FINANCIAL STATEMENTS

7. Earnings per share

a. Basic

	2014	2013
Net income attributable to equity holders of The Swatch Group Ltd (CHF million)	1 384	1 921
Percentage of registered shares outstanding in comparison with the share capital outstanding	44.2%	44.1%
Percentage of bearer shares outstanding in comparison with the share capital outstanding	55.8%	55.9%
Registered shares		
Net income attributable to registered shareholders (CHF million)	611	847
Average number of shares outstanding	119 894 096	119 514 584
Basic earnings per share (in CHF)	5.10	7.08
Bearer shares		
Net income attributable to bearer shareholders (CHF million)	773	1 074
Average number of shares outstanding	30 320 769	30 335 000
Basic earnings per share (in CHF)	25.49	35.41

b. Diluted

	2014	2013
Registered shares		
Net income attributable to registered shareholders (CHF million)	612	848
Average number of shares outstanding – basic (as above)	119 894 096	119 514 584
Potential number of shares from options outstanding	230 587	232 711
Average potential number of shares outstanding – diluted	120 124 683	119 747 295
Diluted earnings per share (in CHF)	5.09	7.08
Bearer shares		
Net income attributable to bearer shareholders (CHF million)	772	1 073
Average potential number of shares outstanding	30 320 769	30 335 000
Diluted earnings per share (in CHF)	25.47	35.38

8. Dividends paid and proposed

On 14 May 2014, the Annual General Meeting approved the distribution of a dividend of CHF 1.50 per registered share and CHF 7.50 per bearer share. The distribution to holders of outstanding shares totaled CHF 407 million (2013: CHF 366 million) and has been recorded against retained earnings in 2014.

At the Annual General Meeting on 28 May 2015, payment of the following dividends for 2014 will be proposed:

	Registered	Bearer
Dividend per share	CHF 1.50	CHF 7.50
Total dividend	CHF 186 067 500	CHF 231 300 000

The financial statements ending 31 December 2014 do not take into account this proposed dividend. Dividends will be treated as an appropriation of available earnings during the financial year 2015.

NOTES TO THE CONSOLIDATED FINANCIAL STATEMENTS

9. Cash and cash equivalents

(CHF million)	31.12.2014	31.12.2013
Current accounts and liquid assets	984	810
Short-term deposits with financial institutions	218	98
Total cash and cash equivalents	1 202	908

The average yield on short-term bank deposits corresponds to the average interest rate on an investment on the money markets with a term of up to three months.

For the purposes of the consolidated statement of cash flows, cash and cash equivalents include the following items:

(CHF million)	31.12.2014	31.12.2013
Cash and cash equivalents	1 202	908
Current account overdrafts (Note 20)	0	0
Total funds net cash	1 202	908

10. Marketable securities and derivative financial instruments

(CHF million)	31.12.2014	31.12.2013
Equity securities	49	55
Bond securities	195	238
Investment funds and other investments	19	32
Total marketable securities at fair value	263	325

Derivative financial instruments	0	0
---	----------	----------

Total marketable securities and derivative financial instruments	263	325
---	------------	------------

The table below gives an overview of the contract values and fair values of derivative financial instruments by type of contract.

Type (CHF million)	31.12.2014			31.12.2013		
	Contract value	Positive fair value	Negative fair value	Contract value	Positive fair value	Negative fair value
Forward contracts in						
CNY	50	–	–1	–	–	–
EUR	361	0	–1	405	–	–2
GBP	40	–	–1	26	–	–1
JPY	21	–	0	7	–	0
RUB	6	–	0	16	–	0
SGD	16	–	0	1	–	0
USD	949	–	–25	565	–	–4
Other currencies	31	0	–1	29	–	–1
Gold	–	–	–	69	–	0
Total	1 474	0	–29	1 118	–	–8

NOTES TO THE CONSOLIDATED FINANCIAL STATEMENTS

11. Trade receivables

(CHF million)	31.12.2014	31.12.2013
Trade receivables – gross	1 121	1 083
Allowance for impaired receivables	– 13	– 10
Total trade receivables – net	1 108	1 073

The evolution of the allowance for impaired receivables can be summarized as follows:

(CHF million)	2014	2013
Balance at 1 January	– 10	– 8
Translation differences	0	0
Business combinations	–	– 1
Utilization	1	0
Reversal	1	1
Creation	– 5	– 2
Balance at 31 December	– 13	– 10

The individually impaired receivables mainly relate to amounts overdue more than 12 months and to customers with solvency risks. Based on past experience with the quality of trade receivables, no material increase in credit losses is expected.

Net trade receivables are recognized in the following major currencies:

(CHF million)	31.12.2014	31.12.2013
CHF	208	209
CNY	294	301
EUR	182	185
HKD	57	54
JPY	30	27
USD	122	104
Other currencies	215	193
Total trade receivables – net	1 108	1 073

Invoices are essentially issued in the currency of the primary economic environment in which the entity operates.

12. Other current assets

(CHF million)	31.12.2014	31.12.2013
VAT to be refunded	104	126
Other receivables	31	130
Total other current assets	135	256

NOTES TO THE CONSOLIDATED FINANCIAL STATEMENTS

13. Inventories

(CHF million)	31.12.2014	31.12.2013
Raw materials	345	383
Work in progress	565	582
Semi-finished goods	2 069	1 933
Finished goods	2 659	2 246
Spare parts for customer service	305	282
Total inventories	5 943	5 426

Inventories with risk of obsolescence have been adjusted to their net realizable value. In 2014, the Group recognized write-downs of CHF 33 million (previous year: write-downs of CHF 105 million, mainly related to Tiffany products). In addition, an amount of CHF 10 million (previous year: CHF 7 million) was reversed. The net impact of these adjustments was a charge to the income statement of CHF 23 million (previous year: CHF 98 million).

14. Prepayments and accrued income

(CHF million)	31.12.2014	31.12.2013
Prepaid sales, marketing and administration costs	107	104
Income tax assets	45	19
Other prepayments and accrued income	143	562
Total prepayments and accrued income	295	685

At 31 December 2013 the position Other prepayments and accrued income was mainly comprised of a receivable related to the closed Tiffany & Co. USA case which was settled in January 2014.

NOTES TO THE CONSOLIDATED FINANCIAL STATEMENTS

15. Property, plant and equipment

(CHF million)	Land, buildings and properties ¹⁾	Technical equipment & machinery	Other equipment & fixtures	Advances and construction in progress	Total
Historical cost, 31 December 2013	1 453	3 218	435	134	5 240
Translation differences	-1	29	4	-	32
Acquisition of subsidiaries (Note 18)	1	-	0	-	1
Divestments of businesses (Note 18)	-	-10	-3	-	-13
Additions	558	390	64	39	1 051
Disposals	-3	-95	-29	0	-127
Transfers	65	-5	5	-65	-
Historical cost, 31 December 2014	2 073	3 527	476	108	6 184
Accumulated depreciation, 31 December 2013	- 600	- 2 129	- 239	-	- 2 968
Translation differences	-1	-17	-1	-	-19
Depreciation on divestments of businesses (Note 18)	-	9	3	-	12
Annual depreciation	-47	-227	-50	-	-324
Impairment	-	-	-	-	-
Depreciation on disposals	2	95	28	-	125
Transfers	-	2	-2	-	-
Accumulated depreciation, 31 December 2014	- 646	- 2 267	- 261	-	- 3 174
Net book values:					
Balance at 31 December 2013	853	1 089	196	134	2 272
Balance at 31 December 2014	1 427	1 260	215	108	3 010
Insured value					6 667
Net book value of property, plant and equipment under finance lease contracts					1
Total non-current assets pledged to guarantee the commitments of Group companies					40

¹⁾ The category Land, buildings and properties includes investment properties with a carrying amount of CHF 452 million (previous year: CHF 32 million). The increase compared to the previous year is mainly due to the acquisition of the Peterhof commercial building on the Bahnhofstrasse in Zurich.

(CHF million)	Land, buildings and properties ¹⁾	Technical equipment & machinery	Other equipment & fixtures	Advances and construction in progress	Total
Historical cost, 31 December 2012	1 292	2 958	435	111	4 796
Translation differences	-32	-9	-10	0	-51
Acquisition of subsidiaries (Note 18)	48	31	18	-	97
Additions	91	324	66	101	582
Disposals	-24	-97	-63	-	-184
Transfers	78	11	-11	-78	-
Historical cost, 31 December 2013	1 453	3 218	435	134	5 240
Accumulated depreciation, 31 December 2012	- 581	- 2 037	- 256	0	- 2 874
Translation differences	-1	11	8	0	18
Annual depreciation	-42	-195	-39	-	-276
Impairment	0	0	0	-	0
Depreciation on disposals	24	97	43	-	164
Transfers	0	-5	5	-	-
Accumulated depreciation, 31 December 2013	- 600	- 2 129	- 239	0	- 2 968
Net book values:					
Balance at 31 December 2012	711	921	179	111	1 922
Balance at 31 December 2013	853	1 089	196	134	2 272
Insured value					5 902
Net book value of property, plant and equipment under finance lease contracts					1
Total non-current assets pledged to guarantee the commitments of Group companies					46

NOTES TO THE CONSOLIDATED FINANCIAL STATEMENTS

16. Intangible assets

(CHF million)	Capitalized development costs	Software	Other intangible assets	Total
Historical cost, 31 December 2013	80	111	109	300
Translation differences	0	0	-1	-1
Acquisition of subsidiaries (Note 18)	-	-	-	-
Divestments of businesses (Note 18)	-4	0	-	-4
Additions	15	16	20	51
Disposals	-1	-5	-3	-9
Transfers	9	1	-10	0
Historical cost, 31 December 2014	99	123	115	337
Accumulated amortization, 31 December 2013	-46	-84	-34	-164
Translation differences	0	0	0	0
Depreciation on divestments of businesses (Note 18)	3	0	-	3
Annual depreciation	-15	-13	-6	-34
Impairment	-	-	-	-
Depreciation on disposals	0	5	3	8
Transfers	-	0	0	0
Accumulated amortization, 31 December 2014	-58	-92	-37	-187
Net book values:				
Balance at 31 December 2013	34	27	75	136
Balance at 31 December 2014	41	31	78	150

(CHF million)	Capitalized development costs	Software	Other intangible assets	Total
Historical cost, 31 December 2012	88	96	80	264
Translation differences	-	-1	1	0
Acquisition of subsidiaries (Note 18)	-	0	1	1
Additions	10	17	21	48
Disposals	0	-1	-12	-13
Transfers	-18	-	18	0
Historical cost, 31 December 2013	80	111	109	300
Accumulated amortization, 31 December 2012	-35	-73	-40	-148
Translation differences	-	0	-1	-1
Annual depreciation	-11	-12	-5	-28
Impairment	-	0	0	0
Depreciation on disposals	0	1	12	13
Transfers	0	-	0	0
Accumulated amortization, 31 December 2013	-46	-84	-34	-164
Net book values:				
Balance at 31 December 2012	53	23	40	116
Balance at 31 December 2013	34	27	75	136

NOTES TO THE CONSOLIDATED FINANCIAL STATEMENTS

17. Investments in associates and joint ventures

(CHF million)	2014	2013
Balance at 1 January	65	110
Share of result from associates and joint ventures	3	13
Dividends received	-3	-21
Investments	-	14
Reclassification of previously held interests	-	-52
Investments acquired through business combinations	-	3
Translation differences	5	-2
Balance at 31 December	70	65

All associates and joint ventures are recognized using the equity method. They have been listed in Note 32. Despite having less than 20% of the voting power of Hengdeli Holdings, the Swatch Group can exercise significant influence due to representation on the Board of Directors, access to current financial information and the strategic character of the investment. Therefore, this investment is defined as associate.

In 2014 there were no changes in investments in associates and joint ventures.

In 2013, the Group increased its stake in Belenos Clean Power Holding AG from 42% to 49%.

Additionally, on 24 November 2013, the Swatch Group increased its stake in Rivoli Investments LLC from 40% to 58%, effectively taking control of the company. As a result, Rivoli Investments LLC and its subsidiaries became fully consolidated entities of the Swatch Group. The share in Rivoli Investments LLC previously held was removed from investments in associates and included in the calculation of goodwill from this acquisition (see Note 18).

At 31 December 2014, the fair value of the investment in Hengdeli Holdings was CHF 81 million (2013: CHF 92 million). Sales to and purchases from associates and joint ventures amounted to CHF 1 044 million (2013: CHF 1 119 million) and CHF 12 million (2013: CHF 8 million) respectively.

At balance sheet date, associated companies and joint ventures had no contingent liabilities (2013: CHF 1 million).

18. Business combinations

a. Acquisition of subsidiaries

In the first half of 2014, the Swatch Group acquired all the shares of René Clémence S.A. in La Chaux-de-Fonds (Switzerland). The company is a watch glass manufacturer.

The Group also acquired 100% of the shares of the Canadian company H.W. Protection Inc, Toronto in the first half of 2014. This company provides services solely to other Group companies.

On 26 March 2013, the Swatch Group acquired 100% of the shares in the US company HW Holdings Inc., which owns Harry Winston Inc., New York. The Group took over all the company's activities in connection with high jewelry and watches, including its watch manufacturer in Geneva (Switzerland). This does not affect the operations of Dominion Diamond Corporation in Toronto (Canada). As a result of this acquisition, a total of ten companies were incorporated into the Swatch Group's consolidation structure.

Also, on 24 November 2013, Technocorp Holding AG, a subsidiary of the Swatch Group, increased its 40% share in Rivoli Investments LLC (Rivoli Group) to 58%, with the purchase of an additional equity stake. Rivoli Group operates an extensive network of retail stores in the Middle East which are primarily active in the watch sector and employed over 1 500 persons at the acquisition date. Until the purchase of the additional share package, Rivoli Group was treated as an associate of the Swatch Group. With the increase of its investment, Swatch Group took control of Rivoli Group (comprised of 18 companies and one joint venture). As a result, these companies became fully consolidated subsidiaries of the Swatch Group. The previously held share in Rivoli Group was removed from investments in associates (see Note 17) and included in the calculation of goodwill from this acquisition.

NOTES TO THE CONSOLIDATED FINANCIAL STATEMENTS

The following table summarizes the recognized amounts of assets acquired and liabilities assumed at the acquisition date, as well as the consideration paid and the goodwill arising on acquisitions:

(CHF million)	Notes	2014	2013	2013	2013
		Actual Values Total	Actual Values Harry Winston	Actual Values Rivoli	Actual Values Total
Cash and cash equivalents		1	27	27	54
Current assets		0	425	148	573
Property, plant and equipment	(15)	1	73	24	97
Intangible assets	(16)	–	1	0	1
Other non-current assets	(19)	–	9	6	15
Investments in associates and joint ventures	(17)	–	–	3	3
Deferred tax assets		0	14	2	16
Current liabilities		0	– 122	– 103	– 225
Deferred tax liabilities		–	– 10	–	– 10
Non-current liabilities		–	– 274	– 6	– 280
Provisions	(23)	0	– 1	–	– 1
Previously held interests	(17)	–	–	– 52	– 52
Non-controlling interests		–	–	– 46	– 46
Net assets acquired		2	142	3	145
Goodwill (recognized in equity)	(27)	3	569	99	668
Total purchase consideration (incl. acquisition-related costs)		5	711	102	813
Cash and cash equivalents acquired		– 1	– 27	– 27	– 54
Consideration payable		0	–	–	–
Cash outflow on acquisitions		4	684	75	759

Goodwill from the 2014 acquisitions relates primarily to the expected operating synergies from these combinations and the acquired know-how from the takeovers.

Goodwill from the acquisition of HW Holdings Inc. in 2013 was mainly attributed to the Harry Winston brand name, the acquired retail business and all activities related to the manufacture of high jewelry and watches. Goodwill from the takeover of Rivoli Investments LLC resulted from the superbly developed retail network and the related level of brand awareness of the Rivoli Group in the Middle East.

For all acquisitions in 2014 and 2013 the purchase consideration basically represented the cash payments made to the vendors. Transaction costs related to the takeovers were recognized as part of goodwill directly in equity.

b. Divestments of businesses

At the beginning of April 2014, Swatch Group sold its entire participation in Oscilloquartz AG, Neuenburg (Switzerland), to ADVA Optical Networking SE, Munich (Germany).

The value of the net assets disposed of and the cash inflow from the disposal are as follows:

(CHF million)	Notes	2014	2013
		Actual Values	Actual Values
Cash and cash equivalents		0	–
Current assets		14	–
Property, plant and equipment	(15)	1	–
Intangible assets	(16)	1	–
Current liabilities		– 4	–
Provisions	(23)	0	–
Net assets disposed of		12	–
Loss on divestment of businesses		– 9	–
Total disposal consideration		3	–
Cash and cash equivalents disposed of		0	–
Net Cash inflow on disposal		3	–

No companies were disposed of in 2013.

NOTES TO THE CONSOLIDATED FINANCIAL STATEMENTS

19. Other non-current assets

(CHF million)	Prepaid marketing and rental cost	Security deposits	Other financial assets	Total
Balance at 31 December 2013	74	71	11	156
Translation differences	2	5	0	7
Acquisition of subsidiaries (Note 18)	–	–	–	–
Additions	94	21	0	115
Disposals	– 1	– 2	–	– 3
Transfers to current assets	– 74	–	–	– 74
Balance at 31 December 2014	95	95	11	201

(CHF million)	Prepaid marketing and rental cost	Security deposits	Other financial assets	Total
Balance at 31 December 2012	22	45	110	177
Transfers from Prepayments at 1 January	51	–	–	51
Translation differences	– 1	– 4	– 2	– 7
Acquisition of subsidiaries (Note 18)	–	15	–	15
Additions	67	16	1	84
Disposals	0	– 1	– 8	– 9
Transfers to current assets	– 65	–	– 90	– 155
Balance at 31 December 2013	74	71	11	156

Key money that the Group pays when renting stores in strategic locations is recognized as prepaid rent when recovery at the end of the contract is not certain. The non-current portion of key money, together with the non-current prepaid marketing costs, is recognized under Other non-current assets. The current portion of both components is transferred to Prepayments and accrued income.

NOTES TO THE CONSOLIDATED FINANCIAL STATEMENTS

20. Financial debts and derivative financial instruments

(CHF million)	31.12.2014	31.12.2013
Current account overdrafts	0	0
Short-term leasing commitments	1	1
Short-term bank debt	5	6
Derivative financial instruments	29	8
Total current financial debts and derivative financial instruments	35	15
Total non-current financial debts	38	44
Total financial debts	73	59

The exposure of the Group's financial debts to interest rate changes is limited as most of these debts have fixed interest rates. The contractual repricing dates at the balance sheet date are as follows:

(CHF million)	less than 1 year	1–5 years	over 5 years	Total
At 31 December 2014	35	17	21	73
At 31 December 2013	15	22	22	59

The carrying amounts of the Swatch Group's financial debts are denominated in the following currencies:

(CHF million)	31.12.2014	31.12.2013
CHF	29	10
JPY	39	45
EUR	1	1
Other currencies	4	3
Total	73	59

The Swatch Group had no listed debenture bonds or convertible bonds outstanding in the years under review. The long-term financial debts at the end of 2014 included a mortgage of JPY 4 250 million or CHF 35 million (previous year: JPY 4 750 million or CHF 40 million) at a fixed interest rate of 2.41% with a term until March 2021 (without a termination clause).

21. Other liabilities

(CHF million)	31.12.2014	31.12.2013
Advance payments	36	31
Income tax liabilities	16	21
VAT due	11	4
Other payables	95	108
Total other payables	158	164

NOTES TO THE CONSOLIDATED FINANCIAL STATEMENTS

22. Accrued expenses

(CHF million)	31.12.2014	31.12.2013
Accrued salaries and social security	177	168
Accrued sales, marketing and administration costs	162	162
Accrued income taxes	118	169
Accrued sales reductions	84	74
Other accrued expenses	158	158
Total accrued expenses	699	731
thereof current	661	702
thereof non-current	38	29

23. Provisions

(CHF million)	Warranties	Litigation	Other	Total
Balance at 31 December 2012	78	6	21	105
Translation differences	-2	0	0	-2
Acquisition of subsidiaries (Note 18)	0	-	1	1
Additional provisions	80	2	14	96
Reversal of provisions	-12	0	-2	-14
Provisions used during the year	-57	-2	-8	-67
Balance at 31 December 2013	87	6	26	119
thereof current provisions	60	3	11	74
thereof non-current provisions	27	3	15	45
Translation differences	3	0	0	3
Acquisition of subsidiaries (Note 18)	0	0	0	0
Divestments of businesses (Note 18)	0	0	0	0
Additional provisions	97	3	3	103
Reversal of provisions	-7	-2	-1	-10
Provisions used during the year	-76	-1	-8	-85
Balance at 31 December 2014	104	6	20	130
thereof current provisions	72	2	9	83
thereof non-current provisions	32	4	11	47

a. Warranty

In the majority of cases, the Group offers a two-year warranty covering the repairs or replacement of products that do not perform to customers' satisfaction. The provision made at year-end to cover anticipated warranty costs is based on past experience with respect to the volume of repairs and returns.

b. Legal risks

Some Group companies are involved in litigation arising from the ordinary course of their business. Management estimated the outcome of these lawsuits on the basis of currently available information and recorded adequate provisions. However, there are inherent risks within legal claims depending on court and adversary party behaviour and opinion that may cause a significant outflow of economic benefits.

c. Other

Other provisions relate to various present legal or constructive obligations of the Group companies toward third parties.

NOTES TO THE CONSOLIDATED FINANCIAL STATEMENTS

24. Retirement benefit obligations

Employer contributions reserve (ECR) / shares held by pension institutions

The Group has an employer contribution reserve in the Swiss pension fund of the Swatch Group, which amounts to CHF 5 million. This reserve is capitalized in other non-current assets. The ECR remained unchanged in the year under review; there has been no formation or dissolution, nor has there been a waiver of usage.

Pension fund assets included 5 384 595 registered shares (2013: 5 539 307 shares) and 1 100 bearer shares (2013: 120 shares) of The Swatch Group Ltd.

Economic benefit / economic obligation and pension benefit expenses

2014

(CHF million)	Surplus / deficit	Group's economic share	Change from previous year and/or income statement impact in current year	Contributions concerning the business period	Pension costs within personnel expense
Patronage funds / patronage pension plans	320	–	–	–	–
Pension plans without surplus / deficit	–	–	–	98	98
Pension plans with surplus	–	–	–	–	–
Pension plans with deficit	–11	–6	1	1	2
Pension plans without own assets	–	–32	4	–	4
Total	309	–38	5	99	104

2013

(CHF million)	Surplus / deficit	Group's economic share	Change from previous year and/or income statement impact in current year ¹⁾	Contributions concerning the business period	Pension cost within personnel expense
Patronage funds / patronage pension plans	301	–	–	–	–
Pension plans without surplus / deficit	–	–	0	84	84
Pension plans with surplus	–	–	–	–	–
Pension plans with deficit	–18	–9	0	1	1
Pension plans without own assets	–	–24	10	1	1
Total	283	–33	10	86	86

¹⁾The change in the Group's economic share was attributed to business combinations and reclassifications within the balance sheet and had no impact on the income statement.

Summary of pension benefit expenses

(CHF million)	Switzerland 2014	Abroad 2014	Total 2014	Switzerland 2013	Abroad 2013	Total 2013
Contributions to pension plans charged to Group companies	86	13	99	76	10	86
Contributions to pension plans paid from ECR	–	–	–	–	–	–
Total contributions	86	13	99	76	10	86
Change of ECR from evolution of fortune, impairments, discounting, etc.	0	–	0	0	–	0
Contributions and change in ECR	86	13	99	76	10	86
Increase / decrease of Groups's economic benefits from surpluses	–	–	–	–	–	–
Decrease / increase of economic obligations from deficits	–	5	5	–	0	0
Total changes of economic effects from surpluses / deficits	–	5	5	–	0	0
Pension benefit expenses within personnel expenses of the period	86	18	104	76	10	86

NOTES TO THE CONSOLIDATED FINANCIAL STATEMENTS

25. Commitments and contingencies

a. Guarantees and sureties

At 31 December 2014, guarantees to third parties as security for commitments of Group companies amounted to CHF 8 million (2013: CHF 5 million).

Total current assets pledged by Group companies to guarantee their commitments amounted to CHF 95 million at 31 December 2014 (2013: CHF 71 million).

b. Leasing and other commitments

The Group's fixed operating leasing commitments that cannot be cancelled within 12 months and which are not recognized in the balance sheet are due as follows:

(CHF million)	31.12.2014	31.12.2013
Less than 1 year	385	334
Between 1 and 5 years	959	753
Over 5 years	510	427
Total	1 854	1 514

The figures in the preceding table include all rental contracts for buildings, a major part of which relate to the Group's retail business, and to all other standard rental contracts existing at 31 December 2014. Leasing costs amounting to CHF 511 million were recognized in the 2014 income statement, compared to CHF 384 million in the previous year.

Other commitments relating mainly to investments in tangible fixed assets entered into by the Group, and ongoing at 31 December 2014, amounted to CHF 76 million (CHF 156 million in the previous year).

c. Contingent assets and liabilities

Some Group companies have contingent liabilities in respect of legal claims arising from the ordinary course of business and they may be liable to pay compensation. It is not expected that any material liabilities will arise from these contingent liabilities other than those provided for (see Note 23b).

In some cases the Group is defending its rights where there is also an inherent possibility of inflows of economic benefits if the cases are successful.

NOTES TO THE CONSOLIDATED FINANCIAL STATEMENTS

26. Share capital and reserves**a. Share capital**

Over the past three years, the share capital of The Swatch Group Ltd has developed as follows:

Balance sheet date	Registered shares	Bearer shares	Share capital in CHF
31.12.2012	124 045 000 at CHF 0.45	30 840 000 at CHF 2.25	125 210 250.00
31.12.2013	124 045 000 at CHF 0.45	30 840 000 at CHF 2.25	125 210 250.00
31.12.2014	124 045 000 at CHF 0.45	30 840 000 at CHF 2.25	125 210 250.00

At year-end 2014 as well as 2013, there was no authorized or conditional capital. All issued shares are fully paid. No benefit certificates exist. In accordance with the articles of incorporation of the Swatch Group, the Board of Directors shall refuse a registered share ownership of more than 5% per shareholder. In exceptional cases, the Board of Directors may consent to an exception to this rule.

b. Capital reserves

Capital reserves include proceeds from the sale of treasury shares and the effects of capital reductions in prior years. In addition, capital reserves include non-distributable, statutory or legal reserves amounting to CHF 82 million (2013: CHF 57 million). These reserves come from the holding company The Swatch Group Ltd.

c. Treasury shares

Changes in shares of The Swatch Group Ltd held by the Group (treasury shares) are presented in the following table:

	Registered shares		Bearer shares		Total
	Quantity	Value	Quantity	Value	
		CHF million		CHF million	CHF million
Balance at 31 December 2012	5 677 177	211	505 000	132	343
Acquisitions ¹⁾	17 800	2	–	–	2
Disposals ²⁾	– 1 568 681	– 77	–	–	– 77
Balance at 31 December 2013	4 126 296	136	505 000	132	268
Acquisitions ¹⁾	385 000	33	164 000	74	107
Disposals ²⁾	– 252 308	– 1	– 164 000	– 73	– 74
Balance at 31 December 2014	4 258 988	168	505 000	133	301

¹⁾ In 2014, the Group acquired 385 000 (2013: 17 800) registered shares at an average price of CHF 86.28 (2013: CHF 91.43) each. The Group also acquired 164 000 bearer shares at an average price of CHF 448.63 each (2013: no bearer shares purchased).

²⁾ In 2014, the Group sold 10 000 (2013: 1 323 718) registered shares at an average price of CHF 87.95 (2013: CHF 92.22) each. The remaining disposals of registered shares relate to the employee stock option plan. Details of the share options granted in connection with the employee stock option plan are provided in Note 29. The Group also sold 164 000 bearer shares at an average price of CHF 466.11 each (2013: no bearer shares sold).

Treasury shares are recognized in the consolidated financial statements at their historical cost. The value of these shares is charged against consolidated equity.

NOTES TO THE CONSOLIDATED FINANCIAL STATEMENTS

27. Acquired goodwill

a. Theoretical statement of changes in goodwill

Goodwill is recognized directly in equity at the time of purchase of a subsidiary or an investment in an associated company. The theoretical capitalization of goodwill, based on a useful life of 5 to 10 years, would have the following impact on equity and net income:

	2014			2013		
	Goodwill Group companies	Goodwill associated companies	Total	Goodwill Group companies	Goodwill associated companies	Total
(CHF million)						
Historical cost 1 January	1 386	48	1 434	545	221	766
Additions	3	–	3	668	–	668
Disposals	–	–	–	–	–	–
Transfers	–	–	–	173	–173	–
Historical cost 31 December	1 389	48	1 437	1 386	48	1 434
Theoretical accumulated amortization						
1 January	– 415	– 23	– 438	– 289	– 52	– 341
Theoretical annual amortization	– 117	– 5	– 122	– 77	– 20	– 97
Theoretical impairment	–	–	–	–	–	–
Theoretical amortization on disposals	–	–	–	–	–	–
Transfers	–	–	–	– 49	49	–
Theoretical accumulated amortization 31 December	– 532	– 28	– 560	– 415	– 23	– 438
Theoretical net book value 31 December	857	20	877	971	25	996

Acquisitions were translated into CHF with the exchange rate applicable on their respective transaction dates. As a result of this procedure, no currency adjustments were necessary in the statement of changes in goodwill.

Had goodwill been capitalized and amortized, the theoretical effect on equity and net income would have been as follows:

b. Theoretical impact on equity

	2014	2013
(CHF million)		
Equity, per balance sheet	10 674	9 574
Theoretical capitalization of net book value of goodwill	877	996
Theoretical equity including net book value of goodwill	11 551	10 570

c. Theoretical impact on net income

	2014	2013
(CHF million)		
Net income, per income statement	1 416	1 928
Theoretical amortization of goodwill	– 122	– 97
Theoretical net income after goodwill amortization	1 294	1 831

NOTES TO THE CONSOLIDATED FINANCIAL STATEMENTS

28. Details to the consolidated statement of cash flows

a. Non-cash items

(CHF million)	Notes	2014	2013
Reversal of non-cash items			
Share of result from associates and joint ventures	(17)	- 3	- 13
Income taxes	(6a)	349	428
Depreciation of property, plant and equipment	(15)	324	276
Amortization of intangible assets	(16)	34	28
Profit on sale of fixed assets		- 3	- 9
Loss on sale of fixed assets		3	2
Fair value gains on marketable securities		- 17	- 29
Fair value losses on marketable securities		25	18
Interest income	(5f)	- 7	- 28
Interest expense	(5f)	2	2
Expenses for equity-settled compensation plan	(29)	21	19
Changes in provisions		8	14
Changes in retirement benefit obligations		3	4
Total		739	712

b. Changes in working capital

(CHF million)	2014	2013
Changes in working capital and other items included in cash flow from operating activities		
Inventories	- 410	- 597
Trade receivables	- 2	18
Other receivables and accrued income	602	- 396
Trade payables	- 31	- 18
Other liabilities and accrued expenses	- 3	- 5
Other items included in cash flow from operating activities	- 64	33
Total	92	- 965

29. Employee stock option plan

When the Hayek Pool acquired control of the Swatch Group, a block of shares was reserved in 1986 for an equity-settled management stock option plan.

Under the terms of this plan, share options are granted to managers and employees who distinguished themselves by a particular strong commitment to the company or an above-average performance. One-third of the options granted can be exercised immediately, one-third after 12 months, and the remaining third after 24 months (European style). Options are conditional on the employee completing the service until the respective date of exercise. Options are not transferable and only exercisable by the employee. The Group has no legal or constructive obligation to repurchase or settle the options in cash. A tranche of treasury shares has been specifically reserved for this stock option plan. No new shares were issued under this plan. Group equity increases from the time the options are granted over the corresponding period by the value of the employee services (net of tax). When the options are exercised, Group equity increases further by the corresponding exercise price.

At the end of 2014, this portfolio comprised 1 154 463 registered shares (1 396 771 at the end of 2013). In 2014, 242 308 registered shares were exercised at a preferential price of CHF 4.00 per registered share.

Movements in the number of share options outstanding were as follows:

	2014	2013
	Options	Options
Options outstanding at 1 January	242 915	245 246
Granted	240 805	244 095
Forfeited or lapsed	- 604	- 1 463
Exercised	- 242 308	- 244 963
Options outstanding at 31 December	240 808	242 915

All options included in the table above have an exercise price of CHF 4.00.

NOTES TO THE CONSOLIDATED FINANCIAL STATEMENTS

Share options outstanding at the end of the year have the following expiry date:

Expiry date	Share options	
	31.12.2014	31.12.2013
2014		161 496
2015	160 477	81 419
2016	80 331	
Total	240 808	242 915

The fair value of the options granted during the period was determined by using the actual value at the grant date. The following table shows the assumptions on which the valuation of share options granted in 2014 and 2013 was based:

	2014		2013	
	Portion exercisable in 1 year	Portion exercisable in 2 years	Portion exercisable in 1 year	Portion exercisable in 2 years
Grant date	8 July 2014	8 July 2014	12 July 2013	12 July 2013
Expiration date	8 July 2015	8 July 2016	12 July 2014	12 July 2015
Closing share price on grant date	CHF 95.40	CHF 95.40	CHF 94.80	CHF 94.80
Exercise price	CHF 4.00	CHF 4.00	CHF 4.00	CHF 4.00
Market value of option at grant date	CHF 91.40	CHF 91.40	CHF 90.80	CHF 90.80

The first portion that was immediately exercisable was subject to the exercise conditions listed above.

The personnel expense recorded in the 2014 income statement amounted to CHF 21 million (2013: CHF 19 million).

30. Related party transactions

a. Principal shareholders

On 31 December 2014, the Hayek Pool and its related companies, institutions and individuals held 63 169 930 registered shares and 1 650 bearer shares, equivalent to 40.8% of the shares issued (previous year: 40.8%) of The Swatch Group Ltd, which is the parent company of the Group.

In the context of the pool, the group of the community of heirs of N. G. Hayek and related parties controlled in total 40.3% of the shares issued (previous year: 40.4%).

Mrs. Esther Grether's group controlled 5.9% of the shares issued (previous year: 7.1%).

In 2014, the Hayek Group, owned by the community of heirs of N. G. Hayek, invoiced an amount of CHF 9.6 million to the Swatch Group (previous year: CHF 10.2 million). This amount primarily covered support for Group Management in the following areas of activity:

(CHF million)	2014	2013
Audit, feasibility studies and process optimization	2.0	1.0
Executive functions	0.7	1.0
Project management in the construction sector	4.9	6.0
Support for projects in the materials and surface treatment technology sector	0.3	0.2
Leasing a store in the center of Cannes (France) in a building of a subsidiary of the Hayek Group	0.4	0.4
Various services relating to the assessment of investment projects, cost control, IT consulting, etc.	1.3	1.6
Total	9.6	10.2

NOTES TO THE CONSOLIDATED FINANCIAL STATEMENTS

b. Key management personnel

In addition to the members of the Board of Directors, the members of the Group Management Board and of the Extended Management Board are considered as key management personnel.

The total compensation of key management personnel, including pension contributions, other social benefits and share-based compensation, was as follows:

(CHF million)	2014	2013
Short-term employee benefits	27.7	28.8
– of which in salaries	9.0	9.1
– of which in bonus	18.1	19.0
– of which in expense allowances ¹⁾	0.5	0.6
– of which in other benefits	0.1	0.1
Share-based compensation	15.5	15.6
Contributions to pension plans	0.7	0.7
Other social benefits ²⁾	3.9	3.9
Total	47.8	49.0

¹⁾ In connection with the preparation of the compensation report, expense allowances specifically were integrated into the presentation of Key Management compensation retrospectively as of 2013.

²⁾ In connection with the preparation of the compensation report, other social benefits (employer's share) specifically were integrated into the presentation of Key Management compensation retrospectively as of 2013.

In the year under review, no termination benefits were paid to members of the Board of Directors, the Management Board or the Extended Management Board (previous year: none). The employment contracts of members of management bodies do not provide for this type of benefit. Also, no remuneration was paid to former members of management bodies for their previous functions.

c. Share ownership

At 31 December 2014, the executive members of the Board of Directors and the members of the Management Board of the company as well as the persons close to them held directly or indirectly a total of 56 571 025 registered shares and 790 bearer shares, representing 36.5% of the voting rights (previous year: 36.5%).

In addition, at 31 December 2014, all the non-executive members of the Board of Directors as well as the persons close to them held 2 010 bearer shares, representing 0.0% of the voting rights (previous year: 7.1%).

d. Loans to members of the governing bodies

The employees of the company may take out a mortgage loan with the Swatch Group Swiss Pension Fund for the construction or acquisition of property in Switzerland (primary residence). The conditions for these mortgage loans are set by the Swatch Group Swiss Pension Fund Foundation Board. These conditions are applied in the same manner to all employees.

In 2014 and 2013, no loans were granted to current or former members of the Board of Directors, the Management Board or the Extended Management Board. Also, at the end of both 2014 and 2013, no such loans were outstanding.

e. Associated companies and other related parties

The Group has transactions with associates, joint ventures and other related parties. A listing of the associated companies and joint ventures is included in the list of the Swatch Group companies (Note 32).

(CHF million)	2014		2013	
	Purchases	Sales	Purchases	Sales
Associates and joint ventures	12	1 044	8	1 119
Other related parties	0	0	0	0

At the end of 2014, receivables from associates amounted to CHF 254 million (2013: CHF 244 million), and payables to associates were less than CHF 1 million (2013: CHF 1 million). In addition, at the end of 2014 the Group held guarantees from associated companies in the amount of CHF 280 million (2013: CHF 243 million). At the end of 2014, the Group had granted no loans to associated companies (2013: none).

At the end of 2014 and 2013 there were no balances outstanding with other related parties.

31. Events after the balance sheet date

There were no significant events after the balance sheet date.

NOTES TO THE CONSOLIDATED FINANCIAL STATEMENTS

32. The Swatch Group Companies – as at 31.12.2014

Company name, Registered offices	Field of Activity	Capital in millions	Swatch Group Shareholdings %	Consoli- dation	Segment
Europe					
Switzerland					
The Swatch Group SA, Neuchâtel	Holding	CHF 125.21			▼
Assemti SA, Locarno	Assembly	CHF 0.10	100	●	▲
Asulab SA, La Tène	Research and development	CHF 0.10	100	●	▼
Belenos Clean Power Holding SA, Bienne	Holding	CHF 63.00	49	○	▼
Blancpain SA, Le Chenit	Watches	CHF 0.10	100	●	▲
Blancpain Les Boutiques SA, Le Chenit	Retail	CHF 0.10	100	●	▲
Breguet Les Boutiques SA, L'Abbaye	Retail	CHF 0.50	100	●	▲
Certina AG, Le Locle	Watches	CHF 3.50	100	●	▲
Cité du Temps SA, Genève	Communication	CHF 6.00	100	●	▼
cK Watch & Jewelry Co., Ltd., Bienne	Watches	CHF 5.00	90	●	▲
Comadur SA, Le Locle	Products in hard materials	CHF 7.86	100	●	▲
Compagnie des Montres Longines, Francillon SA, Saint-Imier	Watches	CHF 10.00	100	●	▲
Danyack SA, La Chaux-de-Fonds	Real estate	CHF 0.06	29	○	▼
Dernier Batz SA, Neuchâtel	Real estate	CHF 10.00	100	●	▼
Diantus Watch SA, Mendrisio	Watches, movements	CHF 10.00	100	●	▲
Distico SA, Torricella-Taverne	Distribution	CHF 3.00	100	●	▲
Dress your body SA, Corcelles-Cormondrèche	Jewelry	CHF 0.10	100	●	▲
EM Microelectronic-Marin SA, La Tène	Microelectronics	CHF 25.00	100	●	▶
Evaco SA, Möhlin	Watches	CHF 0.50	58	●	▲
ETA SA Manufacture Horlogère Suisse, Grenchen	Watches, movements and components	CHF 6.20	100	●	▶
François Golay SA, Le Chenit	Watch components	CHF 0.10	100	●	▲
Hamilton International AG, Bienne	Watches	CHF 3.00	100	●	▲
Harry Winston SA, Plan-les-Ouates	Watches	CHF 0.40	100	●	▲
ICB Ingénieurs Conseils en Brevets SA, Neuchâtel	Patents	CHF 0.20	100	●	▼
Maeder-Leschot SA, Bienne	Real estate	CHF 0.70	100	●	▼
Manufacture Ruedin SA, Haute-Sorne	Watch cases	CHF 2.40	100	●	▲
Mecco SA, Grenchen	Watch crowns	CHF 4.50	100	●	▲
Micro Crystal AG, Grenchen	Miniature low-frequency quartz crystals	CHF 4.00	100	●	▶
Mido AG, Le Locle	Watches	CHF 1.20	100	●	▲
MOM le Prélet SA, Val-de-Ruz	Watch dials	CHF 0.30	100	●	▲
Montres Breguet SA, L'Abbaye	Watches	CHF 10.00	100	●	▲
Montres Jaquet Droz SA, La Chaux-de-Fonds	Watches	CHF 12.00	100	●	▲
Nivarox-FAR SA, Le Locle	Watch components and thin wires	CHF 4.00	100	●	▲
Novi SA, Les Genevez	Assembly	CHF 0.14	100	●	▲
Omega Electronics AG, Bienne	Administration	CHF 1.50	100	●	▼
Omega SA, Bienne	Watches	CHF 50.00	100	●	▲
PHM Holding SA, Courtételle	Holding	CHF 0.10	100	●	▲
Rado Uhren AG, Lengnau	Watches	CHF 2.00	100	●	▲
Record Watch Co. SA, St-Imier	Administration	CHF 0.10	100	●	▼
Renata AG, Itingen	Miniature batteries	CHF 0.50	100	●	▶
René Clémence SA, La Chaux-de-Fonds	Watch-glasses	CHF 0.06	100	●	▲
Rubattel et Weyerermann SA, La Chaux-de-Fonds	Watch dials	CHF 0.15	100	●	▲
Simon et Membrez SA, Delémont	Watch cases	CHF 0.10	100	●	▲
S.I. Grand-Cernil 2, Les Brenets, SA, Les Brenets	Real estate	CHF 0.12	100	●	▼
S.I. Grand-Cernil 3, Les Brenets, SA, Les Brenets	Real estate	CHF 0.12	100	●	▼
S.I. Les Corbes SA, Val-de-Ruz	Real estate	CHF 0.10	34	○	▼
S.I. L'Etang SA, Les Brenets, Les Brenets	Real estate	CHF 0.05	100	●	▼
S.I. Rue de la Gare 2, Les Brenets, SA, Les Brenets	Real estate	CHF 0.24	100	●	▼
SSIH Management Services AG, Bienne	Services	CHF 0.05	100	●	▼
Swatch AG, Bienne	Watches	CHF 2.00	100	●	▲
Swatch Retail AG, Bienne	Retail	CHF 2.00	100	●	▲
Swiss Timing AG, Corgémont	Sports timing technology & equipment	CHF 2.00	100	●	▶
Technocorp Holding SA, Le Locle	Holding	CHF 6.00	100	●	▼
Terminoites SA, Basse-Allaine	Watch case polishing	CHF 0.10	60	●	▲
The Swatch Group Assembly SA, Mendrisio	Assembly	CHF 6.00	100	●	▲
The Swatch Group Europa AG, Bienne	Distribution	CHF 29.65	100	●	▲
The Swatch Group Far East Distribution Ltd, Bienne	Distribution	CHF 0.10	100	●	▲
The Swatch Group Immeubles SA, Neuchâtel	Real estate project & property management	CHF 0.50	80	●	▼
The Swatch Group Lab AG, Zürich	Services	CHF 0.60	100	●	▼
The Swatch Group Les Boutiques SA, Le Grand-Saconnex	Retail	CHF 3.00	100	●	▲
The Swatch Group Management Services SA, Bienne	Services	CHF 0.05	100	●	▼
The Swatch Group Recherche et Développement SA, La Tène	Research and development	CHF 0.10	100	●	▼
The Swatch Group Services SA, Bienne	Logistics, distribution and services	CHF 1.00	100	●	▼
Time Flagship AG, Zürich	Retail	CHF 6.00	100	●	▲
Tissot SA, Le Locle	Watches	CHF 5.00	100	●	▲
Universo SA, La Chaux-de-Fonds	Watch hands	CHF 0.67	100	●	▲

NOTES TO THE CONSOLIDATED FINANCIAL STATEMENTS

32. The Swatch Group Companies – as at 31.12.2014

Company name, Registered offices	Field of Activity	Capital in millions	Swatch Group Shareholdings %	Consoli- dation	Segment
Germany					
Fördergesellschaft der Glashütter Uhrenindustrie mbH, Glashütte	Watches	EUR 0.03	100	●	◀
Glashütter Uhrenbetrieb GmbH, Glashütte	Watches	EUR 0.51	100	●	◀
ST Sportservice GmbH, Leipzig	Sports timing technology & equipment	EUR 3.47	100	●	▶
Swiss Prestige Uhren Handel GmbH, Eschborn	Retail	EUR 0.08	100	●	◀
The Swatch Group Customer Service (Europe) GmbH, Glashütte	Customer service	EUR 0.50	100	●	◀
The Swatch Group (Deutschland) GmbH, Eschborn	Distribution	EUR 1.28	100	●	◀
The Swatch Group (Deutschland) Les Boutiques GmbH, Eschborn	Retail	EUR 0.20	100	●	◀
Union Uhrenfabrik GmbH, Glashütte	Watches	EUR 0.10	100	●	◀
Austria					
The Swatch Group (Oesterreich) GmbH, Wien	Distribution	EUR 0.04	100	●	◀
Belgium					
The Swatch Group (Belgium) SA, Anderlecht	Distribution	EUR 1.75	100	●	◀
The Swatch Group Participation SA, Anderlecht	Holding	EUR 2.09	100	●	◀
Spain					
The Swatch Group (España) SA, Alcobendas	Distribution	EUR 0.45	100	●	◀
France					
Breguet, Paris	Administration	EUR 0.04	100	●	◀
Fabrique de Fournitures de Bonnétage FFB, Villers-le-Lac	Precision parts	EUR 4.56	100	●	◀
Frésard Composants, Charquemont	Precision parts	EUR 1.80	100	●	◀
Centre Européen de Service Horloger, Besançon	Customer service	EUR 0.70	100	●	◀
Harry Winston S.A.R.L., Paris	Retail	EUR 2.99	100	●	◀
Tech Airport Holding, Paris	Retail	EUR 31.20	100	●	◀
The Swatch Group (France) SAS, Paris	Distribution	EUR 15.00	100	●	◀
The Swatch Group (France) Les Boutiques, Paris	Retail	EUR 55.13	100	●	◀
Great Britain					
Harry Winston (UK) Ltd, London	Retail	GBP 0.00	100	●	◀
The Swatch Group (UK) Ltd, London	Distribution	GBP 2.00	100	●	◀
The Swatch Group (UK) Les Boutiques Ltd, London	Retail	GBP 1.30	100	●	◀
Greece					
Alkioni SA, Athens	Retail	EUR 0.10	100	●	◀
The Swatch Group (Greece) SA, Athens	Distribution	EUR 0.06	100	●	◀
Italy					
Lascor S.p.A., Sesto Calende	Watch cases and bracelets	EUR 1.00	100	●	◀
The Swatch Group Europe Services S.r.l., Milano	Administration	EUR 0.01	100	●	◀
The Swatch Group (Italia) S.p.A., Milano	Distribution	EUR 23.00	100	●	◀
Luxembourg					
The Swatch Group SICAF-SIF, Alzingen	Finance company	CHF 463.41	100	●	◀
The Swatch Group Financial Services (Luxembourg) SA, Alzingen	Finance company	EUR 5.00	100	●	◀
The Swatch Group Re (Luxembourg) SA, Alzingen	Reinsurance	EUR 1.80	100	●	◀
Netherlands					
The Swatch Group (Netherlands) BV, Eindhoven	Distribution	EUR 3.45	100	●	◀
Poland					
The Swatch Group (Polska) Sp.zo.o., Warszawa	Distribution	PLN 10.00	100	●	◀
Russia					
Swiss Watch Le Prestige OOO Russia, Moscow	Distribution	RUB 0.20	100	●	◀
The Swatch Group (RUS) OOO, Moscow	Distribution	RUB 5 777.57	100	●	◀
Sweden					
The Swatch Group (Nordic) AB, Stockholm	Distribution	SEK 0.50	100	●	◀
Czech Republic					
ASICentrum spol. s.r.o., Praha	Microelectronics	CZK 0.30	51	●	▶
ST Software s.r.o., Liberec	Sports timing technology & equipment	CZK 0.10	80	●	▶
The Swatch Group (CZ) Les Boutiques s.r.o., Praha	Retail	CZK 9.00	100	●	◀
Turkey					
The Swatch Group Turkey Saat Ticaret Limited Sirketi, Istanbul	Distribution	TRY 46.00	100	●	◀

Legend: ● Fully consolidated ○ Equity method ◀ Watches & Jewelry ▶ Electronic Systems ▼ Corporate

NOTES TO THE CONSOLIDATED FINANCIAL STATEMENTS

32. The Swatch Group Companies – as at 31.12.2014

Company name, Registered offices	Field of Activity	Capital in millions	Swatch Group Shareholdings %	Consolidation	Segment
Asia					
Bahrain					
Hour Choice W.L.L., Manama	Retail	BHD 0.02	58	●	◀
Greater China					
Beijing Xin Yu Heng Rui Watch & Clock Co., Ltd., Beijing	Real estate	CNY 40.00	50	○	▶
Harry Winston Commercial (China) Co. Ltd., Beijing	Retail	CNY 78.96	100	●	▶
Harry Winston (Hong Kong) Limited, Hong Kong	Retail	HKD 0.01	100	●	▶
Hengdeli Holdings Limited, Hong Kong	Retail	CNY 22.94	9	○	▶
Lanco Watches Ltd, Hong Kong	Administration	USD 0.07	100	●	▶
O Grupo Swatch (Macau) Limitada, Macau	Retail	MOP 1.50	100	●	▶
Shanghai Ruihengqi Watch Commerce Co. Ltd., Shanghai	Retail	CNY 30.00	50	●	▶
Shanghai Rui Jing Retail Co., Ltd., Shanghai	Retail	CNY 20.25	100	●	▶
Shanghai Rui Wan Retail Co. Ltd., Shanghai	Retail	CNY 4.00	100	●	▶
Shanghai SMH Watch Service Center Co. Ltd, Shanghai	Customer service	CNY 48.37	100	●	▶
Shanghai Swatch Art Centre Co. Ltd., Shanghai	Art center	CNY 148.41	90	●	▶
SMH Les Boutiques (Shanghai) Co. Ltd, Shanghai	Retail	CNY 99.69	100	●	▶
SMH Swiss Watch Trading (Shanghai) Co. Ltd, Shanghai	Distribution	CNY 7.12	90	●	▶
SMH Technical Services (Shenzhen) Co. Ltd., Shenzhen	Services	CNY 10.45	100	●	▶
The Swatch Group (China) Ltd, Shanghai	Distribution	CNY 14.88	100	●	▶
The Swatch Group (Hong Kong) Ltd, Hong Kong	Distribution	HKD 5.00	100	●	▶
The Swatch Group (Taiwan) Ltd, Taipei	Distribution	TWD 28.00	100	●	▶
Zhuhai SMH Electric Co. Ltd, Zhuhai	Assembly electronic components	CNY 74.57	100	●	▶
Oman					
Rivoli & Co. L.L.C., Muscat	Retail	OMR 0.30	58	●	▶
Qatar					
Hour Choice W.L.L., Doha	Retail	QAR 0.20	58	●	▶
Rivoli Watches W.L.L., Doha	Retail	QAR 0.40	58	●	▶
South Korea					
The Swatch Group (Korea) Ltd, Seoul	Distribution	KRW 6 300.00	100	●	▶
Saudi Arabia					
Alzouman General Trading Co. Ltd., Jeddah	Retail	SAR 60.00	33	○	▶
United Arab Emirates					
Al Khaleej Watches L.L.C., Abu Dhabi	Retail	AED 0.15	58	●	▶
Blue Sky Trading Company L.L.C., Abu Dhabi	Retail	AED 0.30	58	●	▶
Excel Enterprises L.L.C., Dubai	Retail	AED 1.70	58	●	▶
Golden Watch Company L.L.C., Abu Dhabi	Retail	AED 0.50	58	●	▶
Hour Choice L.L.C., Dubai	Retail	AED 3.00	58	●	▶
New Horizons General Trading L.L.C., Dubai	Retail	AED 0.30	29	○	▶
Rivoli Arcade L.L.C., Dubai	Retail	AED 0.30	58	●	▶
Rivoli Enterprises L.L.C., Dubai	Retail	AED 3.00	58	●	▶
Rivoli Group L.L.C., Dubai	Retail	AED 24.02	58	●	▶
Rivoli Investments L.L.C., Dubai	Holding	AED 0.30	58	●	▶
Rivoli International L.L.C., Dubai	Administration	AED 0.30	58	●	▶
Rivoli Textiles L.L.C., Dubai	Retail	AED 0.30	58	●	▶
Swatch Group Retail Middle East L.L.C., Dubai	Retail	AED 0.30	49	●	▶
Vision 2000 L.L.C., Dubai	Retail	AED 1.00	58	●	▶
India					
Swatch Group (India) Private Ltd, New Delhi	Distribution	INR 4 080.00	100	●	▶
Indonesia					
PT Swatch Group Indonesia, Jakarta	Distribution	IDR 4 682.17	100	●	▶
Japan					
Harry Winston Japan KK, Tokyo	Retail	JPY 10.00	100	●	▶
The Swatch Group (Japan) KK, Tokyo	Distribution	JPY 3 700.00	100	●	▶
Malaysia					
Micromechanics (M) Sdn Bhd, Ipoh	Assembly electronic components	MYR 35.00	100	●	▶
Swiss Luxury Watch & Jewelry Sdn Bhd, Kuala Lumpur	Retail	MYR 7.00	51	●	▶
The Swatch Group (Malaysia) Sdn Bhd, Kuala Lumpur	Distribution	MYR 1.00	100	●	▶
Singapore					
Harry Winston N.A. Pte Ltd, Singapore	Retail	SGD 0.00	100	●	▶
The Swatch Group S.E.A. (S) Pte Ltd, Singapore	Distribution	SGD 4.00	100	●	▶
The Swatch Group S.E.A. Retail Pte Ltd, Singapore	Retail	SGD 0.50	100	●	▶
Thailand					
ETA (Thailand) Co. Ltd, Samut Prakan	Assembly electronic components	THB 504.50	100	●	▶
The Swatch Group Trading (Thailand) Ltd, Bangkok	Distribution	THB 400.00	100	●	▶

Legend: ● Fully consolidated ○ Equity method ◀ Watches & Jewelry ▶ Electronic Systems ▼ Corporate

NOTES TO THE CONSOLIDATED FINANCIAL STATEMENTS

32. The Swatch Group Companies – as at 31.12.2014

Company name, Registered offices	Field of Activity	Capital in millions	Swatch Group Shareholdings %	Consoli- dation	Segment
America					
Brazil					
SGA Administração de Imóveis SA, Manaus	Administration	BRL 4.92	100	●	◀
SGB Importação e Varejo de Artigos de Luxo Ltda., São Paulo	Retail	BRL 44.30	100	●	◀
SGB Serviços e Comércio de Peças Ltda, São Paulo	Customer service	BRL 45.26	100	●	◀
SMH do Brasil Administração de Bens Ltda, São Paulo	Administration	BRL 27.60	100	●	▼
Canada					
H.W. Protection Inc., Toronto	Services	CAD 1.94	100	●	◀
The Swatch Group (Canada) Ltd, Toronto	Distribution	CAD 4.50	100	●	◀
United States					
EM Microelectronic – US Inc., Colorado Springs	Microelectronics	USD 0.04	100	●	▶
Harry Winston Inc., New York	High jewelry	USD 0.60	100	●	◀
HiPoint Technology Inc., Colorado Springs	Microelectronics	USD 0.17	25	○	▶
HW Holdings Inc., Wilmington, Delaware	Holding	USD 0.00	100	●	◀
The Swatch Group (U.S.) Inc., Wilmington, Delaware	Distribution	USD 168.90	100	●	◀
Mexico					
Operadora y Comercializadora de Relojes y Joyería SA de CV, Mexico	Services	MXN 1.50	100	●	◀
The Swatch Group Mexico SA de CV, Mexico DF	Distribution	MXN 43.65	100	●	◀
Panama					
The Swatch Group Panama SA, Panama City	Services, marketing, distribution	USD 0.01	100	●	◀
Oceania					
Australia					
The Swatch Group (Australia) Pty Ltd, Glen Iris	Distribution	AUD 0.40	100	●	◀
Africa					
South Africa					
The Swatch Group (South Africa) (Proprietary) Ltd, Sandton	Distribution	ZAR 0.00	100	●	◀

REPORT OF THE STATUTORY AUDITOR TO THE GENERAL MEETING OF THE SWATCH GROUP LTD, NEUCHÂTEL

Report of the statutory auditor on the consolidated financial statements

As statutory auditor, we have audited the consolidated financial statements of The Swatch Group Ltd, which comprise the income statement, balance sheet, statement of cash flows, statement of changes in equity and notes (pages 163 to 204), for the year ended 31 December 2014.

Board of Directors' responsibility

The Board of Directors is responsible for the preparation and fair presentation of the consolidated financial statements in accordance with Swiss GAAP FER and the requirements of Swiss law. This responsibility includes designing, implementing and maintaining an internal control system relevant to the preparation and fair presentation of consolidated financial statements that are free from material misstatement, whether due to fraud or error. The Board of Directors is further responsible for selecting and applying appropriate accounting policies and making accounting estimates that are reasonable in the circumstances.

Auditor's responsibility

Our responsibility is to express an opinion on these consolidated financial statements based on our audit. We conducted our audit in accordance with Swiss law and Swiss Auditing Standards. Those standards require that we plan and perform the audit to obtain reasonable assurance whether the consolidated financial statements are free from material misstatement.

An audit involves performing procedures to obtain audit evidence about the amounts and disclosures in the consolidated financial statements. The procedures selected depend on the auditor's judgment, including the assessment of the risks of material misstatement of the consolidated financial statements, whether due to fraud or error. In making those risk assessments, the auditor considers the internal control system relevant to the entity's preparation and fair presentation of the consolidated financial statements in order to design audit procedures that are appropriate in the circumstances, but not for the purpose of expressing an opinion on the effectiveness of the entity's internal control system. An audit also includes evaluating the appropriateness of the accounting policies used and the reasonableness of accounting estimates made, as well as evaluating the overall presentation of the consolidated financial statements. We believe that the audit evidence we have obtained is sufficient and appropriate to provide a basis for our audit opinion.

Opinion

In our opinion, the consolidated financial statements for the year ended 31 December 2014 give a true and fair view of the financial position, the results of operations and the cash flows in accordance with Swiss GAAP FER and comply with Swiss law.

Report on other legal requirements

We confirm that we meet the legal requirements on licensing according to the Auditor Oversight Act (AOA) and independence (article 728 CO and article 11 AOA) and that there are no circumstances incompatible with our independence.

In accordance with article 728a paragraph 1 item 3 CO and Swiss Auditing Standard 890, we confirm that an internal control system exists which has been designed for the preparation of consolidated financial statements according to the instructions of the Board of Directors.

We recommend that the consolidated financial statements submitted to you be approved.

PricewaterhouseCoopers AG

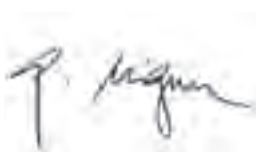

Gerhard Siegrist
Audit expert
Auditor in charge



Roy Bächinger
Audit expert

Basel, 20 February 2015

TABLE OF CONTENTS

Financial statements of the Holding 2014	206–216
Income statement of the Holding	207
Balance sheet of the Holding	208
Notes to the financial statements of the Holding	210
Proposed appropriation of available earnings	215
Report of the statutory auditor on the financial statements	216

INCOME STATEMENT OF THE HOLDING

	Notes	2014 CHF million	2013 CHF million
Income from investments in subsidiaries	(1)	1 135	1 636
Other income	(2)	5	416
Personnel expense		- 55	- 55
Other expenses		- 15	- 16
Depreciation and impairment	(3)	- 7	- 174
Financial expenses	(4)	- 21	- 12
Other financial income	(5)	33	114
Ordinary result		1 075	1 909
Non-operating result	(6)	0	0
Extraordinary result	(6)	0	0
Income before taxes		1 075	1 909
Income taxes		- 1	- 29
Net income		1 074	1 880

BALANCE SHEET OF THE HOLDING

Assets	Notes	31.12.2014		31.12.2013	
		CHF million	%	CHF million	%
Current assets					
Cash and cash equivalents		193	3.2	95	1.8
Assets with an observable market price	(7, 10)	96	1.6	127	2.3
Other current receivables					
– from Group companies	(8)	2 220	36.2	1 641	30.3
– from third parties		53	0.9	49	0.9
Prepayments and accrued income		2	0.0	432	8.0
Total current assets		2 564	41.9	2 344	43.3
Non-current assets					
Loans to Group companies	(8)	440	7.2	5	0.1
Investments in subsidiaries and associates	(9)	3 113	50.8	3 056	56.4
Tangible assets		9	0.1	9	0.2
Intangible assets		1	0.0	1	0.0
Total non-current assets		3 563	58.1	3 071	56.7
Total assets		6 127	100.0	5 415	100.0

BALANCE SHEET OF THE HOLDING

Equity and liabilities	Notes	31.12.2014		31.12.2013	
		CHF million	%	CHF million	%
Current liabilities					
Financial debts and derivative financial instruments	(10)	32	0.5	11	0.2
Other current liabilities					
– to Group companies		51	0.8	49	0.9
– to third parties		6	0.1	4	0.1
Accrued expenses		20	0.3	46	0.8
Non-current liabilities					
Non-current provisions		90	1.5	90	1.7
Total liabilities		199	3.2	200	3.7
Equity					
Share capital		125	2.0	125	2.3
Statutory capital reserve		82	1.4	57	1.1
Statutory reserve		10	0.2	10	0.2
Voluntary reserve		4 860	79.3	3 336	61.6
– Profit brought forward		35		32	
– Net income for the year		1 074		1 880	
Available earnings		1 109	18.1	1 912	35.3
Treasury shares		– 258	– 4.2	– 225	– 4.2
Total equity	(11)	5 928	96.8	5 215	96.3
Total equity and liabilities		6 127	100.0	5 415	100.0

NOTES TO THE FINANCIAL STATEMENTS

General

The financial statements of The Swatch Group Ltd, with registered office in Neuchâtel comply with the requirements of the Swiss law for companies, the Swiss Code of Obligations (SCO). The 2014 financial statements were prepared for the first time in accordance with the Swiss Accounting Legislation (Title 32 of the Swiss Code of Obligations). To ensure comparability, prior-year balance sheet and income statement information was adjusted to the new classification requirements.

Valuation principles

Assets are valued at no more than their acquisition cost. Exceptions are current assets with market value, which are valued at the exchange rate or market value on the balance sheet date. All changes in value are recognized in the income statement. No value fluctuation reserves are built. Investments in subsidiaries and associates are valued individually provided that they are significant and that due to their similarity they are not usually combined as a group for valuation.

Until 2013 treasury shares reserved for the stock option plan, as well as repurchased treasury shares, were shown at lower of cost or market. As of 2014 treasury shares are valued at historical acquisition value without subsequent valuation adjustment. Gains and losses from disposals of treasury shares, including transaction costs, are recorded directly in capital reserves. Liabilities are valued at nominal value.

All assets and liabilities denominated in foreign currencies are translated according to the exchange rates applicable on the balance sheet date. Income and expenses denominated in foreign currencies and all foreign exchange transactions are translated at the exchange rates prevailing on their respective transaction dates. Resulting foreign exchange differences are recognized in the income statement.

Details to specific items

1. Income from investments in subsidiaries

(CHF million)	2014	2013
Dividends	1 071	1 565
Other income from investments in subsidiaries	64	71
Total	1 135	1 636

This item includes dividends from Group companies and other income from investments in subsidiaries as well as management fees from Group companies.

2. Other income

In 2014, other income was CHF 5 million. In 2013, this position included in particular income from the successful outcome of the legal case against Tiffany & Co. USA.

3. Depreciation and impairment

Depreciation and impairment was CHF 7 million (previous year: CHF 174 million resulting from impairment charges on loans and investments in subsidiaries).

4. Financial expenses

In both 2014 and 2013, interest expense was less than CHF 1 million. The valuation of foreign currency hedging contracts taken out in favor of various Group companies resulted in a loss of CHF 17 million (2013: loss of CHF 5 million). The loss recorded on the marketable securities portfolio, including other financial expenses, amounted to CHF 4 million (2013: loss of CHF 7 million).

5. Other financial income

(CHF million)	2014	2013
Interest income	21	34
Income and gains on securities	12	80
Total	33	114

The company recorded capital gains of CHF 12 million on its investment portfolio (previous year: CHF 80 million, of which CHF 48 million from the sale of treasury shares). As of 2014 gains and losses from disposals of treasury shares, including transaction costs, are recorded directly in capital reserves.

6. Non-operating / extraordinary result

Both the non-operating and extraordinary results were less than CHF 1 million in the year under review (previous year: both less than CHF 1 million).

NOTES TO THE FINANCIAL STATEMENTS

7. Assets with an observable market price	(CHF million)	31.12.2014	31.12.2013
Marketable securities		86	102
Precious metals		8	20
Derivative financial instruments (see Note 10)		2	5
Total		96	127

The item "Precious metals" consists mainly of a strategic long position in gold. The position "treasury shares" has been reclassified into equity.

8. Receivables and loans This position mainly includes deposits of surplus cash with the Group-internal finance company in Luxembourg as well as financing of subsidiaries.

9. Investments in subsidiaries and associates The list of 171 legal entities, including minority investments, held directly or indirectly by the company and consolidated at Swatch Group level, is published in Note 32 of the consolidated financial statements in this report. Investments in subsidiaries accounted for 50.8% of total assets at 31 December 2014 versus 56.4% at end-2013. In absolute terms, the value of investments in subsidiaries amounted to CHF 3 113 million at end-2014. This amount corresponds to consolidated investments and investments in associates, and is CHF 57 million higher than in 2013.

10. Derivative financial instruments The following table shows the contract and replacement values of derivative financial instruments at 31 December 2014.

Type	Contract value			Positive replacement value			Negative replacement value		
	Third party	Group	Total	Third party	Group	Total	Third party	Group	Total
(CHF million)									
Forward contracts	1 424	415	1 839	0	2	2	-28	-4	-32
Options	-	-	-	-	-	-	-	-	-
Total at 31.12.2014	1 424	415	1 839	0	2	2	-28	-4	-32
Total at 31.12.2013	1 118	392	1 510	0	5	5	-8	-3	-11

Derivative financial instruments are recognized at fair value. Positions outstanding at 31 December 2014 serve to hedge operations relating to exchange rate risk and market volatility. Forward contracts outstanding at 31 December 2014 relate to 32 positions held in precious metals and in foreign currencies (previous year: 32). Intragroup contracts relate to agreements between The Swatch Group Ltd and Group companies for the hedging of risk associated with intragroup financial transactions. At 31 December 2014, there was no option outstanding (none in the previous year).

11. Equity Compared with end-2013, equity increased by CHF 713 million to CHF 5 928 million in 2014. In percentage of total assets the equity ratio increased to 96.8% at 31 December 2014 (versus 96.3% in the previous year).

The table below shows the changes in equity:

	Share capital	Statutory capital reserve	Statutory reserve	Voluntary reserve	Available earnings	Treasury shares	Total equity
(CHF million)							
Balance at 31.12.2013	125	57	10	3 336	1 912	- 225	5 215
Allocated in 2014				1 470	- 1 470		-
Dividend paid out					- 407		- 407
Sale/Repurchase treasury shares		25				- 33	- 8
Mergers				54			54
Net income for the year					1 074		1 074
Balance at 31.12.2014	125	82	10	4 860	1 109	- 258	5 928

NOTES TO THE FINANCIAL STATEMENTS

Share capital

At 31 December 2014, share capital consisted of 124 045 000 registered shares each with a nominal value of CHF 0.45, and of 30 840 000 bearer shares each with a nominal value of CHF 2.25 (unchanged from the previous year).

Balance sheet date	Registered shares	Bearer shares	Share capital in CHF
31.12.2013	124 045 000 at CHF 0.45	30 840 000 at CHF 2.25	125 210 250.00
31.12.2014	124 045 000 at CHF 0.45	30 840 000 at CHF 2.25	125 210 250.00

Principal shareholders at 31 December 2014

At 31 December 2014, the Hayek Pool, its related companies, institutions and individuals held 63 169 930 registered shares and 1 650 bearer shares, equivalent to 40.8% of the shares issued at this date (previous year: 40.8%). The Hayek Pool comprises the following members:

Name/Company	Location	Beneficial owners
Community of heirs of N.G. Hayek represented by Marianne Hayek	Meisterschwanden	Community of heirs of N. G. Hayek
WAT Holding AG	Meisterschwanden	Community of heirs of N. G. Hayek
Ammann Group Holding AG	c/o Ernst & Young AG, Bern	Descendants U. Ammann-Schellenberg sen.
Swatch Group Pension Fund	Neuchâtel	—

The companies, institutions and individuals associated with the Hayek Pool, but which do not formally belong to the Hayek Pool are as follows:

Name/Company	Location	Beneficial owners
Hayek Holding AG	Meisterschwanden	Community of heirs of N. G. Hayek
Community of heirs of N. G. Hayek and family members		Community of heirs of N. G. Hayek
Personalfürsorgestiftung der Hayek Engineering AG	Meisterschwanden	—
Ammann families (pension funds, foundations and individuals, Madisa AG)	c/o Ernst & Young AG, Bern	Represented by Daniela Schneider
Fondation d'Ebauches SA et des maisons affiliées	Neuchâtel	—
Various welfare foundations	various	—

In the context of the pool, the group of the community of heirs of N. G. Hayek and related parties controlled in total 40.4% of the shares issued at end-2014 (previous year: 40.4%).

Mrs. Esther Grether's group controlled 5.9% of the shares issued (previous year: 7.1%).

At 31 December 2014, the Swatch Group was not aware of any other group or individual shareholder having an interest of more than 5% of the total share capital.

Statutory capital reserve / Statutory reserve

The general reserve was separated into the statutory capital reserve and statutory reserve. As of 2014, gains and losses from the sale of treasury shares, including transaction costs, are recorded directly in the statutory capital reserve. In addition, the statutory capital reserve includes the historical proceeds from the issuance of participation certificates in excess of nominal value and issuance costs (premium).

Voluntary reserve

In 2014, the company Look and Feel Ltd was merged into The Swatch Group Ltd. The merger profit of CHF 54 million was added to the voluntary reserve. The position "Reserve for treasury shares" in the amount of CHF 268 million was dissolved and transferred to the voluntary reserve. The position "Treasury shares" in the amount of CHF 225 million at the end of 2013 was transferred from assets with an observable market price to equity. Finally, CHF 1 470 million was appropriated from available earnings at 31 December 2013 and allocated to the voluntary reserve.

NOTES TO THE FINANCIAL STATEMENTS

Available earnings

In compliance with the resolution approved at the Annual General Meeting of 14 May 2014, a dividend of CHF 1.50 per registered share and of CHF 7.50 per bearer share was appropriated from available earnings as at 31 December 2013. The total dividend amount paid to shareholders in 2014 came to CHF 186 million on the registered shares and CHF 231 million on the bearer shares. In accordance with the resolution relating to the use of available earnings approved by the above-mentioned AGM, no dividends were paid on the treasury shares held by the Swatch Group. This amount, which would have totaled CHF 10 million, thus constituted an integral part of equity at 31 December 2014. Finally, CHF 1 470 million was appropriated from available earnings at 31 December 2013 and allocated to the voluntary reserve.

Treasury shares

The total value of treasury shares held by The Swatch Group Ltd and its subsidiaries at 31 December 2014 corresponded to 2.4% (versus 2.4% at end-2013) of the nominal value of total share capital. In addition to repurchased treasury shares, this position also includes registered treasury shares intended for the employee stock option plan.

The number of treasury shares held directly or indirectly by The Swatch Group Ltd changed in 2014 as shown in the table below:

Shares held by:	Registered shares	Bearer shares
	Quantity ¹⁾	Quantity
The Swatch Group Ltd		
Balance at 31.12.2013	4 126 296	505 000
Acquisitions in 2014 ²⁾	385 000	164 000
Disposals in 2014 ³⁾	- 252 308	- 164 000
Balance at 31.12.2014	4 258 988	505 000
Other consolidated companies		
Balance at 31.12.2013	-	-
Acquisitions in 2014	-	-
Disposals in 2014	-	-
Balance at 31.12.2014	-	-
Total balance at 31.12.2014	4 258 988	505 000

¹⁾ of which at 31 December 2014 a total of 1 154 463 registered shares were reserved for the management stock option plan (1 396 771 registered shares in 2013).

²⁾ In 2014, the Group acquired 385 000 registered shares at an average price of CHF 86.28 each. The Group also acquired 164 000 bearer shares at an average price of CHF 448.63 each.

³⁾ In 2014, the Group sold 10 000 registered shares at an average price of CHF 87.95 each. The remaining disposals of registered shares relate to the employee stock option plan. Details of the share options granted in connection with the employee stock option plan are provided in Note 29. The Group also sold 164 000 bearer shares at an average price of CHF 466.11 each.

Off-balance-sheet items

Number of full-time equivalents

In 2014, the annual average number of full-time equivalents was 153 (2013: 154).

Leasing liabilities

The balance of liabilities arising from sale-like contracts and other leasing commitments which do not expire or cannot be cancelled within 12 months amounted to less than CHF 1 million at 31 December 2014 (previous year: less than CHF 1 million).

Liabilities to pension plans

The balance sheet as at end-2014 contained no liabilities to pension plans (previous year: less than CHF 1 million).

Assets pledged

None of the company's assets are pledged.

Guarantees

At end-2014, guarantees provided by The Swatch Group Ltd amounted to less than CHF 1 million (previous year: less than CHF 1 million). This item relates to a guarantee to cover a lease commitment taken out by one of the Group's companies (unchanged to 2013).

Contingent liabilities

There were no contingent liabilities at the end of 2014 (previous year: none).

NOTES TO THE FINANCIAL STATEMENTS

Swatch Group shares and options of the Board of Directors, Group Management and employees

Article 959c paragraph 2 item 11 of the Swiss Code of Obligations require disclosure of the number and value of shares and options granted to members of the Board of Directors and Group Management as well as to employees. This information is disclosed in Note 29 of the consolidated financial statements.

In addition, Article 663c paragraph 3 of the Swiss Code of Obligations require disclosure of shares and options held by members of the Board of Directors and Group Management, including closely related persons. The table below shows the corresponding holdings at 31 December 2014 and 2013:

Name	Function	Registered Shares (number)		Bearer Shares (number)		Options (number)	
		2014	2013	2014	2013	2014	2013
Community of heirs N. G. Hayek represented by Marianne Hayek		55 704 144	55 704 144	550	550		
Nayla Hayek	BoD Chairwoman	88 208	68 208			20 002	20 002
Ernst Tanner	BoD Vice-Chairman			2 000	2 000		
Esther Grether ¹⁾	BoD Member		10 868 000		114 000		
Prof. Dr. h.c. Claude Nicollier	BoD Member						
Dr. Jean-Pierre Roth	BoD Member			10			
Georges Nicolas Hayek	BoD Member / CEO	77 991	56 491			24 000	24 000
Pierre-André Bühler	MB Member	17 366	12 866			8 002	7 502
Dr. Mougahed Darwish	MB Member	71 068	67 336			2 602	3 734
Marc A. Hayek	MB Member	93 398	80 898			12 502	12 502
Dr. Thierry Kenel	MB Member / CFO	38 252	30 252			8 002	8 002
Florence Ollivier-Lamarque	MB Member	50 668	40 668			12 000	12 000
Dr. Hanspeter Rentsch	MB Member / CLO	97 522	95 022	200	200	19 001	19 001
François Thiébaud	MB Member	93 123	84 623			12 502	12 502
Raynald Aeschlimann	EMB Member	9 867	6 033			4 001	3 835
Matthias Breschan	EMB Member	3 034	3 034			3 000	3 000
Jean-Claude Eggen	EMB Member	3 616	2 616			2 501	2 001
Yann Gamard	EMB Member		7 801			5 501	5 501
Hans-Rudolf Gottier	EMB Member	26 048	30 648			5 002	4 902
Walter von Känel	EMB Member	42 879	36 393	40	40	6 000	6 000
Thomas Meier	EMB Member	2 400	1 200			1 200	1 200
Calogero Polizzi	EMB Member	5 536	4 004			2 002	1 534
Kevin Rollenhagen	EMB Member	40 148	52 148			8 002	8 002
Dr. Peter Steiger	EMB Member	67 257	60 257			8 668	7 668
Stephen Urquhart	EMB Member	38 500	32 000			6 502	6 502
Total		56 571 025	67 344 642	2 800	116 790	170 992	169 390

¹⁾ BoD Member until May 2014.

Each option gives the right to conversion into one registered share. Each share (registered or bearer) represents one voting right. The principal shareholders are disclosed in Note 30 of the consolidated financial statements. Except for the community of heirs of N. G. Hayek, no member of the Board of Directors, Management Board and Extended Management Board, together with persons closely linked to them, owned as of 31 December 2014, either directly or through share options, more than 1% of the outstanding Swatch Group shares (end of 2013: community of heirs of N. G. Hayek and Mrs. E. Grether).

Management compensation details can be found in the separate compensation report.

Additional information, cash flow statement and management report

According to Article 961d paragraph 1 of the Swiss Code of Obligations, additional information, the statement of cash flows and the management report are dispensed with, as the Swatch Group AG prepares the consolidated financial statements in accordance with a recognized financial reporting standard.

Events after the balance sheet date

These financial statements were approved for issue by the Board of Directors on 20 February 2015 and will be submitted to the Annual General Meeting of Shareholders for approval on 28 May 2015.

There were no other significant events after the balance sheet date.

PROPOSED APPROPRIATION OF AVAILABLE EARNINGS

The Board of Directors proposes to the Annual General Meeting that available earnings be appropriated as follows:

	2014	2013
	CHF	CHF
Net income for the year	1 074 510 104	1 880 341 359
Profit brought forward from previous year	34 681 336	31 731 285
Available earnings	1 109 191 440	1 912 072 644
Allocation to special reserve	- 670 000 000	- 1 470 000 000
Payment on share capital of CHF 125 210 250.00 of a 2013 dividend, i.e.:		
– CHF 1.50 per registered share with a par value of CHF 0.45		– 186 067 500
– CHF 7.50 per bearer share with a par value of CHF 2.25		– 231 300 000
Payment on share capital of CHF 125 210 250.00 ¹⁾ of a 2014 dividend, i.e.:		
– CHF 1.50 per registered share with a par value of CHF 0.45	– 186 067 500	
– CHF 7.50 per bearer share with a par value of CHF 2.25	– 231 300 000	
Dividends not paid out on own shares held by the Group ²⁾		9 976 191
Balance carried forward	21 823 940	34 681 335

¹⁾ It is planned not to pay dividends on own shares held by the Group.

²⁾ Based on the decision of the Annual General Meeting of 14 May 2014, the dividend due on own shares held by the Group was not paid out.

REPORT OF THE STATUTORY AUDITOR TO THE GENERAL MEETING OF THE SWATCH GROUP LTD, NEUCHÂTEL

Report of the statutory auditor on the financial statements

As statutory auditor, we have audited the financial statements of The Swatch Group Ltd, which comprise the income statement, balance sheet and notes (pages 207 to 214), for the year ended 31 December 2014.

Board of Directors' responsibility

The Board of Directors is responsible for the preparation of the financial statements in accordance with the requirements of Swiss law and the company's articles of incorporation. This responsibility includes designing, implementing and maintaining an internal control system relevant to the preparation of financial statements that are free from material misstatement, whether due to fraud or error. The Board of Directors is further responsible for selecting and applying appropriate accounting policies and making accounting estimates that are reasonable in the circumstances.

Auditor's responsibility

Our responsibility is to express an opinion on these financial statements based on our audit. We conducted our audit in accordance with Swiss law and Swiss Auditing Standards. Those standards require that we plan and perform the audit to obtain reasonable assurance whether the financial statements are free from material misstatement.

An audit involves performing procedures to obtain audit evidence about the amounts and disclosures in the financial statements. The procedures selected depend on the auditor's judgment, including the assessment of the risks of material misstatement of the financial statements, whether due to fraud or error. In making those risk assessments, the auditor considers the internal control system relevant to the entity's preparation of the financial statements in order to design audit procedures that are appropriate in the circumstances, but not for the purpose of expressing an opinion on the effectiveness of the entity's internal control system. An audit also includes evaluating the appropriateness of the accounting policies used and the reasonableness of accounting estimates made, as well as evaluating the overall presentation of the financial statements. We believe that the audit evidence we have obtained is sufficient and appropriate to provide a basis for our audit opinion.

Opinion

In our opinion, the financial statements for the year ended 31 December 2014 comply with Swiss law and the company's articles of incorporation.

Report on other legal requirements

We confirm that we meet the legal requirements on licensing according to the Auditor Oversight Act (AOA) and independence (article 728 CO and article 11 AOA) and that there are no circumstances incompatible with our independence.

In accordance with article 728a paragraph 1 item 3 CO and Swiss Auditing Standard 890, we confirm that an internal control system exists which has been designed for the preparation of financial statements according to the instructions of the Board of Directors.

We further confirm that the proposed appropriation of available earnings complies with Swiss law and the company's articles of incorporation. We recommend that the financial statements submitted to you be approved.

PricewaterhouseCoopers AG

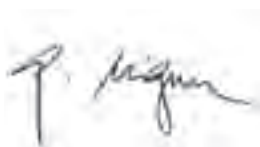

Gerhard Siegrist
Audit expert
Auditor in charge



Roy Bächinger
Audit expert

Basel, 20 February 2015

THE SWATCH GROUP LTD SECURITIES

Average number of shares outstanding/ Average share capital	Swiss GAAP FER			IFRS		
	2014	2013	2012	2011	2010	
	basic	basic	basic	basic	basic	
Number of registered shares of CHF 0.45	119 894 096	119 514 584	118 195 194	118 399 729	113 103 548	
Number of bearer shares of CHF 2.25	30 320 769	30 335 000	30 335 000	30 335 000	30 335 000	
Total average number of shares outstanding	150 214 865	149 849 584	148 530 194	148 734 729	143 438 548	
Share capital registered shares of CHF 0.45	53 952 343	53 781 563	53 187 838	53 279 878	50 896 597	
Share capital bearer shares of CHF 2.25	68 221 730	68 253 750	68 253 750	68 253 750	68 253 750	
Total average share capital	122 174 073	122 035 313	121 441 588	121 533 628	119 150 347	
Key data per registered share (nom CHF 0.45) in CHF						
Consolidated net income	5.10	7.08	5.91	4.70	4.05	
Cash flow from operating activities	6.81	4.83	3.70	2.61	5.11	
Consolidated shareholders' equity	39.32	35.30	31.77	29.82	26.77	
Dividend	1.50¹⁾	1.50	1.35	1.15	1.00	
Key data per bearer share (nom CHF 2.25) in CHF						
Consolidated net income	25.49	35.41	29.57	23.50	20.27	
Cash flow from operating activities	34.03	24.13	18.51	13.05	25.55	
Consolidated shareholders' equity	196.58	176.52	158.84	149.11	133.83	
Dividend	7.50¹⁾	7.50	6.75	5.75	5.00	
Stock price of registered shares (adjusted)						
High	108.00	104.40	80.40	79.50	78.50	
Low	75.35	80.20	59.90	51.60	50.40	
31.12.	86.00	100.40	78.75	62.60	75.40	
Stock price of bearer shares (adjusted)						
High	597.00	606.50	471.70	443.70	434.80	
Low	417.10	473.00	341.70	288.50	262.20	
31.12.	444.20	589.50	461.20	351.50	416.80	
Market capitalization (CHF million)						
31.12.	24 367	30 634	23 992	18 605	22 207	
Key ratios (year-end)						
Average return on equity	%	14.0	21.2	19.7	16.8	16.5
Dividend yield registered shares	%	1.7	1.5	1.7	1.8	1.6
Dividend yield bearer shares	%	1.7	1.3	1.5	1.6	1.5
Price/earnings ratio – registered shares		16.9	14.2	13.3	13.3	18.6
Price/earnings ratio – bearer shares		17.4	16.7	15.6	15.0	20.6

1) Board of Directors' proposal.

As of 2013, the consolidated financial statements have been prepared in accordance with Swiss GAAP FER. For comparison purposes, 2012 has been restated.

Securities

	ISIN no.	Reuters Symbol
The Swatch Group Ltd registered shares	CH0012255144	UHRN.S
The Swatch Group Ltd bearer shares	CH0012255151	UHR.VX

The securities are listed on the Swiss Stock Exchange (SIX) and on the BX Berne eXchange

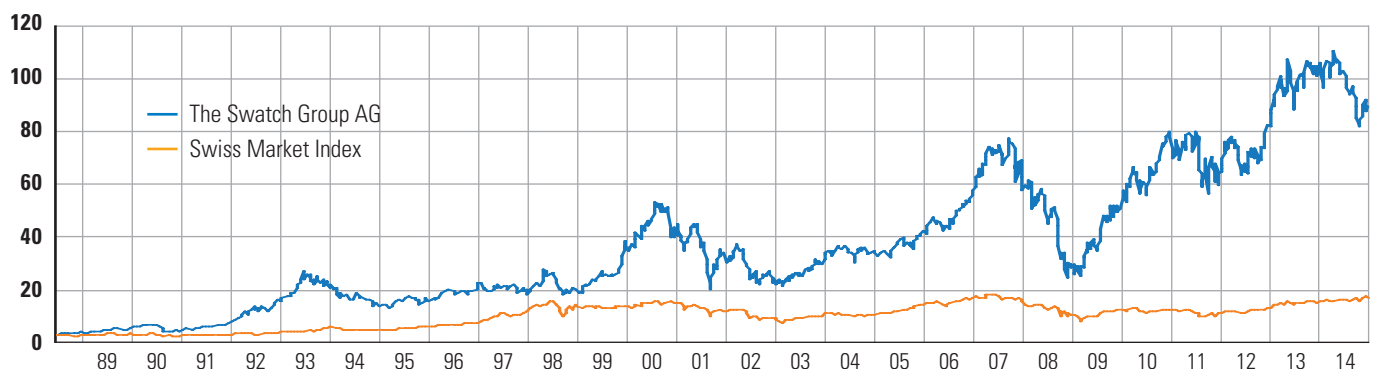
Evolution of the Swatch Group Ltd registered shares and the Swiss Market Index (1988–2014)



COMPENSATION REPORT



TABLE OF CONTENTS

Compensation Committee	3
Compensation system	4
Additional contractual elements	6
Compensation for the members of the Board of Directors and Group Management (KL/EKL) in 2014	7
Report of the External Auditor to the General Meeting of The Swatch Group Ltd, Neuchâtel	9

COMPENSATION REPORT

Dear Ladies and Gentlemen

In accordance with the Ordinance against Excessive Compensation in Listed Stock Corporations (Compensation Ordinance; Verordnung gegen übermässige Vergütungen bei börsenkotierten Aktiengesellschaften, VegüV), which came into force on 1 January 2014, all information regarding the compensation of the Board of Directors and the Group Management (Executive Group Management Board and Extended Group Management Board) is now presented in the Compensation Report.

With the Compensation Report, the Board of Directors and the Compensation Committee give an account of the material elements of the compensation principles, of the tasks and competences in the field of compensation, of the composition and function of the Compensation Committee, and of the various compensation elements.

The aim of the Compensation Report is to create transparency regarding the compensation provided by the company.

For the first time at the 2015 General Meeting, you will be able to vote on the compensation of the members of the Board of Directors and the Group Management (Executive Group Management Board, Extended Group Management Board).

At the same 2015 General Meeting, the framework for the Articles of Association of the Swatch Group proposed by the Compensation Ordinance, which is to apply to compensation and, in particular, to the decision-making process by the shareholders, will be created. The Board of Directors proposes that the General Meeting resolve on the total amounts for

- the fixed compensation of the members of the Board of Directors for the period until the next ordinary General Meeting,
- the fixed compensation of the members of the Group Management for the current year,
- the variable compensation of the executive members of the Board of Directors for the completed business year,
- the variable compensation of the members of the Group Management for the completed business year.

The Compensation Report is divided into the following sections:

- one section with information regarding the structure and decision-making processes within the Compensation Committee and the Board of Directors;
- one section with the description of the compensation system;
- one section that sets out the specific compensation in the 2014 business year.

The Compensation Report fulfils the provisions of the Ordinance against Excessive Compensation in Listed Stock Corporations, which came into force on 1 January 2014, and accordingly the provisions of the Swiss Code of Obligations. The Report essentially follows the recommendations of the Swiss Code of Best Practices for Corporate Governance issued by *economiesuisse* and the Guidelines on Corporate Governance issued by SIX Swiss Exchange Ltd.

Disclosure takes place according to the „accrual principle“. The current part of the report (Section 4a-e) was reviewed by PricewaterhouseCoopers Ltd.

1. Compensation Committee

1.1 Composition of the Compensation Committee

As the Board of Directors of the Swatch Group is intentionally kept small in number (currently 6 members), it functions at the same time as the Compensation Committee. This eliminates the need for demarcating the areas of responsibility and ensuring the flow of information.

Up until the 2014 General Meeting the Chair of the Board of Directors (Ms Nayla Hayek) also presided over the Compensation Committee.

After the 2014 General Meeting, the Board of Directors entrusted Mr Ernst Tanner with the chair of the Compensation Committee.

All members of the Board of Directors abstain from discussions and decisions regarding their compensation and from discussions and decisions regarding compensation of persons closely related to them (such as family members).

No members having any cross-involvement belong to the Compensation Committee, such that no conflicts of interest arise from this point of view as well.

1.2 Tasks / competences

The Compensation Committee handles the compensation policy of the company. It assists the Board of Directors in determining the compensation system and the principles of compensation, and in the preparation of motions to the General Meeting for approving compensation. The Compensation Committee may submit proposals and recommendations to the Board of Directors in all matters pertaining to compensation.

COMPENSATION REPORT

With the coming into force of the revised Articles of Association of the Swatch Group, the Compensation Committee will attend to all issues related to compensation, and will propose solutions for the attention of the Board of Directors. The decision-making body is the Board of Directors. The Board of Directors will submit the necessary resolutions to the General Meeting for its approval.

At the 2015 General Meeting, the General Meeting will for the first time vote on the fixed total compensation of the members of the Board of Directors until the next General Meeting and of the members of the Executive and Extended Group Management Board for the 2015 business year along with the variable compensation of the members of the Executive and Extended Group Management Board for the 2014 business year.

1.3 Meetings

The Compensation Committee met twice during the 2014 business year: once to set salaries and bonuses, a second time to set the share allocations.

2. Compensation system

2.1 General principles of compensation

The members of the Board of Directors and the Executive Management are entitled to compensation corresponding to their job function and degree of responsibility.

The company may award compensation for activities in undertakings that are directly or indirectly controlled by the company and for activities at the order of the undertaking. The compensation may be awarded by the company or by the companies that it controls.

The compensation of the non-executive members of the Board of Directors comprises only fixed compensation elements.

The compensation of executive members of the Board of Directors and the members of the Executive Management comprises fixed and variable compensation elements. The fixed compensation comprises base salary and may include additional compensation elements. The variable compensation is guided by the achievement of certain performance objectives.

The performance objectives may include personal goals, company-specific and division-specific objectives, along with key economic or market-related figures. In doing so, the function and the level of responsibility of the recipient of the variable compensation are taken into account.

At the request of the Compensation Committee, the Board of Directors sets the performance values and objectives of the variable compensation elements and their achievement.

The compensation system of the Swatch Group is in line with market conditions and based on performance. It is reviewed on an annual basis and adjusted when necessary.

2.2 Compensation elements

a) Non-executive members of the Board of Directors

The non-executive members of the Board of Directors receive fixed compensation. It is graduated according to functions.

b) Executive members of the Board of Directors, members of the Executive and Extended Group Management Board

The compensation system for the executive members of the Board of Directors and the members of the Executive and Extended Group Management Board provides for the following elements:

- a base salary;
- a lump-sum expenses payment;
- a bonus programme with variable compensation;
- a share programme with annual share allocations and a minimal guaranteed value;
- payments to the pension fund (Swatch Group Pension Fund) and to the Management Fund of the Swatch Group (in one specific case where the EKL-member is a foreign national, payment was made to the local pension fund).

2.3 Information on individual elements

2.3.1 Base salary

The base salary is usually paid out monthly in 13 equal instalments. The thirteenth instalment is paid each year in December. The degree of responsibility, the position and education are taken into account in the base salary.

2.3.2 Lump-sum expenses

The members of the Board of Directors and the Executive Group Management Board receive a lump-sum compensation for expenses in the amount of CHF 30,000.00; the members of the Extended Group Management Board receive such compensation of up to CHF 24,000.00. This lump-sum compensation payment covers representation and small expenses and has been agreed with the tax authority of the Canton of Bern. Executive members of the Board of Directors who at the same time belong to the Executive Management receive the lump-sum compensation only once.

COMPENSATION REPORT

2.3.3 Bonus programs

The executive members of the Board of Directors, of the Executive Group Management Board and of the Extended Group Management Board annually receive a variable bonus, which depends on the development of the Group and the business division entrusted to the respective person (brands, countries, functional area) as well as individual performance.

At the start of the year, a so-called „bonus potential“ is defined, which is paid out if the objectives are achieved. If the objectives are surpassed, more than 100% of the potential bonus will be paid. Where individual objectives are not achieved, a proportionate reduction will be made.

The bonus is determined and paid out at the start of the year, once the annual accounts are available. A recipient with a Swiss contract and residence in Switzerland receives an advance payment in December. This is usually 70% of the bonus potential, provided that the set objectives (turnover, operating profit) will foreseeably be achieved; if not, a payment of 50% will be made.

The assessment criteria that apply are, among other things: turnover development, development of operating profit, EBIT, changes in market share, development of inventory and receivables, accomplishment of development and set-up projects, success in negotiations, successful implementation of costreduction programmes, personnel fluctuation, and motivation of employees. The assessment criteria are individually tailored to the function holders and weighted accordingly.

For the particular promotion of the Group's interests, a part of the bonus is awarded as a Group bonus. The percentage share of the Group component varies according to function.

2.3.4 Share program

On an annual basis, a number of shares with a low exercise price are offered to the executive members of the Board of Directors and the members of the Executive Group Management Board and the Extended Group Management Board. In 2012 and 2013, this amounted to CHF 4.00. One-third of the allocation may be exercised and subscribed immediately. In one and two years respectively, an additional one-third may be exercised and subscribed. After subscription, the security may be freely disposed of. In the event of an early departure, the allocations for non-exercised options expire; upon retirement, they are immediately available.

The allocation of the share subscription rights takes place through the Board of Directors after the ordinary General Meeting. In 2015, the General Meeting for the first time will decide on the overall allocation upon a motion of the Board of Directors. A certain minimum allocation value was contractually guaranteed to the executive members of the Board of Directors and the members of the Executive Group Management Board and the Extended Group Management Board. For executive members of the Board of Directors and members of the Executive Group Management Board, this amounted to CHF 50,000.00; for members of the Extended Group Management Board, this amounted to generally CHF 25,000.00 (allocation value = share price minus CHF 4.00 exercise price).

The tax value or the daily value at the time of the allocation is used as the basis for calculation for the compensation of the allocated shares. The tax value is equal to the average price of the share during the subscription-payment period, less the exercise price. This exercise price applies for the first one-third of the allocated shares, which can be paid up from the date of allocation over a period of one month. The daily value is equal to the share price on the date of allocation, less the exercise price. This price is used for the assessment of the second and the last third of the allocated shares, which may be exercised after one or two years, respectively.

The following values apply for 2014 and 2013:

	2014	2013
Date of grant	8 July 2014	12 July 2013
Tax value	CHF 89.05	CHF 92.90
Share price on the day of allocation	CHF 95.40	CHF 94.80
Exercise price	CHF 4.00	CHF 4.00
Daily value on the date of allocation	CHF 91.40	CHF 90.80

2.3.5 Pension Fund / Management Fund

The executive members of the Board of Directors and the members of the Executive Group Management Board and of the Extended Group Management Board respectively, are insured by the Swatch Group Pension Fund and the Swatch Group Management Fund.

The Swatch Group Pension Fund insures incomes of up to CHF 320,000.00.

The Management Fund covers income components between CHF 320,000.00 and CHF 842,400.00.

The Management Fund provides for contributions of 10%. 75% of such contributions are assumed by the employer.

COMPENSATION REPORT

3. Additional contractual elements

3.1 Term and termination periods of employment contracts

All employment contracts of the Executive Group Management Board and of the Extended Group Management Board respectively, are concluded for an indefinite term.

They may be terminated by either party with a notice period of six months as per the end of a month.

3.2 Payment of salaries

Salaries are paid on a monthly basis. No advance payments are made, either for the current month or for longer periods. The same applies to compensation within the framework of mandate relationships.

3.3 Compensation upon commencement of the employment relationship

Swatch Group does not pay any compensation upon the conclusion of an employment contract or upon the start of work („golden hellos“/„golden handshakes“).

Moreover, no compensation is provided to settle share options or other financial benefits of a prior employer that were rendered void through the job change.

3.4 Loans to members of governing bodies

The Swatch Group and its subsidiaries do not grant loans to the members of its governing bodies.

However, just like all employees of the Swatch Group in Switzerland, the executive members of the Board of Directors and the members of the Executive Group Management Board and of the Extended Group Management Board respectively, have the option of taking out a mortgage loan with the Swatch Group Pension Fund to finance the purchase of real estate in Switzerland. Such a mortgage loan may be granted only for a primary residence. The applicable conditions are the same as those that apply to all employees of the Swiss Swatch Group companies (lending limit, interest rate, etc.).

3.5 Deployment in governing bodies of Group companies

It regularly occurs that executive members of the Board of Directors and members of the Executive Group Management Board and of the Extended Group Management Board respectively, must sit on governing bodies of subsidiaries, both in Switzerland and abroad (as board members, members of supervisory boards, members of advisory boards, or as managers). No additional compensation is awarded for such tasks and functions, either by the Swatch Group or by the relevant Group company.

3.6 Severance payments

The employment contracts of the members of the Executive Group Management Board or the Extended Group Management Board do not provide for severance payments or any payments whatsoever upon termination of the employment relationship.

In addition, no payments („golden parachutes“, etc.) are provided in the event of a change of control.

3.7 Mandates with former members of the Executive Group Management Board or the Extended Group Management Board

It may occur that members of the Executive Group Management Board and of the Extended Group Management Board respectively, who have resigned from their functions are employed on a mandate basis from time to time. In all such cases, clear written mandate contracts are concluded; these must be approved by the President of the Executive Group Management Board. Such mandate contracts contain the same restrictive conditions as employment contracts (contractual term, payments, etc.).

COMPENSATION REPORT

4. Compensation for the members of the Board of Directors and Group Management (KL/EKL) in 2014

This part of the report is subject to revision by PricewaterhouseCoopers Ltd

a. Board of Directors (BoD)

2014 Name	Function	Compensation for functions in the BoD ¹⁾	Compensation for executive functions				Total ⁶⁾
			Base compensation ²⁾	Bonus ³⁾	Share options ⁴⁾	Other compensation ⁵⁾	
		(CHF)	(CHF)	(CHF)	(CHF)	(CHF)	(CHF)
Nayla Hayek	Chairwoman	231 378	1 001 928	1 450 000	1 812 335	418 934	4 914 575
	Vice-						
Ernst Tanner	Chairman	166 146				8 850	174 996
Esther Grether ⁷⁾	Member	64 835				3 362	68 197
Georges Nicolas Hayek ⁸⁾	Member	157 186				7 186	164 372
Prof. Dr. h.c. Claude Nicollier	Member	155 603				8 068	163 671
Dr. Jean-Pierre Roth	Member	155 603				8 068	163 671
Total		930 751	1 001 928	1 450 000	1 812 335	454 468	5 649 482

2013 Name	Function	Compensation for functions in the BoD ¹⁾	Compensation for executive functions				Total ⁶⁾
			Base compensation ²⁾	Bonus ³⁾	Share options ⁴⁾	Other compensation ⁵⁾	
		(CHF)	(CHF)	(CHF)	(CHF)	(CHF)	(CHF)
Nayla Hayek	Chairwoman	230 316	1 001 928	1 500 000	1 829 999	407 178	4 969 421
	Vice-						
Ernst Tanner	Chairman	166 146				8 850	174 996
Esther Grether	Member	155 603				8 068	163 671
Georges Nicolas Hayek ⁸⁾	Member	156 516				7 186	163 702
Prof. Dr. h.c. Claude Nicollier	Member	155 603				8 068	163 671
Dr. Jean-Pierre Roth	Member	155 603				8 068	163 671
Total		1 019 787	1 001 928	1 500 000	1 829 999	447 418	5 799 132

1) Total annual compensation allocated on a cash or accrual basis, not including any reimbursement for travel and other business expenses incurred. The compensation contains an amount of CHF 20,000 for functions in the Compensation Committee and the Audit Committee as well as lump-sum expense payments in the amount of CHF 30,000 per year.

2) Total annual compensation allocated on a cash or accrual basis, not including any reimbursement for travel and other business expenses incurred.

3) Bonus payments allocated on a cash or accrual basis.

4) The allocation and valuation of share options takes place in accordance with the conditions described in Section 2.3.4. In 2014 and in 2013, Mrs N. Hayek was allocated 20,000 share options.

5) Other compensation includes pension benefits in the amount of CHF 63,424 (2013: 63,156). Furthermore, in connection with the preparation of the Compensation Report, the remaining social benefits (employer's contributions) were specifically integrated, retroactively from 2013, in the itemisation of the compensation for the Board of Directors. For the reporting year, these amounted to CHF 391,044 (2013: CHF 384,262).

6) All amounts are gross amounts (i.e., before deduction of the social insurance contributions to be taken on by the employee).

7) BoD member until May 2014.

8) The compensation for the executive functions is set forth in paragraph b of this chapter.

COMPENSATION REPORT

b. Executive Group Management Board (KL) and Extended Group Management Board (EKL)

2014

Name	Base compensation ¹⁾ (CHF)	Bonus ²⁾ (CHF)	Share options ³⁾ (number)	Share options ³⁾ (CHF)	Other compensation ⁴⁾ (CHF)	Total ⁵⁾ (CHF)
Georges Nicolas Hayek (MB President / CEO)	1 501 925	3 170 000	24 000	2 174 800	610 320	7 457 045
Total other members	6 039 698	13 453 993	127 300	11 535 518	3 654 367	34 683 576
Total	7 541 623	16 623 993	151 300	13 710 318	4 264 687	42 140 621

2013

Name	Base compensation ¹⁾ (CHF)	Bonus ²⁾ (CHF)	Share options ³⁾ (number)	Share options ³⁾ (CHF)	Other compensation ⁴⁾ (CHF)	Total ⁵⁾ (CHF)
Georges Nicolas Hayek (MB President / CEO)	1 501 925	3 220 000	24 000	2 196 000	586 662	7 504 587
Total other members	6 085 953	14 238 057	126 300	11 556 433	3 784 143	35 664 586
Total	7 587 878	17 458 057	150 300	13 752 433	4 370 805	43 169 173

1) Total annual base compensation allocated on a cash or accrual basis, including lump-sum expense payments but not including any reimbursement for travel and other business expenses incurred.

2) Variable bonus payments allocated on a cash or accrual basis.

3) The allocation and valuation of share options takes place in accordance with the conditions described in Section 2.3.4.

4) Other compensation includes pension benefits in the amount of CHF 624,557 (2013: 683,201). Furthermore, in connection with the preparation of the Compensation Report, the remaining social benefits (employer's contributions) were specifically integrated, retroactively from 2013, in the itemisation of the compensation for the KL and EKL. For the reporting year, these amounted to CHF 3,511,582 (2013: CHF 3,563,164). Other compensation also includes further benefits in the amount of CHF 128,548 (2013: CHF 124,440).

5) All amounts are gross amounts (i.e., before deduction of the social insurance contributions to be taken on by the employee).

The figures presented include all direct and indirect compensation.

Mr G.N. Hayek, as the CEO, received the highest compensation.

No compensation payments whatsoever were distributed to former members of the Board of Directors and of the Group Management Board respectively, in connection with prior activities as members of the governing bodies of the company.

c. Loans and credits to the Board of Directors and the Group Management

In the 2014 business year, no loans or credits were granted to members of the Board of Directors, the Executive Group Management Board or the Extended Group Management Board respectively. Moreover, no loans or credits were granted to former members of the Board of Directors, the Executive Group Management Board or the Extended Group Management Board respectively.

At the end of 2014, there were no credit or loans to (current or former) executive members of the Board of Directors or the Group Management Board.

d. Compensation, loans, and credits to closely related persons

In the 2014 business year, no non-market-based compensation was awarded to persons who are closely related to the members of the Board of Directors, the Executive Group Management Board or the Extended Group Management Board respectively.

e. Impermissible compensation

In the 2014 business year, the company did not award any severance payments to the members of the Board of Directors, the Executive Group Management Board or the Extended Group Management Board respectively.

Likewise, in the 2014 business year, no compensation was paid in advance to members of the Board of Directors, the Executive Group Management Board or the Extended Group Management Board respectively.

REPORT OF THE STATUTORY AUDITOR TO THE GENERAL MEETING OF THE SWATCH GROUP LTD, NEUCHÂTEL

We have audited the content of sections 4a-e of the Compensation Report dated 20 February 2015 of The Swatch Group Ltd for the year ended 31 December 2014.

Board of Directors' responsibility

The Board of Directors is responsible for the preparation and overall fair presentation of the Compensation Report in accordance with Swiss law and the Ordinance against Excessive Compensation in Stock Exchange Listed Companies (Ordinance). The Board of Directors is also responsible for designing the remuneration system and defining individual remuneration packages.

Auditor's responsibility

Our responsibility is to express an opinion on the accompanying Compensation Report. We conducted our audit in accordance with Swiss Auditing Standards. Those standards require that we comply with ethical requirements and plan and perform the audit to obtain reasonable assurance about whether the remuneration report complies with Swiss law and articles 14–16 of the Ordinance.

An audit involves performing procedures to obtain audit evidence on the disclosures made in the Compensation Report with regard to compensation, loans and credits in accordance with articles 14–16 of the Ordinance. The procedures selected depend on the auditor's judgment, including the assessment of the risks of material misstatements in the remuneration report, whether due to fraud or error. This audit also includes evaluating the reasonableness of the methods applied to value components of remuneration, as well as assessing the overall presentation of the Compensation Report.

We believe that the audit evidence we have obtained is sufficient and appropriate to provide a basis for our opinion.

Opinion

In our opinion, the Compensation Report of The Swatch Group Ltd for the year ended 31 December 2014 complies with Swiss law and articles 14–16 of the Ordinance.

PricewaterhouseCoopers AG

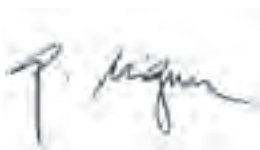

Gerhard Siegrist
Audit expert
Auditor in charge



Roy Bächinger
Audit expert

Basel, 20 February 2015







The Swatch Group Ltd

P.O. Box, Seedorfstrasse 6, CH-2501 Biel/Bienne, Switzerland

Phone: +41 32 343 68 11, Fax: +41 32 343 69 11

E-mail: www.swatchgroup.com/contactus

Internet: www.swatchgroup.com